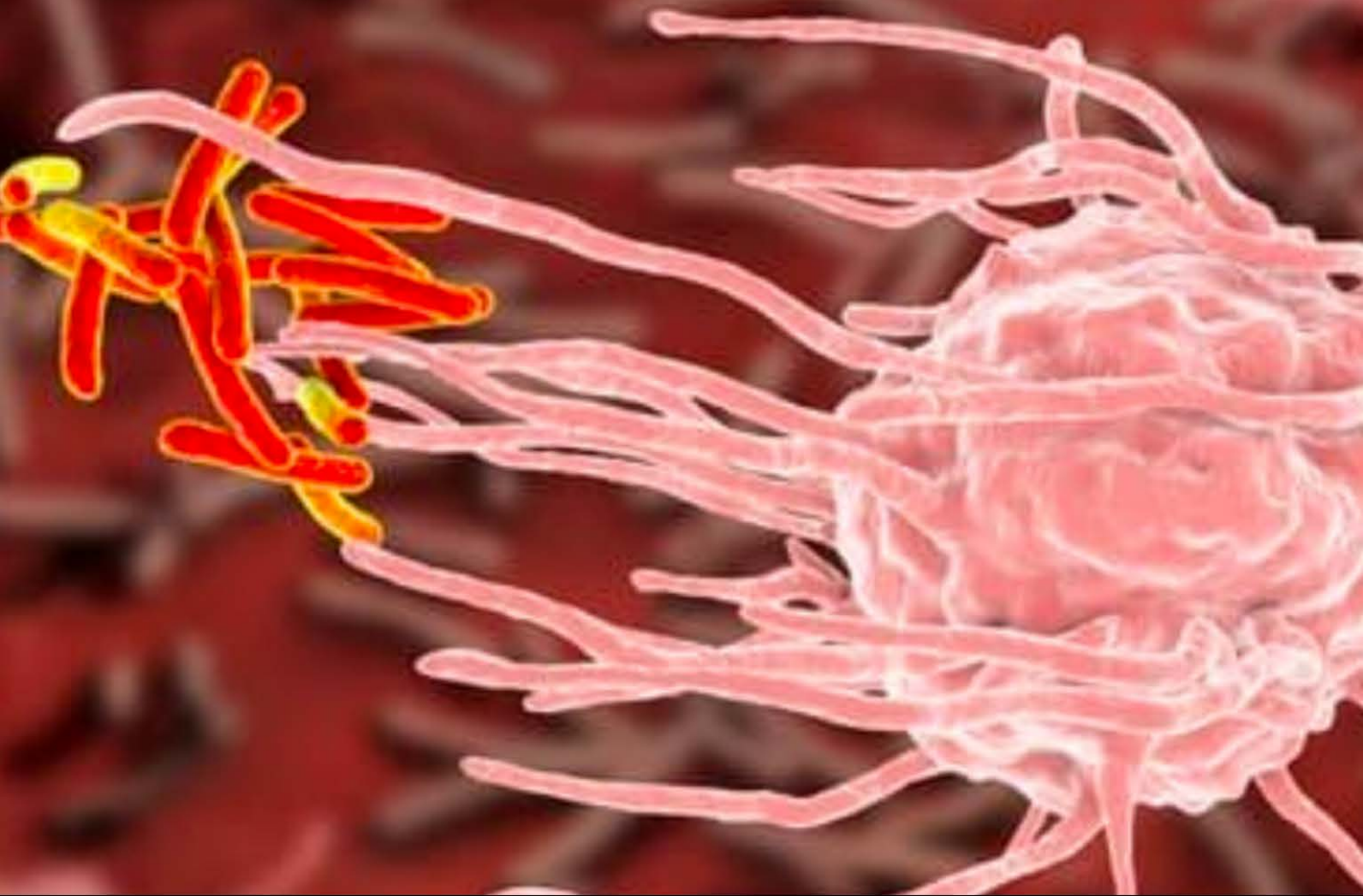


IMMUNOLOGY AND RHEUMATOLOGY

NOTES

PRE-SUMMARIZED
READY-TO-STUDY
HIGH-YIELD NOTES

FOR THE TIME-POOR
MEDICAL, PRE-MED,
USMLE OR PA STUDENT



MEDICAL NOTES

(MBBS, MD, MBChB, USMLE, PA, & Nursing)

Anatomy, Physiology, Pathophysiology, Pathology, Histology & Treatments

www.regentstudies.com/medicalnotesmbbs

Table Of Contents:

What's included: Ready-to-study anatomy, physiology and pathology notes of the immune system presented in succinct, intuitive and richly illustrated downloadable PDF documents. Once downloaded, you may choose to either print and bind them, or make annotations digitally on your iPad or tablet PC.

Free bonus: 'Rheumatology' chapter of Toronto Notes for reference and further detailed reading.

File List:

- The Immune Systems Basics
- The Immune System In Detail
- Reproductive Immunology
- Transplants
- Inflammation
- Anti-Rheumatoid Drugs
- Autoimmunity
- Polymyalgia Rheumatica
- Rheumatic Fever
- Rheumatoid Arthritis
- Huntingtons Disease
- Hypersensitivities
- Immunodeficiency
- Infection Immunology
- Lupus
- Pathogens & Immunity
- Psychoneuroimmunology
- TORONTO - Rheumatology

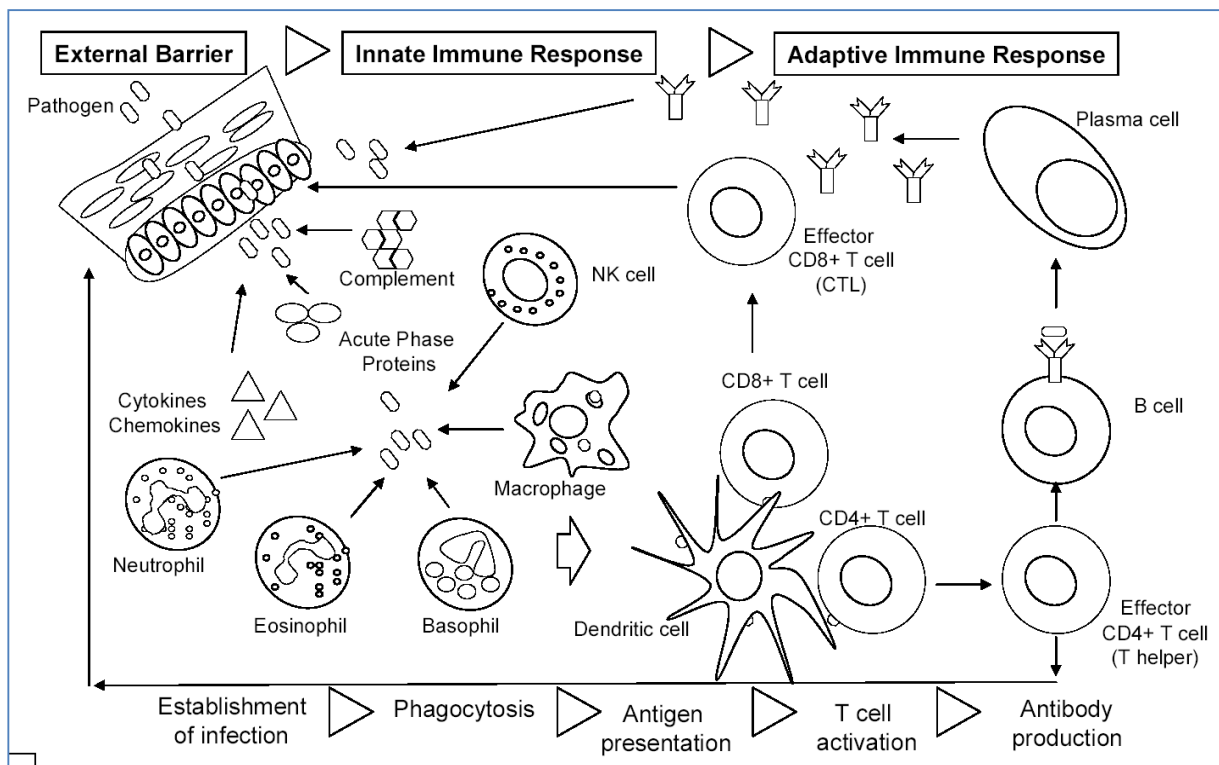
The Immune System – At A Glance

The Immune System:

- The immune system is more a **functional system** rather than an **anatomical or organ-based** system.
- Consists of:
 - o a diverse array of molecules
 - o -and trillions of immune cells (especially lymphocytes).
 - These molecules & immune cells inhabit lymphoid tissues & circulate in body fluids.
- Functions to protect the body from:
 - o Most infectious microorganisms
 - o Cancer cells
 - o Transplanted organs
 - o Grafts
 - o Any other foreign material
- Can act directly – by cell attack
- Can act indirectly – by releasing mobilising chemicals & antibody molecules.

Terminology:

- **Pathogen:** microorganism that is able to cause disease
- **Pathogenicity:** the ability of a microorganism to cause disease.
- **Virulence:** the degree of pathogenicity.
- **Opportunistic pathogens:** bacteria which cause disease in a compromised host.
- **Normal flora:** harmless bacteria consistently associated with the host.
- **Infection:** when an organism (incl. Normal flora) breaches a body surface.
 - o Doesn't necessarily lead to disease
 - Depends on:
 - Route of entry
 - Number of pathogens
 - Immune status of host



Defence Systems of the Body:

- **Innate (non-specific) Immune System:**

- "the body's foot-soldiers"
- Already in place at birth.
- Is always prepared
- Responds within minutes
- Protects the body from all foreign substances.
- Are often sufficient to ward off invading pathogens single-handedly.
- Essentially, it reduces the workload of the adaptive system.
- The body's first 2 lines of defence.

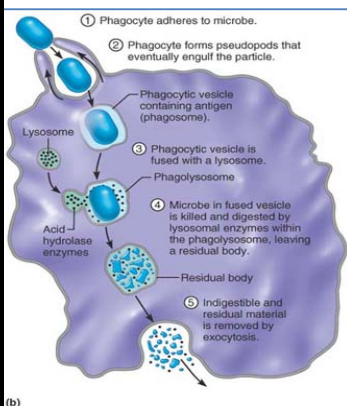
- **1st Line of Defence: Surface Barriers:**

- **Prevents Entry of Pathogen**

- Skin
 - Stratified
 - Heavily keratinised
- Mucous membranes
 - Lysozyme: enzyme found in saliva & tears → destroy bacteria.
 - Sticky Mucus: in digestive & respiratory tracts → traps bacteria.
 - Cilia – nasal & respiratory → sweep bacteria into mouth → swallowed.
 - Acid secretion: skin, vagina, stomach → kills microbes.

- **2nd Line of Defence: Internal Defenses:**

- **Prevents Spread of Pathogen If Surface Barriers are Breached**



- **Phagocytes**

- **Macrophages** – Large phagocytic cells

- **Granulocytes** – possess cytoplasmic granules

- **Neutrophils** – they release toxic chemicals into the extracellular fluid, killing both the target and themselves. (kamikaze)
- **Eosinophils** – another type of white blood cell – **kill parasitic worms.**
- **Basophils** – important in allergic reactions

- **Fever**

- When exposed to foreigners, leukocytes & macrophages secrete pyrogens → increases the body's thermostat.
- Increases metabolic rate, kills microbes, speeds up repair.

- **Natural Killer cells**

- Police the body in blood & lymph
- Can lyse & kill cancer cells & virus-infected cells
- Target all cells that lack 'self' surface receptors (non-specific)
- Kill by latching onto invaders and inducing apoptosis.
- Also secrete potent chemicals that promote inflammation

- **Antimicrobial proteins**

- Either attack microbes directly or reduce their reproductive ability.
- –'Interferons' & 'complement'

- **Inflammation**

- In response to physical trauma/intense heat/bad chemicals/infection.
- Prevents spread of damaging agents to nearby tissue
- Disposes of cell debris & pathogens
- Sets stage for repair.
- Characterised by **heat, redness, pain & swelling**

- **Adaptive (specific) Immune System:**

- “The body’s elite special forces” – equipped with high-tech weapons.
- Adaptive responses are called into action as ‘reinforcements’
- Takes much more time to mobilise than the innate response.
- Attack specific foreign substances – incl. Antigens and abnormal body cells
- When disabled → cancer, AIDS, etc.
- Tremendously amplifies the inflammatory response.
- >It is **Specific**: recognises *particular* pathogens/antigens
- >It is **Systemic**: immunity isn’t restricted to initial infection site
- >It has **Memory**: mounts stronger attacks on previously encountered pathogens.

- **The body’s 3rd line of defence**

- **Humoral Immunity** (aka. Antibody-mediated immunity)

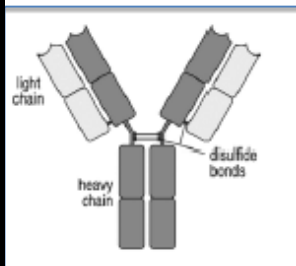
-Immunity can be **transferred** from person-person **via serum**

- **B Cells (B-Lymphocytes)**

- **Make antibodies** against soluble antigens.

- **Antibodies (Immunoglobulins):**

- Circulate freely in blood & lymph
- **Neutralises** bacteria/toxins/& viruses → marks for destruction by phagocytes or compliment.



- **Cellular Immunity**

-Immunity can be **transferred** from person-person **via blood cells**

- Antigen **causes activation of** macrophages, NK-cells, T-lymphocytes & cytokines

- Macrophages & NK-Cells – destroy intracellular pathogens
- **T Cells (T-Lymphocytes)** – induce apoptosis of body cells with viruses/intracellular bacteria/cancerous traits.
- Cytokines are secreted – enhance inflammatory response and/or activate other lymphocytes/macrophages.

- Activated cells **destroy** infected/foreign cells.

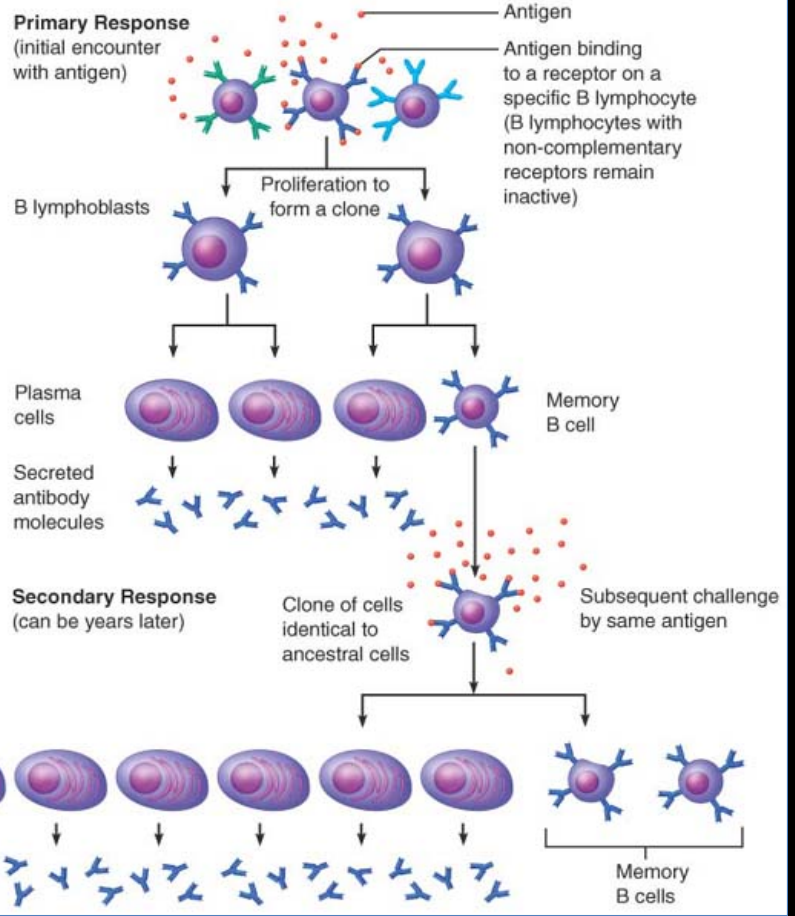
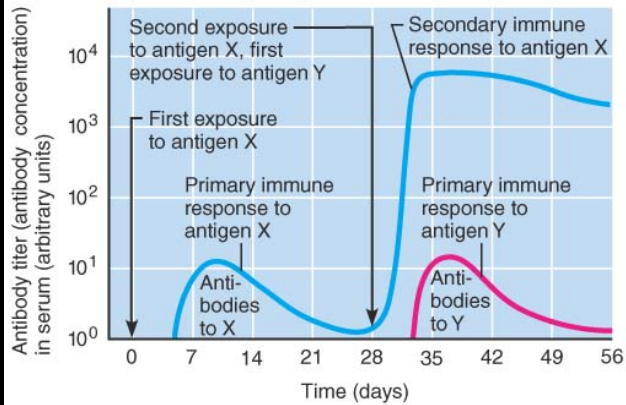
Summary

INNATE Vs ADAPTIVE IMMUNITY		
	Innate	Adaptive
Barriers	skin, epithelia, chemicals	epithelial L ϕ , Ab secretion
Proteins	complement system	antibodies
Cells	phagocytes and NK cells	lymphocytes
Specificity	shared structures of microbes	antigens
Diversity	low	very high
Memory	nil	+
Tolerance	+	+

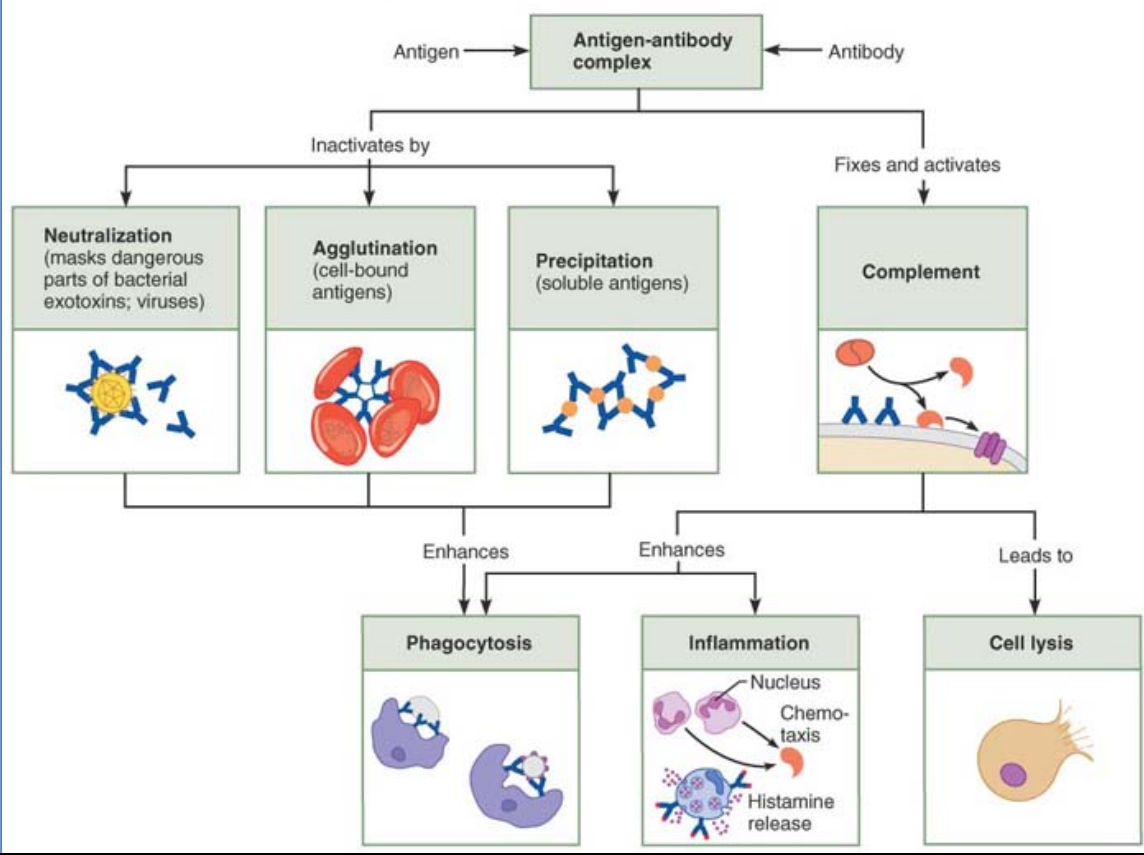
Humoral Immunity

Adaptive defenses → Humoral immunity

Adaptive defenses → Humoral immunity

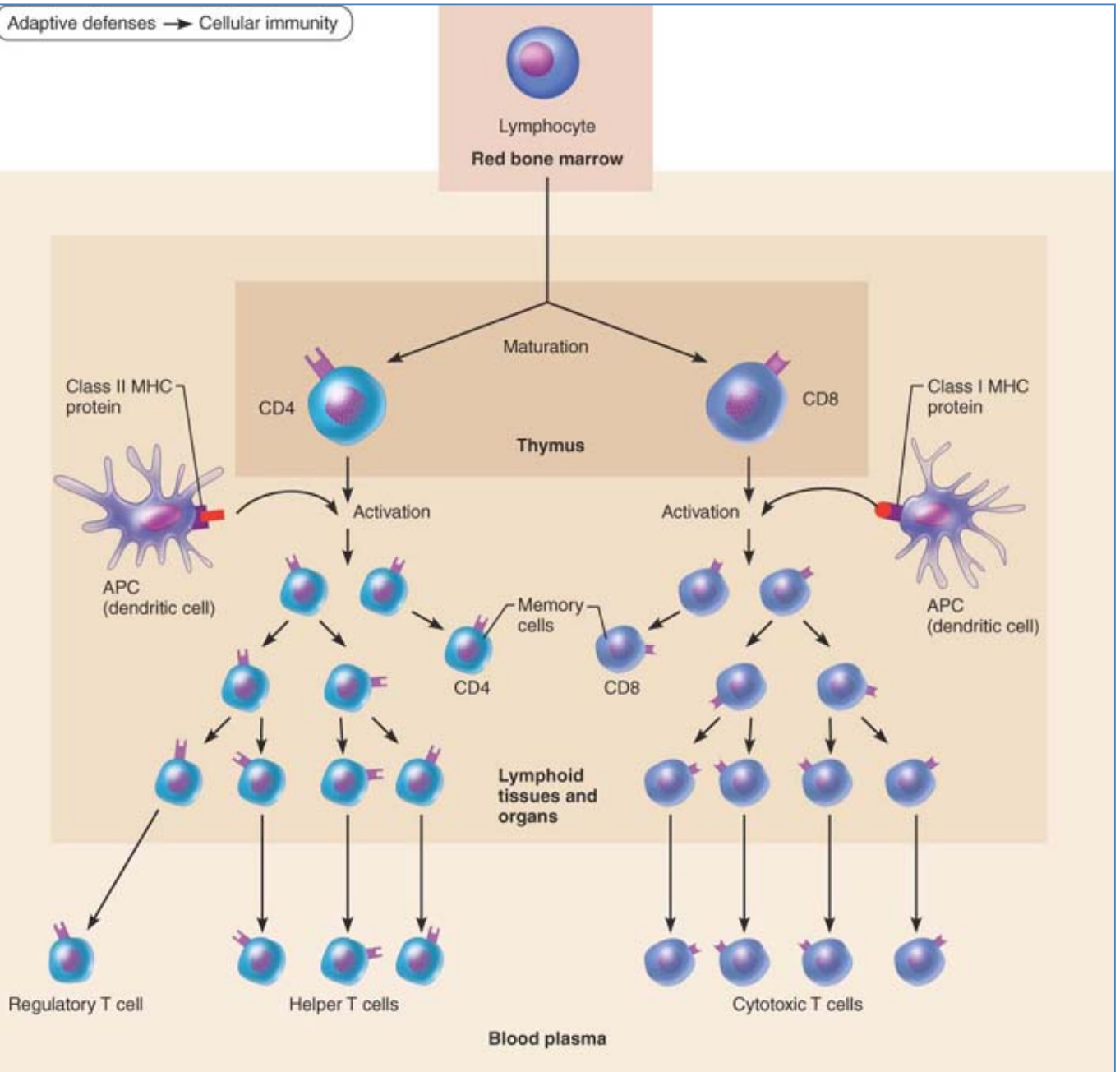


Adaptive defenses → Humoral immunity

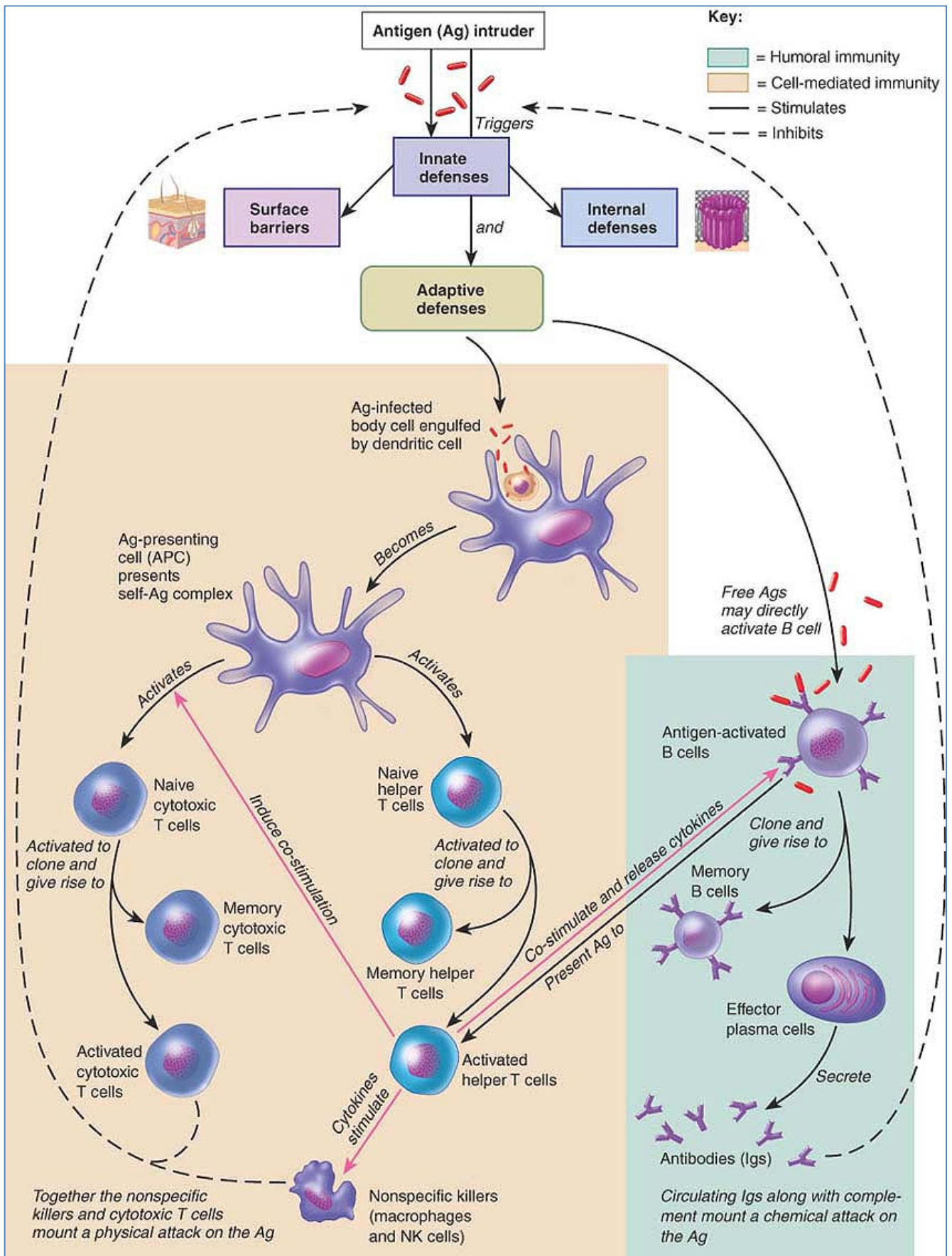


Cellular Immunity:

Adaptive defenses → Cellular immunity

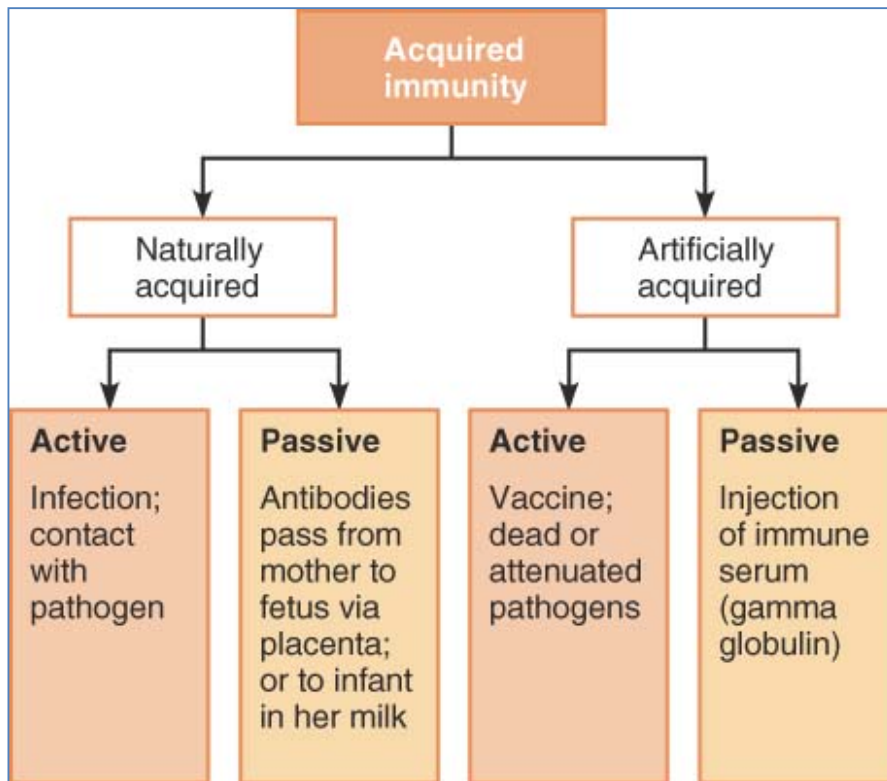


The Whole Immune System Summary:



- **Vaccination**

- **Whole organism vaccines**
 - Effective against complex pathogens (viruses & bacteria)
- **Live Attenuated vaccines**
 - Live organisms that have been de-pathogenised
- **Inactivated/killed vaccines**
 - Dead organisms containing relevant proteins but unable to replicate
- **Recombinant vaccines**
 - Artificially synthesised non-toxic antigens.



ANTIBODY RESPONSE

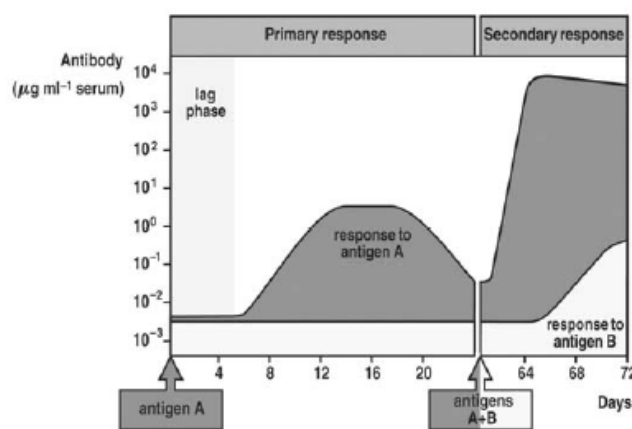


Figure 1-26 Immunobiology, 6/e. © Garland Science 2005

An antigen can be defined as a compound which when administered can provoke an immune response

After a lag period there is an antibody response which will decline with time

Following a second dose of antigen there is a shorter lag period, a larger immune response and the antibody persist for a longer period

Antibody responses are specific to a particular antigen

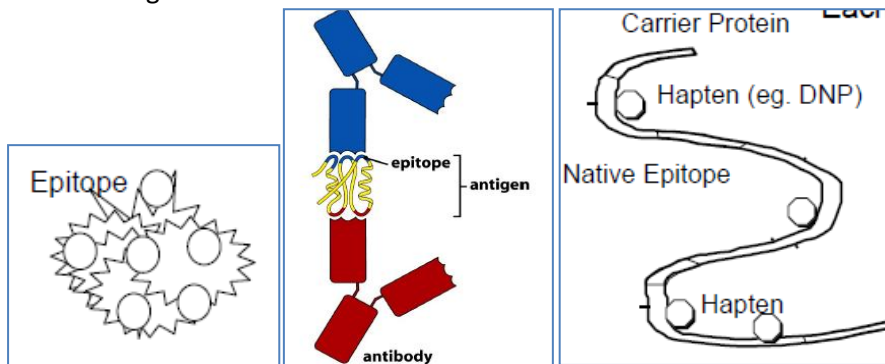
Humoral immunity can be transferred using serum

Concepts Behind the Innate & Adaptive Immune Responses

The Immune System Basics:

Antigen:

- = Any molecule that can bind specifically to an Antibody (incl. BCRs) OR T-Cell Receptor.
- Their name arises from their **Antibody-Generating** ability.
 - o However some antigens don't cause antibody production; i.e. Self-Antigens
 - o Antigens that DO induce antibody production are called **Immunogens**.
- **Antigenicity:** The degree to which an Antigen binds to Antibodies (incl. BCRs) &/or TCRs.
 - o **Antigenicity Increases with:**
 - ↑Ag. Size
 - ↑Ag. Complexity
 - ↑Ag. Foreignness
 - ↑Route of Ag. Administration (→ dealt with by different 2° Lymphoid Organs)
 - ↑Ag. Dose
- **"Epitopes":** A single Ag. can have multiple *Sites* (or Epitopes) which are Immunogenic.
- **"Haptens":** Small, Incomplete antigens that are incapable of causing an immune response by themselves, but can when attached to larger Carrier Molecules such as a Protein.



- **"Thymus-Dependent Antigens":**
 - o Antigens recognised by **B-Cells** which require Ag-Specific CD4-Helper-T-Cell help in order to Activate the B-Cell → Plasma Cell → Secrete Antibodies.
- **"Thymus-Independent Antigens":**
 - o Antigens recognised by **B-Cells** which, *by themselves*, are enough to cause B-Cell Activation (& subsequent Ab-secretion) *Without CD4-Helper-T-Cell* Assistance.
- **"Superantigens":**
 - o Bacterial or Viral Antigens that *Non-Specifically* activate T-Cells *Without being Processed by APCs*.
 - o T-Cell responses are therefore *also Non-Specific* & hence are *Maladaptive* for host & helpful to pathogen. (See section on MHC for details)
- **Common Antigens:**
 - o **Bacterial Antigens:**
 - (See Pathogen-Associated Molecular Patterns - PAMPs)
 - Flagellin
 - Capsule
 - Cell Wall
 - Bacterial Toxins (Endotoxins & Exotoxins)
 - o **Viral Antigens:**
 - (See Pathogen-Associated Molecular Patterns - PAMPs)
 - Capsid Proteins
 - Nucleoproteins
 - Envelope Glycoproteins
 - o **Self-Cell Surface Antigens:**
 - Red Blood Cell Antigens (A, B, Rhesus-D)
 - Major-Histocompatibility Complex Antigens (MHC-I & -II)
 - Clusters of Differentiation (CD) – Cell surface antigens. (Eg. CD40/CD28 etc)

Antibody:

- = Class of proteins called Immunoglobulins that Directly Bind to Specific Antigen.
- They are produced by Plasma Cells (Activated B-Cells) in response to infection/immunisation.
- **4 Functions:**
 - They bind specifically to their corresponding antigens, leading to:
 - **1. Neutralisation** of Pathogens/Toxins → Phagocytosed.
 - **2. Opsonisation** of Pathogen → Marks them for destruction by Phagocytes.
 - **3. Activation of Complement** → Lysis of Extracellular Bacteria → Phagocytosed.
 - **4. Ab-Dependent Cellular Cytotoxicity (ADCC)** → Lysis of a Target Cell that has been bound by Specific Antibodies.
 - **NK-Cells** → Lysis of a Pathogen-Infected Cell.
 - **Eosinophils (Via IgE)** → Kills Parasites that are too big for phagocytosis.

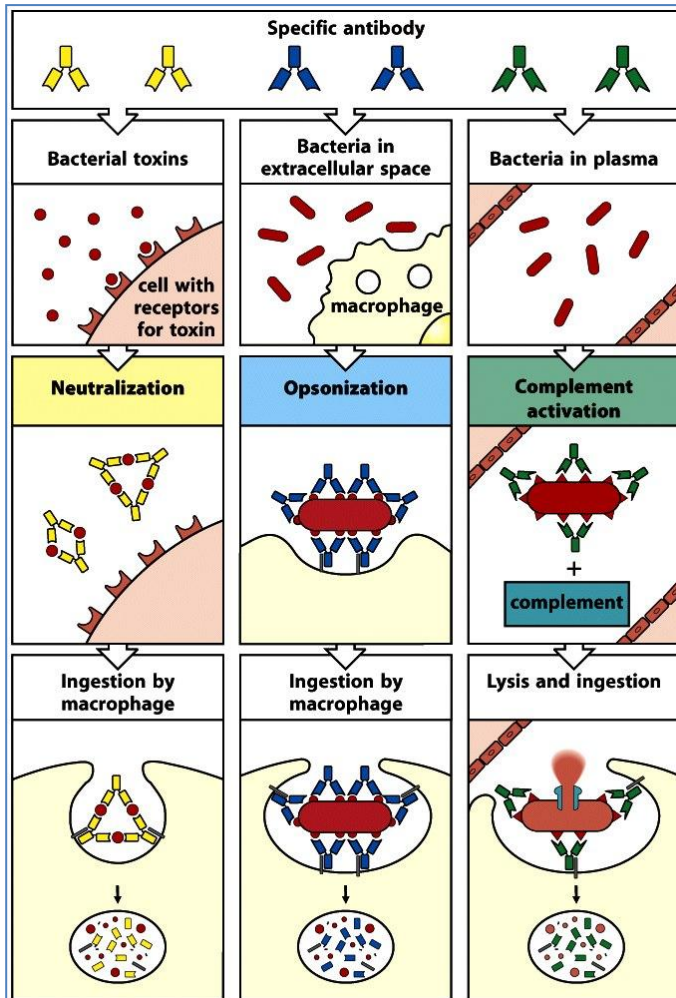
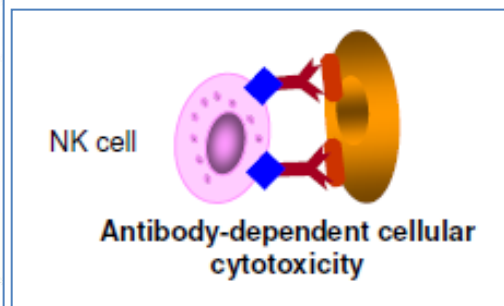
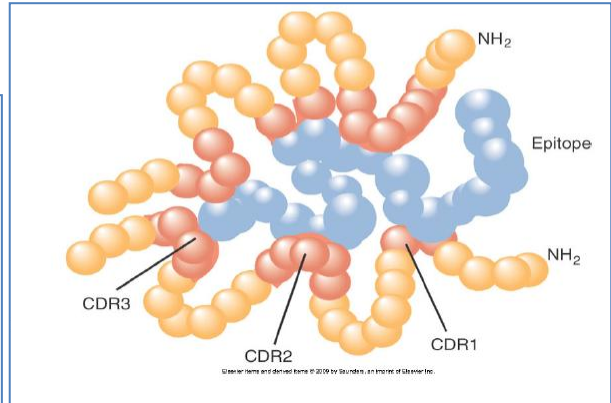
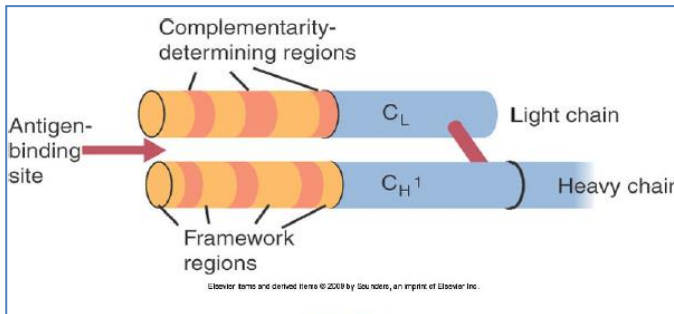


Figure 1-26 Immunobiology, 7ed. (© Garland Science 2008)

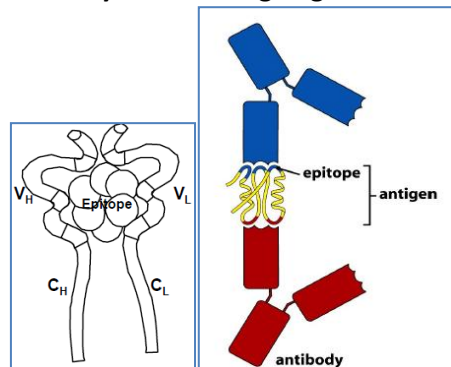


- **Where Are They Found?**
 - On their own (in plasma)
 - As Antigen-Receptors on B-Cells (BCRs).
- **Structure:**
 - **Y-Shaped molecule:**
 - Arms = Antigen Binding Sites
 - Tail = Constant Region
 - **2x Heavy (Long) Chains & 2x Light (Short) Chains:**
 - Each chain has a **Constant Region** & a **Variable Region**.
 - **Constant Region:**
 - Interacts with Effector Cells, Fc-Receptors (On NK-Cells; in ADCC) & Complement.
 - Constant Regions of BCRs & TCRs are involved in Signal Transduction into B/T-Cell.
 - **Variable Region:**
 - Binds to the Ag
 - Highly Variable

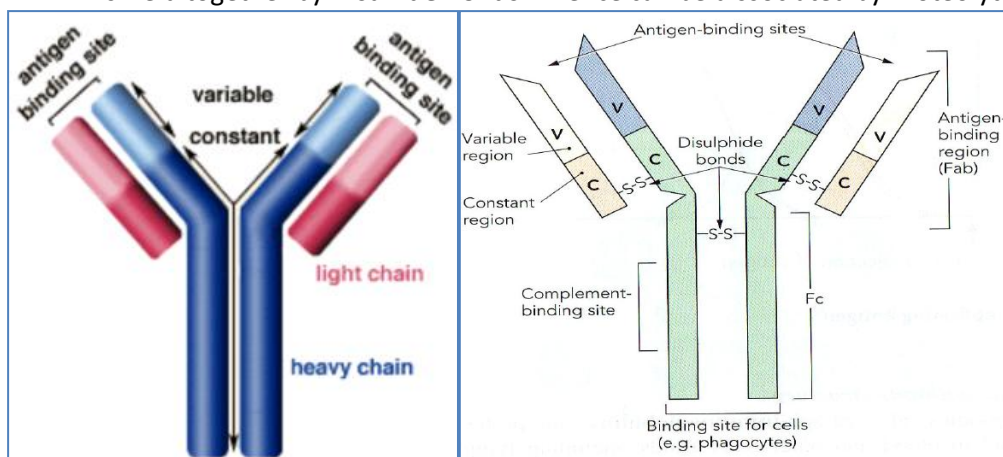
- **Antigen Binding Sites** (Same for BCRs):
 - = the Variable Regions of partnered Heavy & Light Chains (V_H & V_L).
 - Within these Variable Regions are Ag-Specific **Complementarity-Determining Regions (CDRs)**.
 - These CDRs allow binding of **Intact Antigen** by adhering to epitopes on the outside of folded antigenic proteins. (See diagram)
 - **NB: Typically, Ag's bind to Ab's via Non-Covalent Forces**, rather than chemically binding:
 - I.e. Electrostatic Forces,
 - Hydrogen Bonding,
 - Van-der-Waal's Forces,
 - Hydrophobic Forces.



- **Nomenclature:**
 - F_{ab} = Antigen Binding Site
 - F_c = Constant Region
 - V_H = Variable Region of a Heavy Chain
 - V_L = Variable Region of a Light Chain
 - C_H = Constant Region of a Heavy Chain
 - C_L = Constant Region of a Light Chain
 - CDR = Complementarity Determining Region

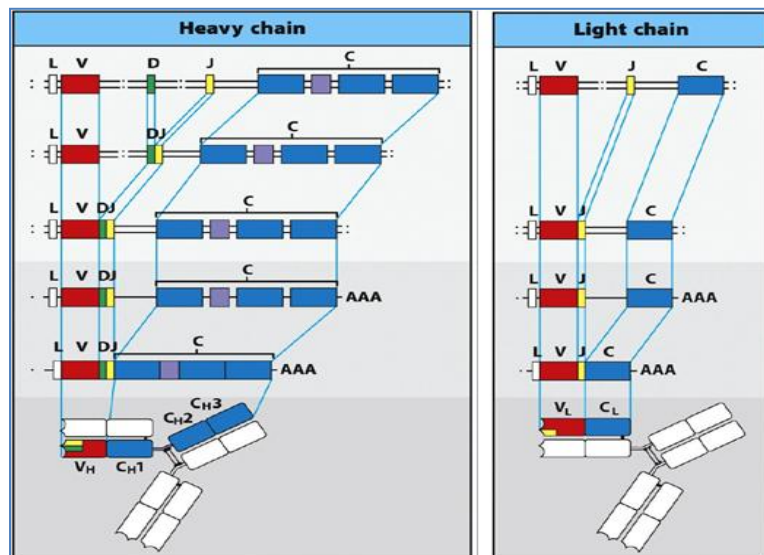


- **Hinge Region:**
 - Formed by the Heavy Chains
 - Allows flexible binding of Antigen & Enables Cross-Linking between Multiple Ab's & Ag's.
 - Is Held together by **Disulfide Bonds** – Hence can be dissociated by Proteolytic Cleavage.



- **Generating Diversity of Antibody-Repertoire:**

- **Why?**
 - Since Antibodies & Ab-based receptors (in this case BCRs & also the F_{ab} on TCRs) are the only *Activators & Effectors* of the Adaptive Immune System, they have to be able to *Evolve* to keep up with *Evolving Pathogens*.
- **How?**
 - **Primary Diversification Mechanisms (During B/T-Cell Maturation In 1° Lymphoid Organs):**
 - **Ig-Gene Rearrangement (B-Cells):**
 - **1. Heavy Chain Rearrangement:**
 - Random selection of 1xGene from Each of the **V, D & J** –Gene Loci, Then Recombination of these to make a functional gene.
 - **2. Light Chain Rearrangement:**
 - Random selection of 1xGene from Each of the **V & J** –Gene Loci, Then Recombination of these to make a functional gene.
 - NB: Very similar to TCR-Gene Rearrangement (T-Cells).
 - **NB: Important Enzymes Involved:**
 - **RAG-1 Recombinase**
 - **RAG-2 Recombinase**
 - **Ligases**



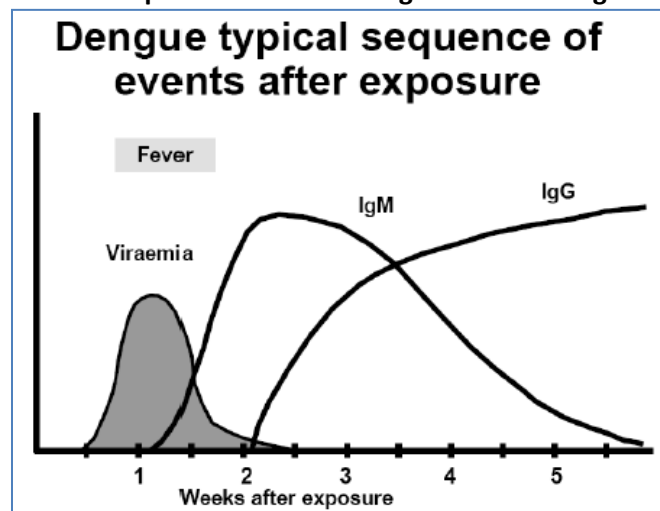
▪ **Secondary Diversification Mechanisms [B-Cells Only] (In 2° Lymphoid Organs):**

- **Somatic Hypermutation:**
 - Occurs in Activated B-Cells in Germinal Centres.
 - – Single Amino-Acid Mutations are introduced into Variable-Region-Genes.
 - Result = Activated B-Cells with Increased *AND* Decreased Ag-Affinity.
 - **New Ag-Receptors (BCRs) are tested for Increased Affinity:**
 - Cells with Receptor Mutations that Decrease Ag-Affinity → Die.
 - Cells with Receptor Mutations that Increase Ag-Affinity → Survive.
 - →→ **Proliferation of High-Affinity B-Cells.**
 - →→ **↑ Ab Affinity**
- **Isotype Switching:**
 - Occurs in Activated B-Cells in Germinal Centres.
 - – F_C Region-Genes of IgM are Replaced with F_C Region-Genes for IgG/IgA/IgE.
 - **Requires $T_{H1/2}$ -Cell Help:**
 - **NB:** Cytokines from $CD4-T_H$ -Cells determine which Ab-Class is made.
 - **NB:** It is triggered at the time of B-Cell Activation & hence also Requires $CD40_{(B-Cell)}:CD40L_{(T-Cell)}$ Interaction
 - This change in Ab Constant-Regions → Change in Ab Effector Function.
 - See Below For Details:

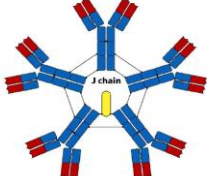
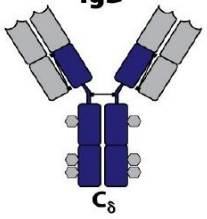
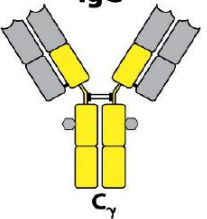
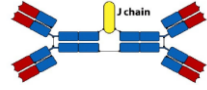
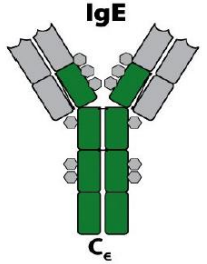
- 'Isotype Switching':

- **IgM & IgD are the *Default Abs*** Expressed on Naive B-Cells (as BCRs)
- **IgM** is the 1st Ab-Isotype to be secreted by B-Cells (Plasma Cells)
- However, IgM has limited versatility & therefore the body requires different Isotypes of that same Antibody for different effector functions.
- **Activated B-Cells (Plasma Cells) Undergo *Class-Switching* → Secrete:**
 - **IgG_{1/2/3/4}**
 - **IgA**
 - **IgE**
- **Trigger – Isotype Switching Requires CD4-T-Cell Help:**
 - Activated (Ag-Specific) CD4-Helper-T-Cells, (Pre-differentiated due to Ag-Presentation), Recognise & Bind to Ag:MHC-II Complexes on Activated B-Cells → Secrete **Cytokines**:
 - **NB: T_H-Cell Binding Requires CD40_(B-Cell):CD40L_(T-Cell) Interaction**
 - **If the Ag was a *Thymus Dependent Antigen* →**
 - T_H-Cell → Activates the B-Cell → Differentiate/Proliferate → Plasma Cells → Secrete Antibodies (Ab Isotypes depend on Cytokine Combination).
 - **If the Ag was a *Thymus Independent Antigen* →**
 - B-Cell is already activated; T-Cell Cytokines cause B-Cell to → **Isotype Switching** from the IgM (default) to other classes. (IgG/IgA/IgE)
 - **NB: Cytokines from CD4-T_H-Cells determine which Ab-Class is made.**
 - **NB: Ab Specificity doesn't change.**
- **Mechanism Behind Isotype Switching:**
 - Genes encoding the *Constant Regions* of the IgM *Heavy Chains* undergo Recombination → Replaced with Heavy-Chain Constant-Region Genes for IgG/IgA/IgE.
 - This change in Ab Constant-Regions → Change in Functional Specialisation of the Ab.

Example of Timeframe of Ig-Class Switching



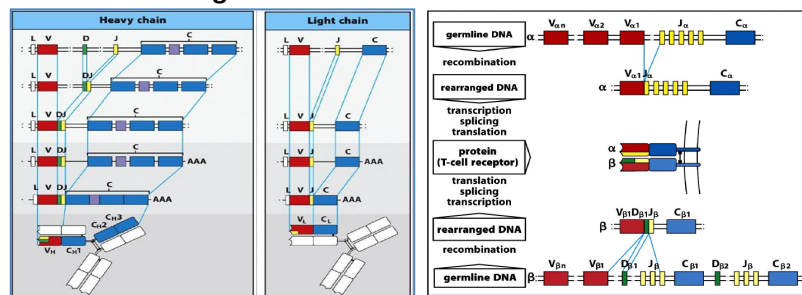
- The 5 Isotypes:

Isotype	Functional Specialisation	Morphology	Picture
IgM	<p>- 1st Ab Produced in a Primary Humoral Response.</p> <ul style="list-style-type: none"> - Neutralisation - Opsonisation of Bacteria - Activates Complement Cascade <p>- Act as B-Cell Ag-Receptors (BCRs). - (Serum $T_{1/2}$ = 10 Days)</p>	<p>- Pentamer (5 Monomers) (Massive Molecule → Relatively Cumbersome) - (NB: Monomeric on B-Cells)</p>	
IgD	<p>- Act as B-Cell Ag-Receptors (BCRs). - (Serum $T_{1/2}$ = 3 Days)</p>	- Monomer	
IgG	<p>- The Major Serum Ab-Isotype. - The 2nd Ab produced in Humoral Response. - Responsible for most Ab Reactions.</p> <ul style="list-style-type: none"> - Neutralisation - #1 - Opsonisation of Bacteria - Activates Complement Cascade <p>- The ONLY Isotype in PLACENTAL TRANSFER. - Also DIFFUSES into EXTRAVASCULAR SITES. - 4 Sub-Classes (IgG1, IgG2, IgG3, IgG4) - (Serum $T_{1/2}$ = 7-21 Days; depending on Sub-Classes)</p>	- Monomer	
IgA	<p>- The Major Ab in Mucosal Immunity (Secretions)</p> <ul style="list-style-type: none"> - Saliva - Tears - GIT - Bile - Colostrum/Breast Milk - Respiratory Tract - Urinary Tract <p>Functions:</p> <ul style="list-style-type: none"> - Neutralisation - Opsonisation of Bacteria <p>- Transported Across Epithelium - Also DIFFUSES into EXTRAVASCULAR SITES. - Very Little Found in Plasma. - ($T_{1/2}$ = 6 Days)</p>	<p>- Dimer (In Secretions) - Monomer OR Dimer (In Serum)</p>	
IgE	<p>- Major Ab in Allergic Reactions & Inflammation. - Major Ab in Parasitic Infection. - Very Little Found in Plasma. - F_C-Region binds to Mast Cells → Allergy:</p> <ul style="list-style-type: none"> - Histamine Release - Serotonin Release - Other Vasoactive Amines <p>- (Serum $T_{1/2}$ = 2 Days)</p>	- Monomer	

NB: IgM & IgE both have 1x Extra Constant Domain (3 instead of 2)

Antigen Receptors (on B & T-Lymphocytes):

- Lymphocytes become *Immunocompetent* BEFORE meeting their antigens. (I.e. They are equipped with their specific Antigen-Receptors before leaving the Primary Lymphoid Organs – Thymus/Bone-Marrow)
- **Hence, Antigen Receptors on Lymphocytes are pre-determined by Genetics, not antigens.**
 - o The Presence of an Antigen just determines which existing T- or B-Cells will proliferate in Periphery.
(NB: TCRs = T-Cell_{Antigen} Receptors; BCRs = B-Cell_{Antigen} Receptors)
- **Function:**
 - o To sense presence of Antigens in the Environment.
- **Ag-Receptor Specificity:**
 - o Ag-Receptors only respond to their Specific Antigen.
 - o Ag-Specificity is determined by the Amino-Acid Sequence at the Ag-Binding Site.
- **Generation of Ag-Receptor Diversity:**
 - o Enormous Diversity of Receptors is needed for a Huge Range of Constantly-Evolving Antigens.
 - o **During B- & T-Cell Development; (In 1^o Lymphoid Organs – BM & Thymus):**
 - **Ag-Receptor Gene Rearrangement (Ig-Gene (B-Cells); TCR-Gene (T-Cells)):**
 - **1st: Heavy Chain Rearrangement:**
 - o Random selection of 1xGene from Each of the **V, D & J** –Gene Loci, Then Recombination of these to make a functional gene.
 - o NB: this is the β -Chain in TCRs.
 - **2nd: Light Chain Rearrangement:**
 - o Random selection of 1xGene from Each of the **V & J** –Gene Loci, Then Recombination of these to make a functional gene.
 - o NB: this is the α -Chain in TCRs.
 - **(NB: Important Enzymes Involved in both B/T-Cell Receptor Gene Rearrangement)**
 - o **RAG-1 Recombinase**
 - o **RAG-2 Recombinase**
 - o **Ligases**



Above Left: BCR(Ig)-Gene Rearrangement; Above Right: TCR-Gene Rearrangement

- o **In B-Cells ONLY (In Periphery - Following B-Cell Activation):**
 - (I.e. T-Cells don't change after Ag-Binding, but B-Cells do)
 - In addition to Ag-Receptor Gene Rearrangement, B-Cells also undergo the following:
 - **Somatic Hypermutation (AKA: Affinity Maturation):**
 - – Single Amino-Acid Mutations are introduced into $V_{(Variable)}$ -Region-Genes.
 - Result = Activated B-Cells with \uparrow & \downarrow Ag-Affinity.
 - **New Ag-Receptors (BCRs) are tested for Increased Affinity:**
 - o Cells with Receptor Mutations that \downarrow Ag-Affinity \rightarrow Die.
 - o Cells with Receptor Mutations that \uparrow Ag-Affinity \rightarrow Survive.
 - $\rightarrow\rightarrow$ Proliferation of **High-Affinity B-Cells.**
 - **Ig-Class Switching:**
 - o – F_C Region-Genes of IgM are Replaced with F_C Region-Genes for IgG/IgA/IgE.
 - o **Requires $T_{H1/2}$ -Cell Help:**
 - **NB:** Cytokines from $CD4-T_H$ -Cells determine which Ab-Class is made.
 - **NB:** It is triggered at the time of B-Cell Activation & hence also Requires $CD40_{(B-Cell)}:CD40L_{(T-Cell)}$ Interaction. (NB: $CD128=CD40L$)
 - o $\rightarrow\rightarrow$ This change in Ab Constant-Regions \rightarrow Change in Ab Effector Function.
 - o **NB:** This doesn't affect Ab-Affinity.
 - o See 'Isotype Switching' in the Antibody section For Details.

- **BCRs (B-Cell Receptors):**

○ **Morphology:**

- **BCRs are Surface-Bound Antibodies** (Either IgM_(Monomeric) or IgG):

- **Immunoglobulin-Like-Structure:**

- Have a Pair of **Heavy Chains** & a Pair of **Light Chains**
- Each chain has a **Variable** and **Constant** region.

- **BCR Isotypes:**

- Naive B-Cells express IgM & IgD –Type BCRs.

○ **Functional Regions:**

- **Variable Region (F_{ab}):**

- BCRs (like Antibodies) Bind **Whole Antigen Directly**. (As opposed to TCRs which only recognise processed peptide presented on MHCs).

- **Constant Region (F_c):**

- Signal Transduction once bound to Ag.
- Internalisation of Ag for Processing & Presentation on MHC-II.

○ **Antigen Binding Sites** (Same for Abs):

- = the Variable Regions of partnered Heavy & Light Chains (V_H & V_L).

- Within these Variable Regions are Ag-Specific **Complementarity-Determining Regions (CDRs)**.

- These CDRs allow **binding of Intact Antigen** by adhering to epitopes on the outside of folded antigenic proteins. (See diagram)

- **NB: Typically, Ag's bind to Ab's via Non-Covalent Forces**, rather than chemically binding:

- I.e. Electrostatic Forces,
- Hydrogen Bonding,
- Van-der-Waal's Forces,
- Hydrophobic Forces.

○ **Generation of Ag-Receptor Diversity:**

- **(In 1^o-Lymphoid Organ - Bone Marrow)**

- Antigen-Receptor Gene Rearrangement

- **(In 2^o-Lymphoid Organs – Lymph Nodes/Spleen)**

- Somatic Hypermutation

- Ig-Isotype Switching

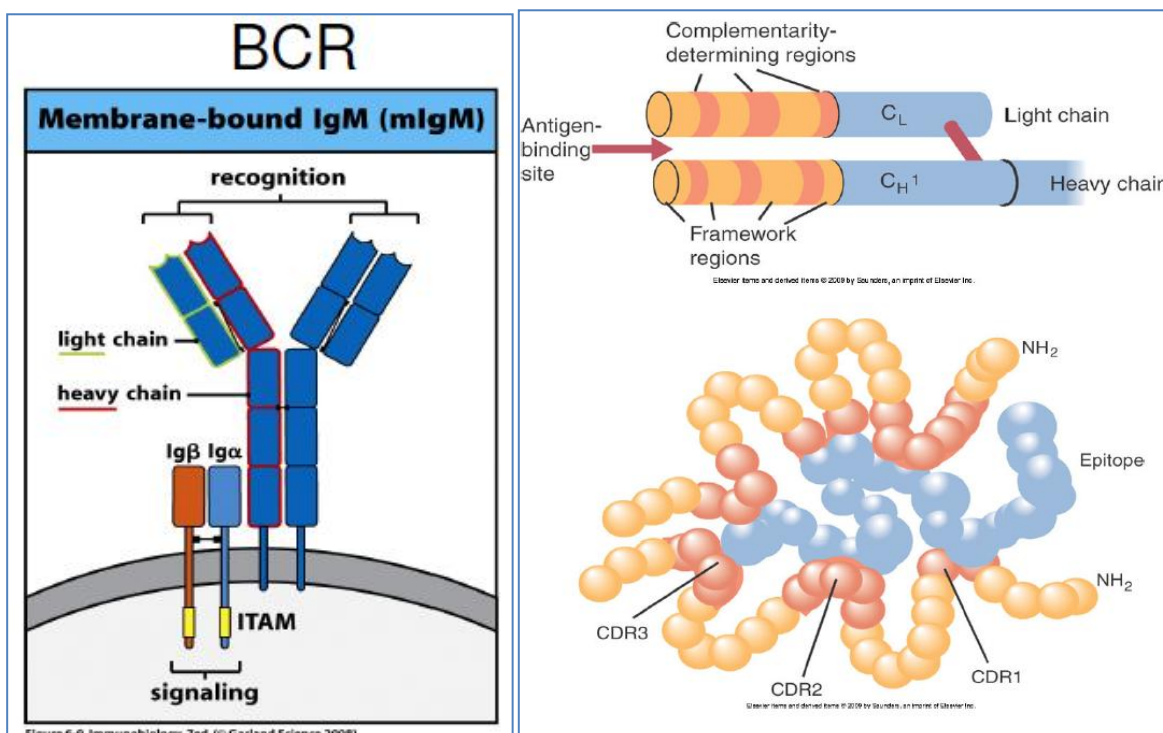


Figure 6-9 Immunobiology, 7ed. © Garland Science 2008

- **TCRs (T-Cell Receptors):**

○ **Morphology:**

- Are Membrane-Bound **Heterodimer** Receptors that **Resemble Antigen Binding Sites on Abs:**
- **Heterodimer** = Has a Pair of Chains (**Either α - β or γ - δ**) depending on T-Cell Lineage.
 - * **$\alpha\beta$ T-Cells Predominate** → CD4 (helper & regulatory) or CD8 T-Cells.
 - **$\gamma\delta$ T-Cells = Minority** → Mimic cells of the Innate Immune System → Reside in Lymphoid & Epithelial Tissues (Eg. Skin/Repro-Tract/GIT), & Recognise Whole Antigen (as opposed to $\alpha\beta$ T-Cells; - Recognise only Peptide:MHC complexes).
 - Each chain has a **Variable (V)** and **Constant (C)** region.
 - V & C Regions are Coded for by Separate Genes.

○ **Functional Regions:**

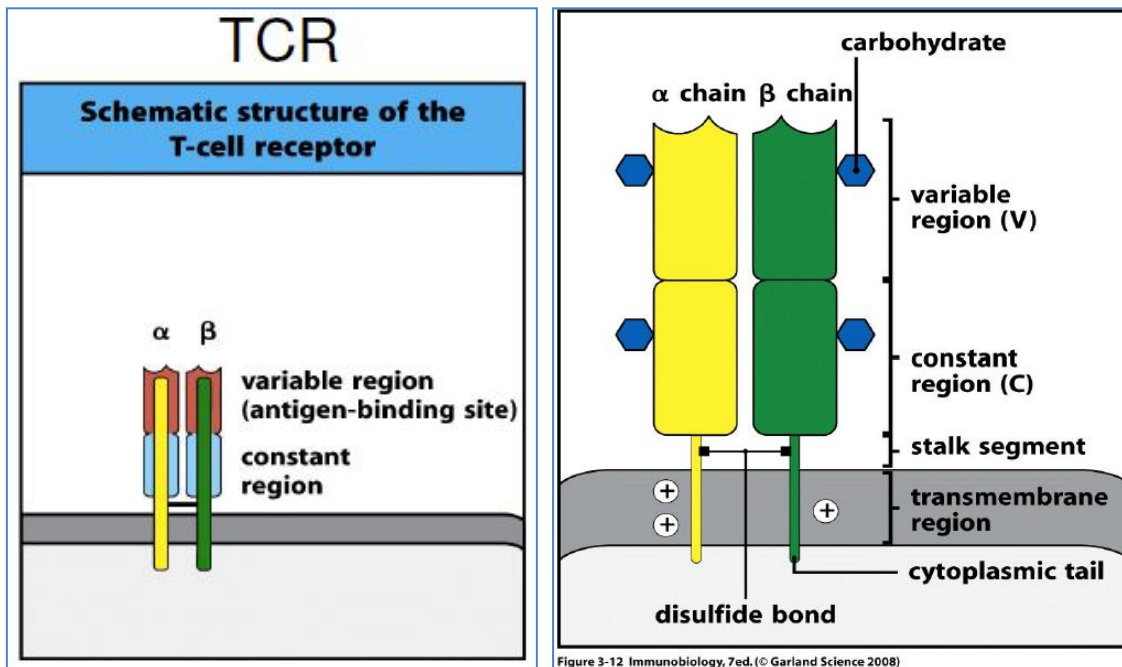
- **Variable Region (F_{ab}):**
 - **TCRs ONLY RECOGNISE Processed Peptide Complexed to MHC**
 - (on APCs, Semi-Activated Macrophages & Semi-Activated B-Cells).
 - Resembles Ag-Binding Site of Antibodies.
- **Constant Region (F_c):**
 - Signal Transduction once bound to Ag.

○ **Antigen Binding Sites (Same for Abs):**

- = the Variable Regions of partnered $\alpha\beta$ - or $\gamma\delta$ -Chains
 - **$\alpha\beta$ -Chains → Recognise Processed Peptide on MHC-I/II.**
 - **$\gamma\delta$ -Chains → Recognise Whole Antigen** (Similar to cells of Innate Immune System)

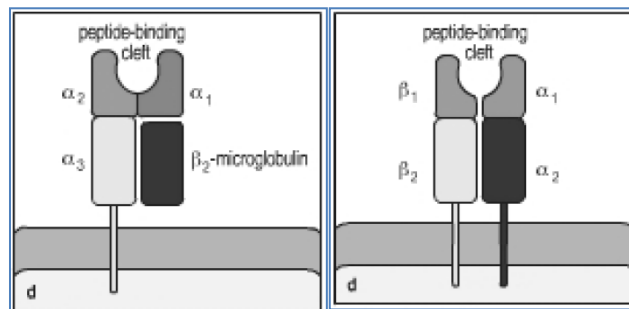
○ **Generation of Ag-Receptor Diversity:**

- (In 1^o-Lymphoid Organ - Thymus)
 - Antigen-Receptor Gene Rearrangement
- (NO Ig-Isotype Switching.)



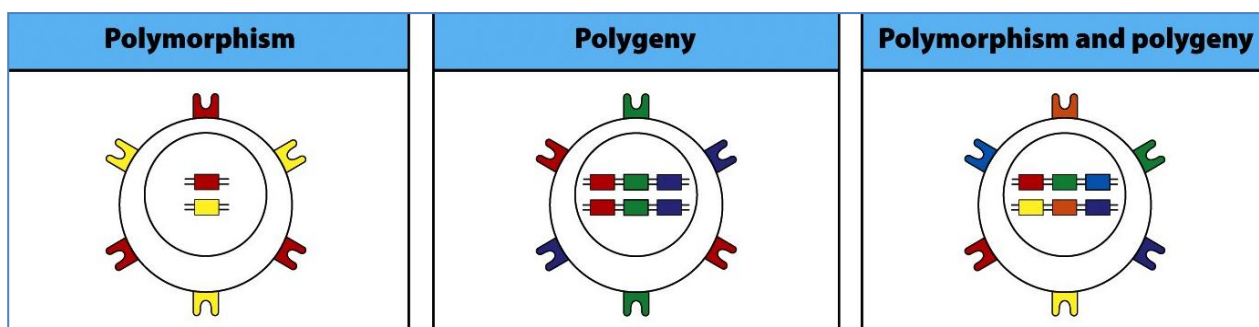
Major Histocompatibility Complex – MHCs (Self-Antigens):

- **NB: T-Cells can only recognise Ag when it is bound to Compatible MHC Molecules. (Not free Ag).**
 - o Therefore, MHC's Main Function = To *Enable T-Cells* to recognise Antigen.
 - o ***Epiphany : Classical MHC's are ONLY EVER RECOGNISED by T-Cells. No Other Cells do!**
- **What is MHC?**
 - o MHC is also known as HLA ("Human Leucocyte Antigens")
 - o Both MHC Classes are encoded by MHC Genes Located on the Short Arm of Chromosome 6.
 - o Are Cell Surface GlycoProteins – ie. "Self Antigens":
 - High diversity of MHC throughout the population
 - (ie. Different people have different 'Self-Antigens')
 - – The Basis of Transplant Rejection.
 - NB: Identical twins have the same MHC's.
 - o **Molecular Structure:**
 - **Structure of MHC-I:**
 - 2 Polypeptide chains
 - NB: One of the chains contains a β_2 Microglobulin which *Isn't* coded by MHC genes.
 - Only has 1x Intracellular Domain
 - **Structure of MHC-II:**
 - 2 Polypeptide Chains
 - Both domains of MHC-II are encoded by MHC Genes.
 - Has 2x Intracellular Domains



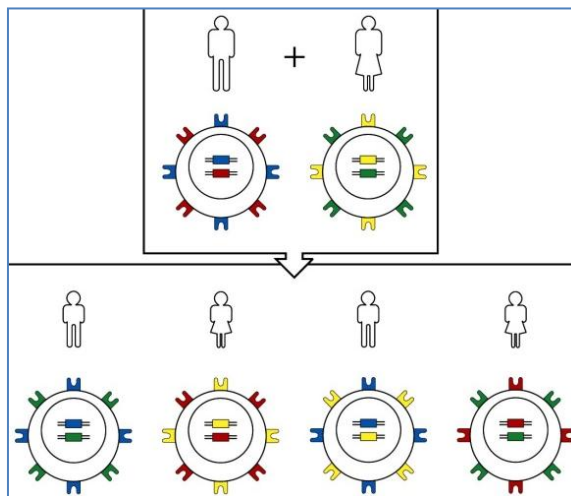
MHC Diversity – Due to Polygeny & Polymorphism:

- o **Polygeny:**
 - There are Several Different Class I & II Genes throughout the population that seem to have the same functions.
 - NB: Each of the genes have different locations on Chromosome 6.
 - There are 3x Class-I Genes:
 - HLA-A
 - HLA-B
 - HLA-C
 - There are 3x Class-II Genes:
 - HLA-DR
 - HLA-DP
 - HLA-DQ
- o **Polymorphism:**
 - There are hundreds of Alleles of the above genes dispersed throughout the population.
 - NB: Expression of MHC Genes is **Codominant** (Ie. People are usually Heterozygous for different MHC alleles – and Express BOTH)



- **MHCs Are Remarkably Similar Amongst 1st-Degree Relatives. Why?**

- **MHC Haplotypes** – **Linked sets of MHC Genes**, which are located at *Multiple Loci* on a single Chromosome, but are *close enough together* that they are *Inherited Together* as a Package.
- I.e. Haplotypes are too close together to be subject to Meiotic 'Cross-Over' (or 'Snapsis').

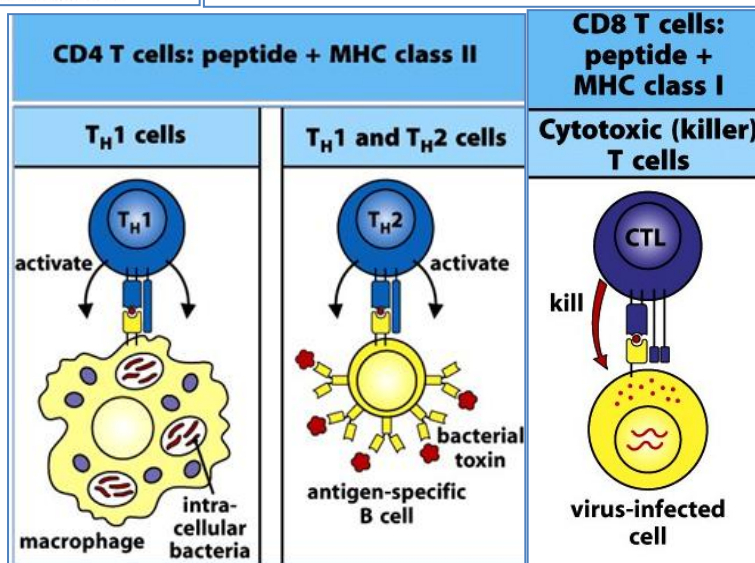
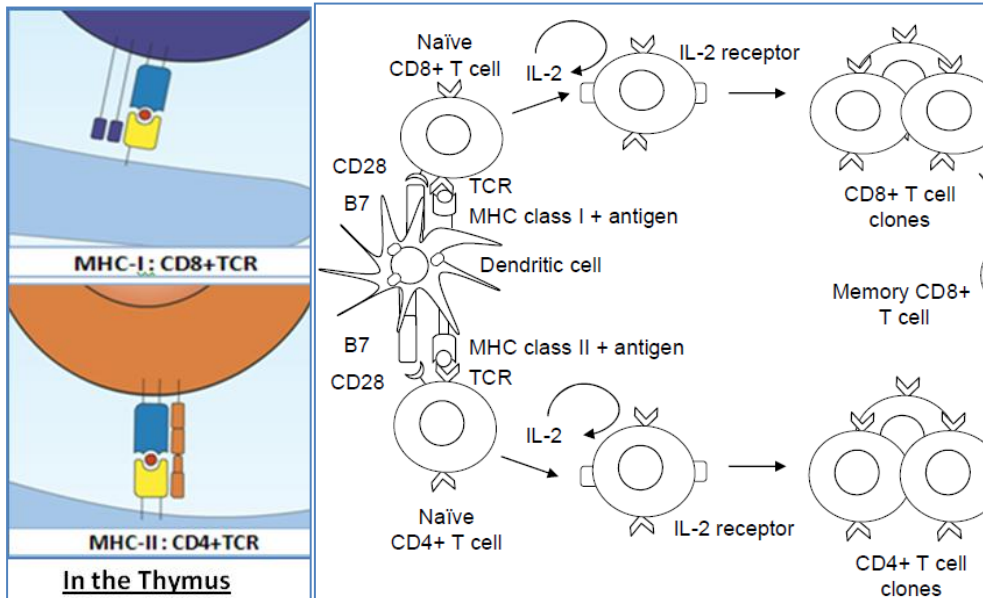


- **There are 3 Classes of MHCs & Their Specific Functions:**

- ***Class-I-MHCs:**
 - **Found on ALL Nucleated Cells & APCs. (These are the 'Self-Antigens')**
 - NB: Not Expressed on Red Blood Cells
 - - allow **Positive & Negative Selection of CD8-T-Cells** [in the Thymus].
 - - allow APCs to Present **Viral/Cancer Peptides to Cytotoxic T-Cells**.
 - - allow **Virally-Infected/Cancerous cells to be Targeted & Killed by Cytotoxic T-Cells**
- ***Class-II-MHCs:**
 - **Found ONLY on APCs & Semi-Active Macrophages & Semi-Active B-Cells.**
 - NB: Not Expressed on Red Blood Cells
 - - allow **Positive & Negative Selection of CD4-T-Cells** [in the Thymus].
 - - allow APCs to Present Antigen to Naive T_H-Cells → **Activates T_H-Cells to → Effector Cells.**
 - - allow **Partially-Activated Macrophages to Request T_H-Cell Help** → **More Phagocytic.**
 - - allow **Partially-Activated B-Cells to Request T_H-Cell Help** → **Fully Active B-Cells → Ab's.**
- **Class-III-MHCs:** Important in Complement & Cytokine production.

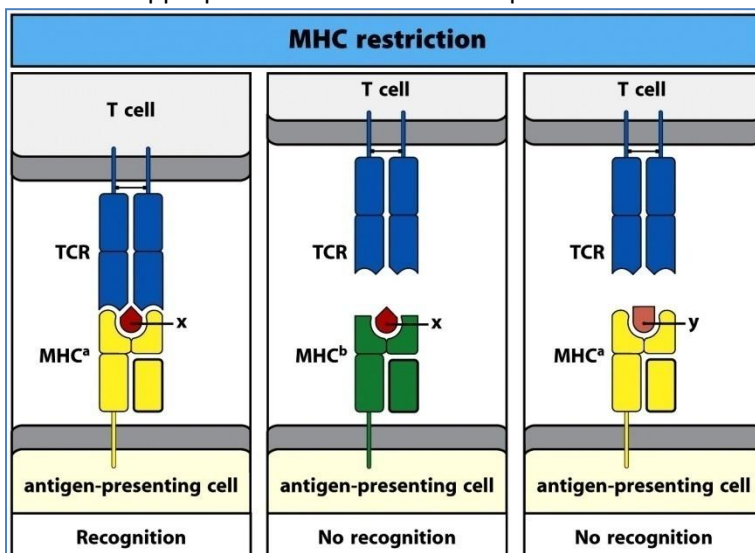
- **Summary of MHC Functions:**

- **Facilitate Antigen Presentation by APCs to T-Cells. (CD4 & CD8 – Depending on MHC Class):**
 - [In the Thymus] APCs → **Facilitate Positive & Negative Selection of CD4 & CD8 T-Cells.**
 - [Outside Thymus]APCs→**Alert Corresponding CD4 & CD8 T-Cells to the Presence of Antigen**
 - **NB. Remember:** T-Cell Specificity is *Genetically Determined* & therefore, Presentation of Ag to T-Cells only really *Alerts* the Relevant T-Cells to the *Presence* of Ag, and stimulates them to become Effector T-Cells. (I.e. APCs don't "*Sensitise*" T-Cells to Antigen, they just *Alert* them)
- **Allow Partially-Activated Macrophages to Request T_H-Cell Help:**
 - T_H-Cells help Macrophages to Become Fully Active → **More Phagocytic.**
- **Allow Partially-Activated B-Cells to Request T_H-Cell Help:**
 - T_H-Cells help B-Cells → B-Cells Become Fully Activated → **Secrete Antibodies.**
- **Allow Virally-Infected/Cancerous somatic cells to be Targeted & Killed by T_C-Cells:**
 - T_C-Cells recognise pMHC-I presented on virally-infected/cancerous cells → **Kill Cells.**



- **What is “MHC Restriction”?:**

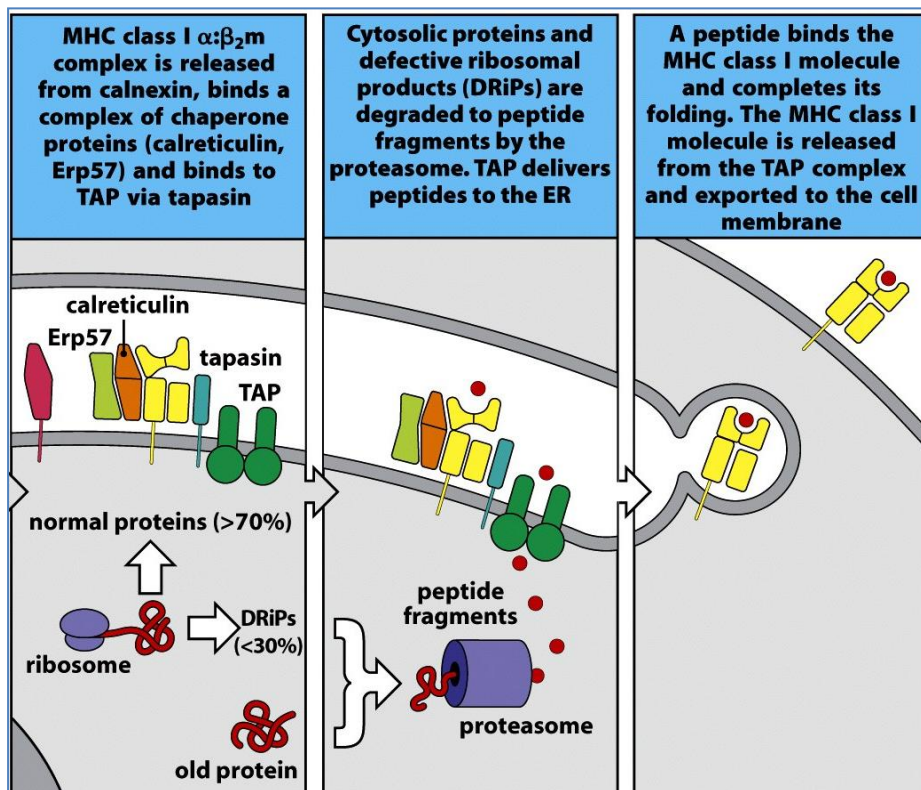
- **T-Cell Antigen Recognition is “MHC-Restricted” Meaning:**
 - A T-Cell Receptor (TCR) will only bind to a Peptide-MHC Complex on 2 Conditions:
 - 1) The MHC Molecule is Compatible
 - 2) The Peptide displayed is Specific to that TCR.
- **NB: Some Pathogens Disable MHC Restriction by Production of *Superantigens*.**
 - Leads to→ Inappropriate activation of Non-Specific T-Cells→ Maladaptive Immune Response



- **The 2 Mechanisms of Attaching Peptide to MHC and Delivering it to the Surface:**

o **Peptide Presentation by MHC-I:**

- **Antigens presented on MHC-I are typically *Endogenous*** (i.e. Are synthesized within the cell), and are often the result of Viral-Infection/Genetic Mutation/Cancer.
 - - Allows T_C-Cells to recognise “*Altered Cells*” and target them for destruction.
- **Antigen Proteins Must First be Broken Down into Peptides:**
 - **How? – By *Proteasomes* = Proteolytic structures in the Cytosol which Degrade--:**
 - o Defective Ribosomal Products (DRiPs)
 - o Old Cytosolic Proteins
 - o Viral Proteins
 - o Cancer/Mutated Proteins.
- **Peptide Fragments are Loaded onto MHC-I *Inside the Endoplasmic Reticulum*.**
 - Therefore, *Cytosolic* Peptide Fragments must be *Transported* into the ER.
 - **How? – By “*TAP*” Transporters in ER Membrane:**
 - o TAP Transporters → Carry Peptides from the Cytosol to the ER.
 - ‘*Chaperone Proteins*’ are important in loading Peptide onto MHC-I:
 - o Peptide Fragments freely bind to MHC-I in the ER.
- **pMHC-I is then sent to the Surface where it will interact with CD8-T_C-Cells.**



NB: Viruses can block many of the above stages to prevent pMHC-I Presentation.

NB: Defects in TAP can also prevent pMHC-I Presentation.

- **Peptide Presentation by MHC-II:**
 - **Antigens presented on MHC-II are typically *Exogenous*** (i.e. From extracellular pathogens), which have been phagocytosed and degraded into peptide fragments.
 - - Allows new/novel antigens to be presented to the immune system.
 - - However, it requires an Acidic Environment.
 - **Antigen Proteins Must First be Broken Down into Peptides:**
 - **How? – By Acid in Phagolysosomes:**
 - Any Extracellular Antigen is Phagocytosed into an Phagosome.
 - The Phagosome is then Fused with an Acid-Filled Lysosome.
 - Acid in the resultant Phagolysosome Denatures Protein and Activates Proteases.
 - Antigen is broken down into Peptide Fragments.
 - **Q: So How does MHC-II Protect Itself in a Low pH Environment?:**
 - **A: By associating with a “Class-II-associated Invariant Chain Peptide”(CLIP):**
 - **NB: Really Crappy Acronym (Invariant Chain = ‘I’)**
 - **Functions of the ‘Invariant Chain’ (CLIP):**
 - **1) Blocks the Peptide-Binding-Groove on MHC while inside the ER & also during exogenous protein-degradation in Acidic Lysosomes.**
 - **2) Targets the Delivery of MHC to *Acidic Lysosomes*** (i.e. Prevents MHC binding to peptide in non-phagocytic compartments)
 - **Peptide Fragments are Loaded onto MHC-II *Inside the Endocytic Vesicles:***
 - **NB: There will be Many Different Peptides of the same Antigen in a single Lysosome.**
 - **HLA-DM Molecules** (which are also present in lysosomes) are **activated by Low pH** → and releases **CLIP** from MHC-II → Allows *Antigenic Peptides* to bind.
 - **pMHC-II is then Sent to the Surface where it will interact with CD4-T_H-Cells.**

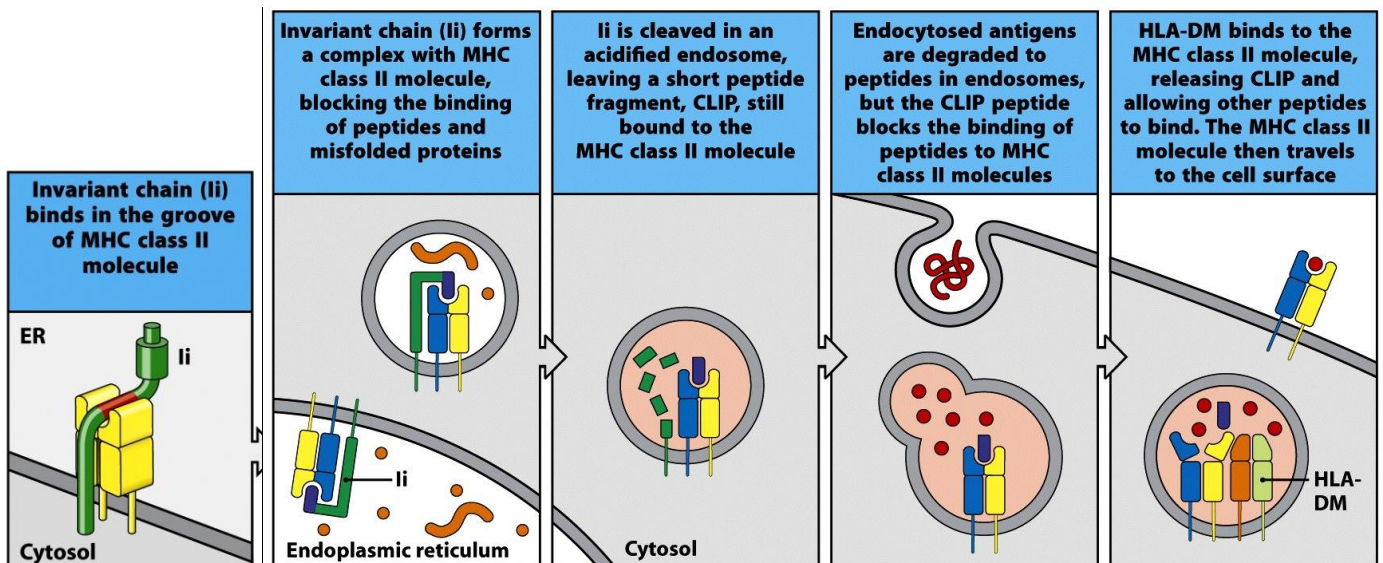


Figure 5-9 part 2 of 2 Immunobiology, 7ed. (© Garland Science 2008)

Figure 5-11 Immunobiology, 7ed. (© Garland Science 2008)

Summary of Peptide Presentation by MHC-I & MHC-II:

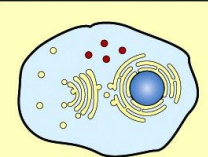
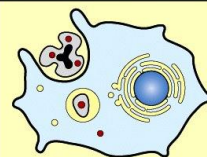
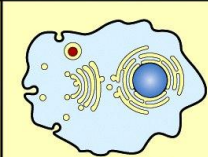
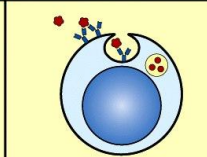
	Cytosolic pathogens	Cross-presentation of exogenous antigens	Intravesicular pathogens	Extracellular pathogens and toxins
	 any cell	 macrophage	 macrophage	 B cell
Degraded in	Cytosol	Cytosol (by retrotranslocation)	Endocytic vesicles (low pH)	Endocytic vesicles (low pH)
Peptides bind to	MHC class I	MHC class I	MHC class II	MHC class II
Presented to	Effector CD8 T cells	Naive CD8 T cells	Effector CD4 T cells	Effector CD4 T cells
Effect on presenting cell	Cell death	The presenting cell, usually a dendritic cell, activates the CD8 T cell	Activation to kill intravesicular bacteria and parasites	Activation of B cells to secrete Ig to eliminate extracellular bacteria/toxins

Figure 5-2 Immunobiology, 7ed. (© Garland Science 2008)

“Superantigens”:

- Bacterial or Viral Antigens that *Non-Specifically* activate T-Cells *Without being Processed by APCs*.
 - I.e. They are able to facilitate TCR-MHC interaction without satisfying *either criteria for Compatibility*:
 - 1) The MHC Molecule doesn't need to be Compatible with the TCR.
 - 2) The Peptide displayed on MHC doesn't need to be Specific to that TCR.
- NB: Bacterial Superantigens are free in plasma; Whereas Viral Superantigens are Membrane-Bound.
- Resulting T-Cell responses are *Non-Specific* & are therefore *Maladaptive* for host but *Helpful* to the Pathogen.
 - Since T-Cell activation is non-specific, it activates a *HUGE* number of T-Cells → Produce Cytokines.
 - ↑↑↑Excess Cytokines can lead to → Cytokine Toxicity. AKA: “Cytokine Storm”, which can lead to → “Toxic Shock Syndrome”:
 - ↓BP (& Postural Hypotension)
 - Tachycardia
 - Fever
 - Myalgia
 - Dizziness
 - Rash
 - Treatment of Toxic Shock Syndrome:
 - Aggressive Symptomatic Treatment
 - Aggressive Antibiotics/Antivirals for the Pathogen.

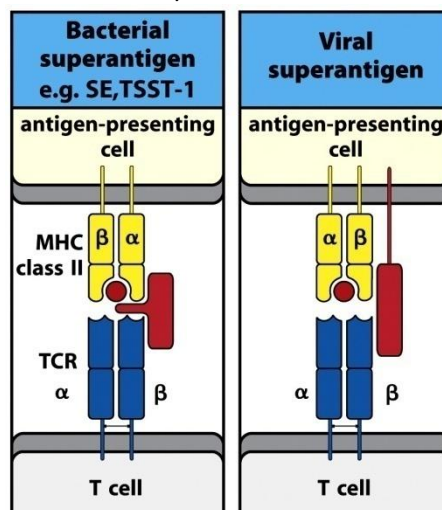


Figure 5-22 part 1 of 2 Immunobiology, 7ed. (© Garland Science 2008)

PAMPs – Pathogen Associated Molecular Patterns:

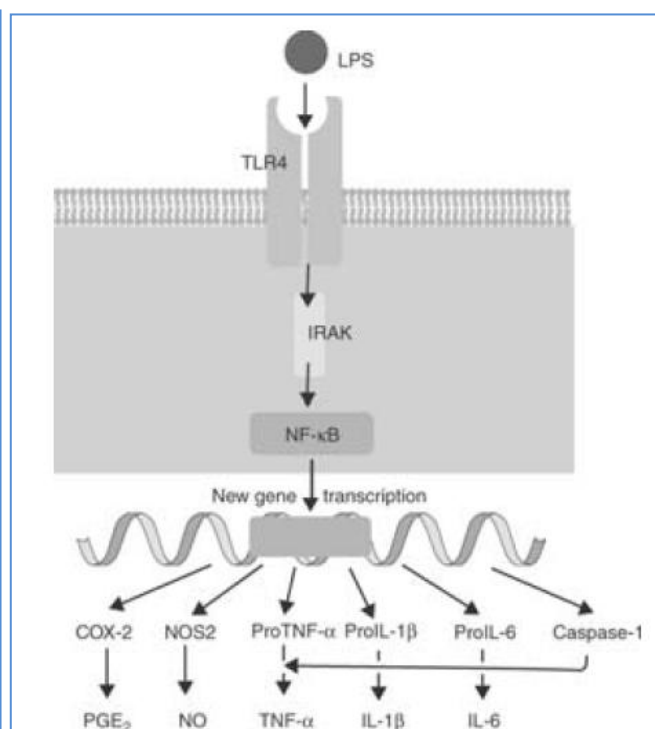
- **Molecules Regularly expressed on the surface of Pathogens, but NOT on the Body's own Cells.**
- They allow Rapid Recognition of Invaders by the Innate Immune System → Rapid Immune Response.
 - (Recognition of PAMPs is via Toll-Like Receptors (TLR's) & Pathogen-Recognition Receptors (PRRs))
- Hence, they provide a mechanism for Non-Specific immunity, until a More Specific Defence can be mounted by the Adaptive Immune System.
- **PAMPs are typically critical to the pathogen's function & cannot be eliminated through evolution. Such conserved features in pathogens include:**
 - **Bacterial PAMPs:**
 - **Lipopolysaccharides (LPS) – Found on Gram-Negative Bacteria. Recognised by TLR-4.**
 - Flagellin (from Bacterial Flagella) – Found on Gram-Positive Bacteria. Recognised by TLR-5.
 - Lipoteichoic Acid – Found on Gram-Positive Bacteria. Recognised by TLR-2.
 - Lipoarabinomannan (LAM) – Associated with Tuberculosis Bacteria (Gram Positive). Recognised by TLR-2.
 - **Viral PAMPs:**
 - Double-Stranded RNA (dsRNA) – Recognised by TLR-3.
 - Viral DNA

TLR's – Toll-Like Receptors:

- **A Class of Pattern-Recognition Receptors that play a key role in the Innate Immune System by recognising PAMPs on Microbes.**
- There are ~15 different TLRs Primarily **Expressed on Antigen-Presenting Cells** (Dendritic Cells, Macrophages, & B-Lymphocytes).
- **Different TLRs can recognise multiple different PAMPs on different microbes.** (I.e. Have *Low Ag-Specificity*)
- **Major TLRs & Their Ligands:**
 - ***TLR-4: Recognises LPS (Lipopolysaccharide) – found on Gram-Negative Bacteria.**
 - **TLR-5: Recognises Flagellin on Gram-Positive Bacteria.**
 - **TLR-2: Recognises Lipoteichoic Acid (Gram-Positive) & Lipoarabinomannan (LAM) on TB.**
 - **TLR-3: Recognises Double-Stranded RNA (dsRNA) on Viruses.**
- **Activated TLR's → Activate Transcription Factors → Causing the Production & Release of Cytokines (Including Chemokines) → Alert & Attract the Immune System to the Microbe.**
 - NB: Cytokines produced depend on specific TLR stimulated.

Innate immune recognition by Toll-like receptors	
Toll-like receptor	Ligand
TLR-1:TLR-2 heterodimer	Peptidoglycan Lipoproteins Lipoarabinomannan (mycobacteria) GPI (<i>T. cruzi</i>) Zymosan (yeast)
TLR-2:TLR-6 heterodimer	
TLR-3	dsRNA
TLR-4 dimer (plus MD-2 and CD14)	LPS (Gram-negative bacteria) Lipoteichoic acids (Gram-positive bacteria)
TLR-5	Flagellin
TLR-7	ssRNA
TLR-8	G-rich oligonucleotides
TLR-9	Unmethylated CpG DNA

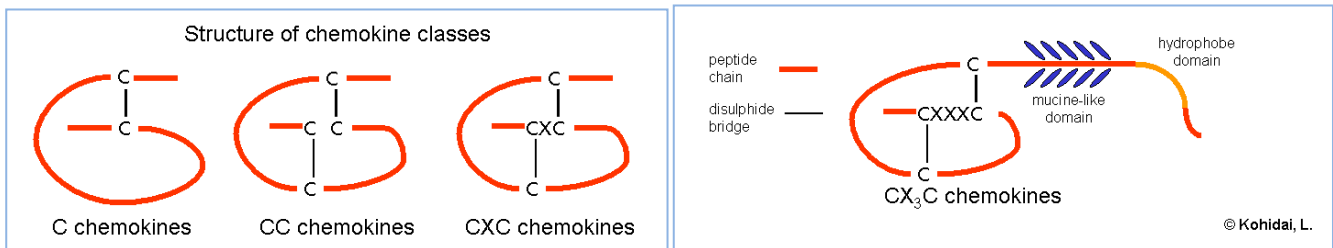
Figure 2-16 Immunobiology, 7ed. © Garland Science 2008



Cytokines:

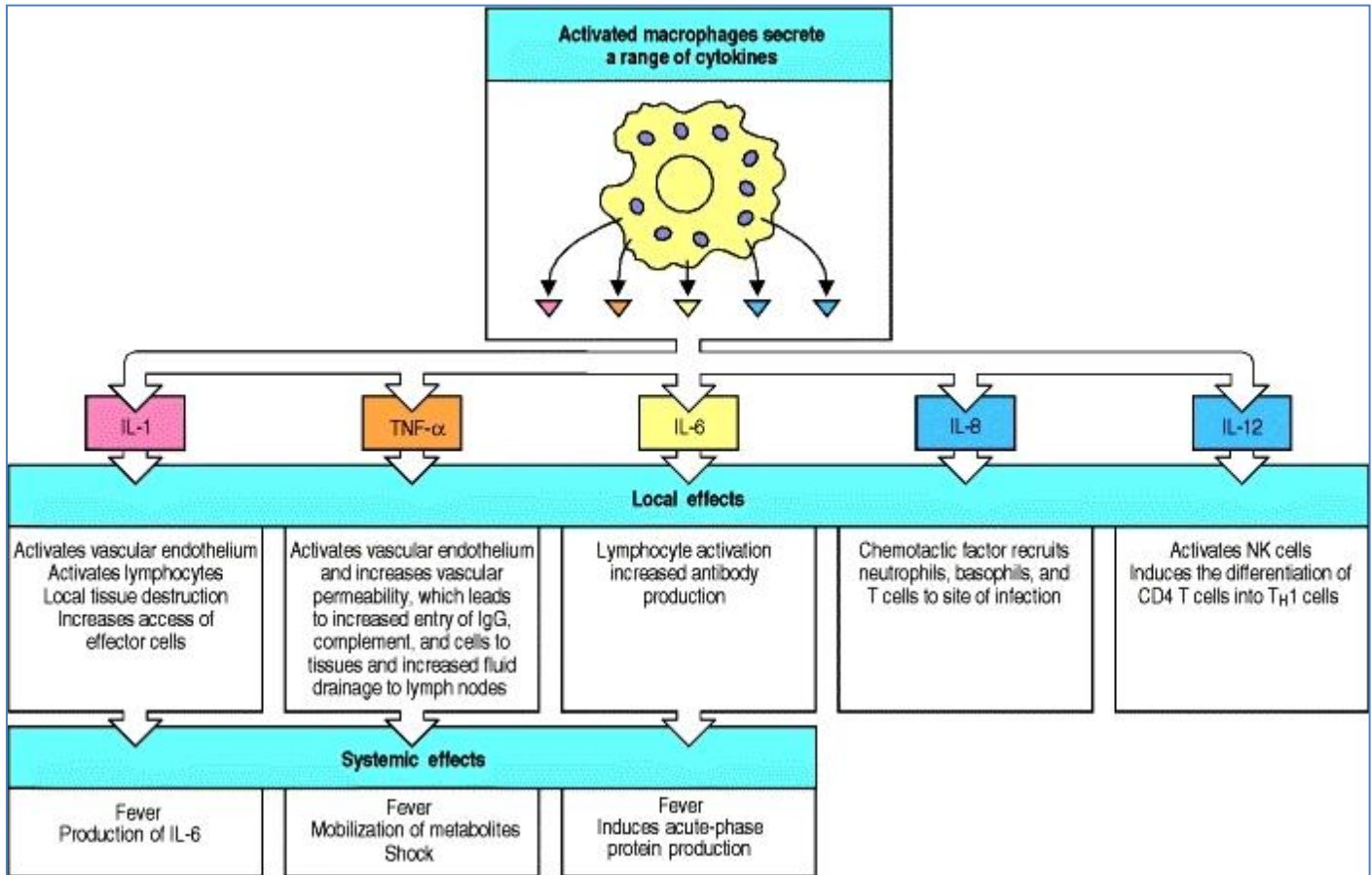
Literally: proteins made by cells that affect the behaviour of other cells. They act via specific cytokine receptors on the cells that they affect.

- **Regarding the Immune System:** The collective group of chemical messengers involved in the Adaptive Immune Response, released following the activation of Toll-Like Receptors (TLR's) → i.e. Hormones that promote inflammation and attract WBC's to the site of infection, by stimulating Immune-Cell Development, Differentiation & Responses. **They include:**
 - **Interleukins:** ("Between Leukocytes") Group of over 35 cytokines first seen to be produced by Leukocytes (WBC's) and act on Leukocytes. However, it has since been found that Interleukins are also produced by a variety of other body cells, the majority of which from Helper-(CD4)-T-Lymphocytes, as well as monocytes, macrophages and endothelial cells. They Promote Development & Differentiation of T, B, & Haematopoietic Cells.
 - **Chemokines:** 4 Groups of Cytokines named by their ability to induce Chemotaxis (Migration) in nearby cells; hence they are **Chemotactic Cytokines**. Receptive cells detect the concentration of Chemokine, & then move up the concentration gradient to where the cell is required.
 - Chemokines are classified into 4 groups based on the spacing of their 1st two Cysteine residues: **C-Chemokines, CC-Chemokines, CXC-Chemokines & CX₃C-Chemokines**.
 - Each group binds to different chemokine receptors (which are expressed on different cell types), hence different cells are attracted to different chemokines.
 - **MCP-1:** Macrophage Chemoattractant Protein. It is a CC chemokine also known as CCL-2 → Binds to CC Receptors on Monocytes (Macrophages).
 - **IL-8:** The only chemokine originally named an Interleukin. It is a CXC Chemokine also known as CXCL-8 → binds to CXC Receptors on Granulocytes, Monocytes & CD8 T-Cells.



NB: In this diagram, an 'X' represents an Amino Acid.

- **Lymphokines:** Group of Cytokines named due to their production by Lymphocytes (Typically T-Cells). They attract other immune cells (Chemotaxis), like macrophages & other lymphocytes, to an infected site and prepare them to attack the invaders.
- **How do they Act on Cells?**
 - They induce cellular responses by binding with specific cytokine receptors.
 - They can act in an —
 - **Autocrine** manner (affecting the cell that released them – Eg. Chemokines),
 - a **Paracrine** manner (affecting the adjacent cells – Eg. Chemokines),
 - or, if stable enough, an **Endocrine** manner (affecting distant cells – Eg. Acute Phase Cytokines & Pyrogens.)
 - NB: the above depends on their ability to enter Circulation & also their Half-Life in blood.
- **Important Cytokines:**
 - **IL-1, IL-6 & TNF_α** —
 - Critical to the **Acute Phase Response** (or Synthesis of Acute Phase Proteins) Some **Acute Phase Proteins** mimic the action of Antibodies, but have broad specificity for PAMPs and depend only on the Cytokines for their production.
 - Mobilise Neutrophils from bone marrow.
 - Pyrogenic effects on the Hypothalamus
 - Stimulate Dendritic Cells to mobilise → Initiate Adaptive Response.
 - **IL-8** – A Chemokine secreted by Monocytes, Macrophages & Injured Epithelium. Attracts Granulocytes, Monocytes (Macrophages) & CD8-(Cytotoxic)-T-Cells
 - **IFN_γ (Interferon-Gamma)** – the major cytokine-activator of Macrophages. (Produced by T-Helper cells, T-Cytotoxic Cells & NK-Cells).



Cytokine	Cell source	Target	Actions
Proinflammatory Cytokines			
IL-1	Macrophage Dendritic cell	Lymphocytes Endothelial cell CNS Liver	Enhances responses Activates Fever, sickness behavior Synthesis and release of acute-phase proteins
IL-6	Macrophage Dendritic cell Endothelium Th2 cell	Liver B cell	Synthesis and release of acute-phase proteins Proliferation
TNF-alpha	Macrophage Dendritic cell Th1 cell	Endothelial cell Neutrophil Hypothalamus Liver	Activates vascular endothelium – increased permeability and stimulates adhesion molecules Activates Fever Synthesis and release of acute-phase proteins
Anti-inflammatory Cytokines			
IL-10	Macrophage Th2	Macrophage Dendritic cell	Inhibits IL-12 production Inhibits pro-inflammatory cytokine synthesis
IL-12	Macrophage Dendritic cell	CD4+T helper cell NK cell	Th1 differentiation IFN-gamma synthesis
Cytokines Involved in the Acquired Immune Response			
IL-2	T cell	T cell NK Cell B cell	Proliferation Activation and proliferation Proliferation
IL-4	Th2 cell Mast cell	T cell B cell Macrophage	Th2 cell development/proliferation Isotype switch to IgE Inhibit IFN-gamma activation
IFN-gamma	Th1 cell Cytotoxic T cell NK cell	T cell B cell Macrophage	Th1 cell development Isotype switch to IgG Activation

The Cells of the Immune System Derive from Precursors in the Bone Marrow:

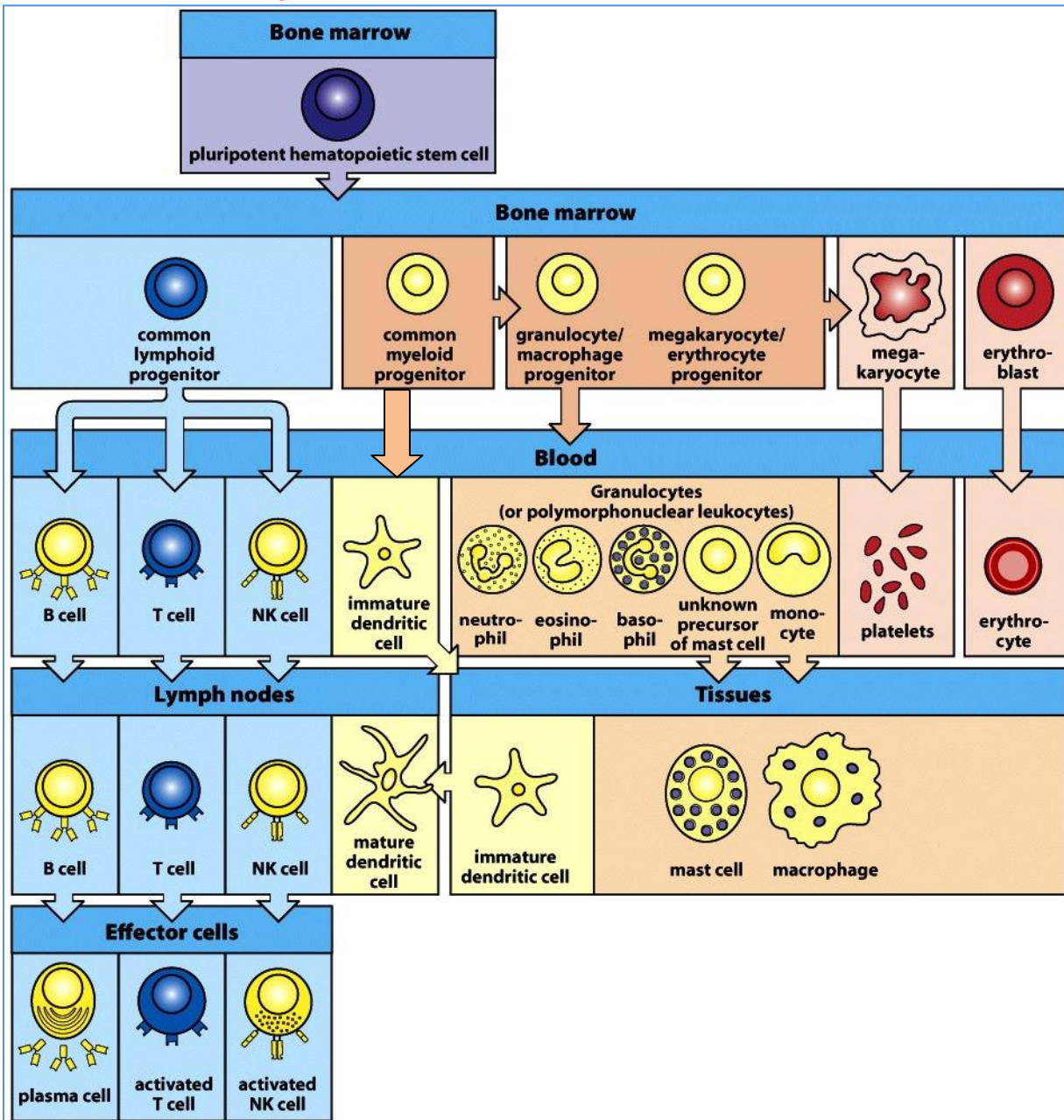


Figure 1-3 Immunobiology, 7ed. (© Garland Science 2008)

Blood Cell Counts:

Cell type	Normal range / L	Percentage
Polymorphonuclear Leucocytes (Granulocytes)		
Neutrophils	2.5 - 7.5 x 10 ⁹ /L	40 - 75%
Eosinophils	0.04 - 0.4 x 10 ⁹ /L	1 - 6%
Basophils	0.01 - 0.1 x 10 ⁹ /L	0 - 1%
Mononuclear Cells		
Monocytes	0.2 - 0.8 x 10 ⁹ /L	2 - 10%
Lymphocytes	1.0 - 3.5 x 10 ⁹ /L	20 - 45%

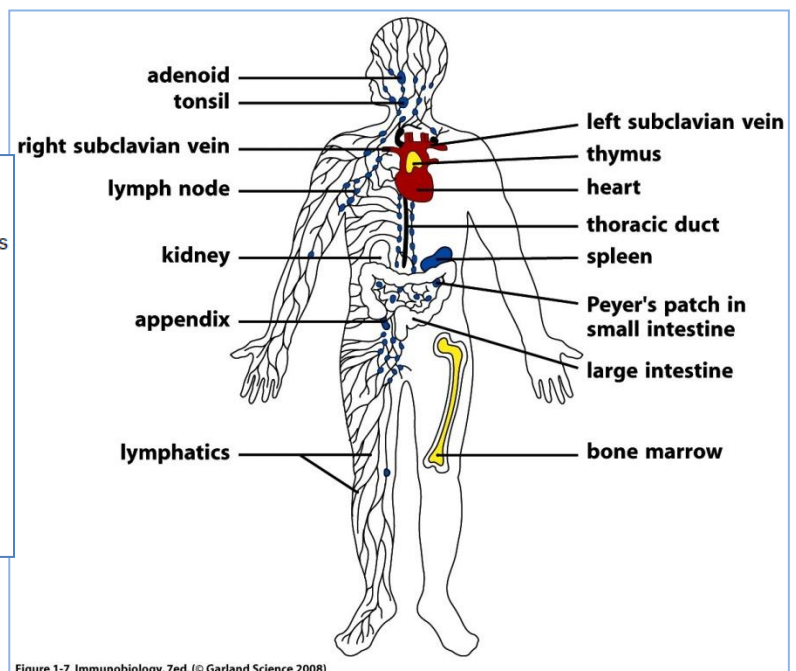
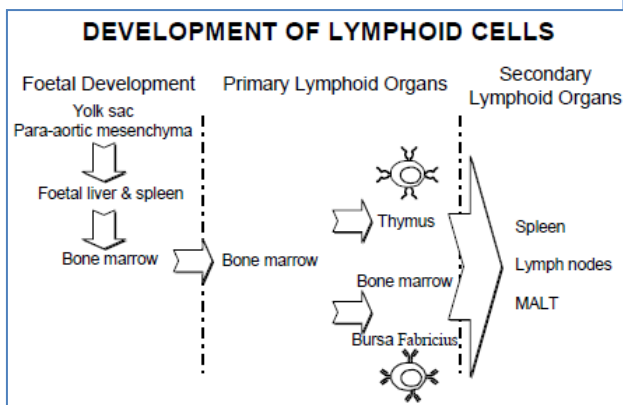
In 2009 final year exam 30% of students given a blood report in cells/litre could not work out the concentration in cells/ml

Lymphoid Organs:

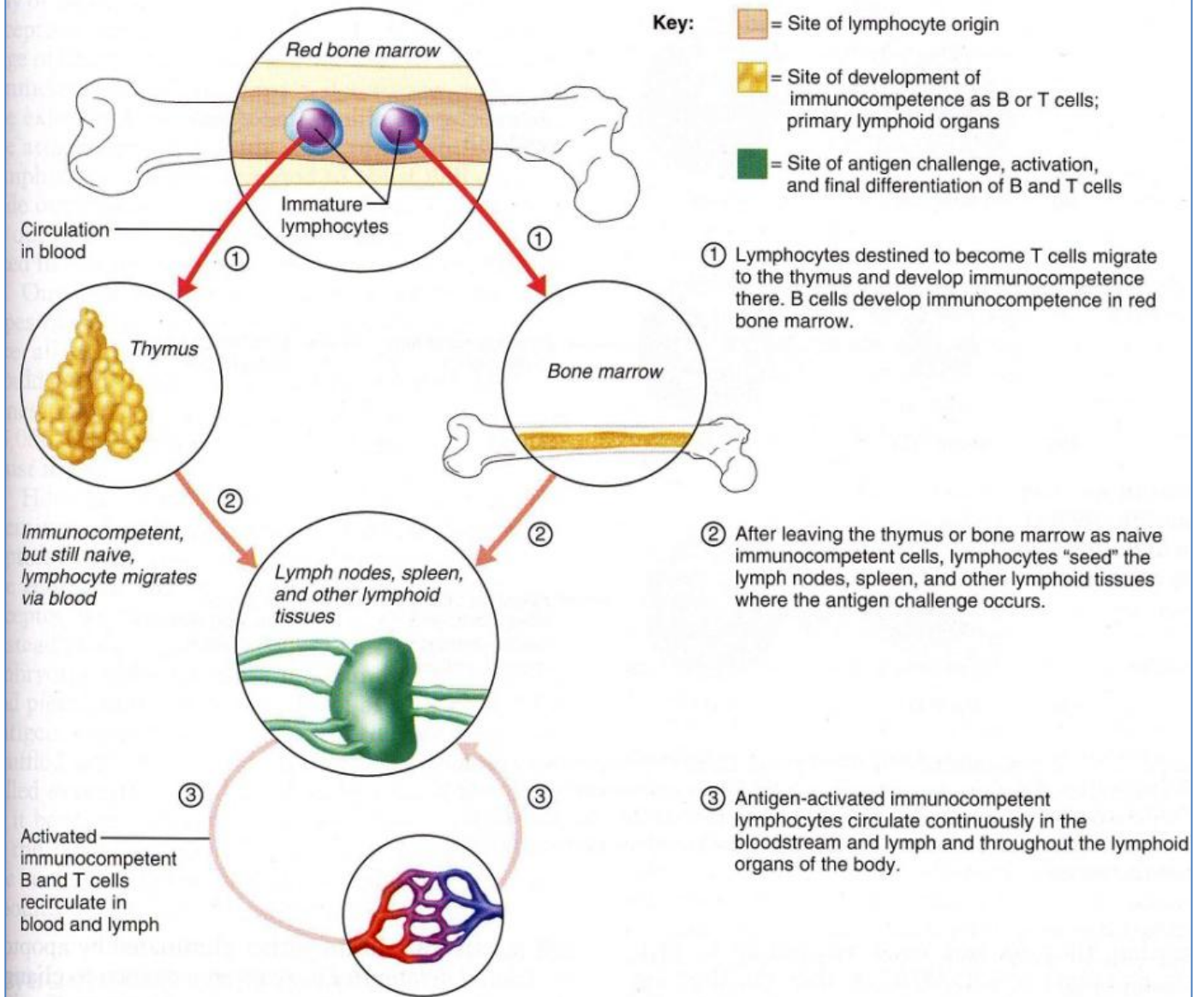
- **Lymphoid Tissue in General:** Composed of a type of loose Conn.Tissue called Reticular Connective Tissue. Macrophages live on the fibres of the Reticular Network, and huge numbers of Lymphocytes reside Temporarily in the spaces amongst the Reticular Network.
 - o **NB: Lymphocytes are constantly circulating between the Blood Vessels, the Lymphatic System & Lymphoid Tissues** to ensure that they are readily available to attend to infected/damaged sites quickly. For more on lymphocyte circulation, see **"Cell Adhesion Molecules"**.

- **1. Primary Lymphoid Organs:** Lymphoid organs where Lymphocytes (B&T) Develop & Mature (I.e. Become Immunocompetent). 'Immunocompetent' lymphocytes display specific Antigen Receptors on their surfaces, enabling them to recognise & bind to ONE specific antigen.
 - o **Sites of Lymphocyte Maturation:**
 - **Red Bone Marrow: Site of B-Cell Maturation**
 - **Thymus: Site of T-Cell Maturation.**
 - o **Basics of Immunocompetence (Maturation) =**
 - **1.** T/B-Cell must be able to bind MHCs, since it is on these MHCs that Antigens are presented to it for recognition.
 - **& 2.** The T/B-Cell must not react strongly to Self-Antigens normally found in the body. Developing T-Cells that don't fit these criteria are eliminated via Apoptosis.

- **2. Secondary Lymphoid Organs:** (All other Lymphoid organs) - Those in which Naive Lymphocytes (mature, but virgin) encounter Antigens for the first time & are stimulated to become Effector & Memory Cells:
 - o **Lymph Nodes**
 - o **Spleen**
 - o **Mucosa-Associated Lymphoid Tissue (MALT)**
 - o **Tonsils**
 - o **Peyer's Patches (Liver)**
 - o **Adenoids**
 - o **Skin**



Adaptive defenses → Humoral immunity
 Adaptive defenses → Cellular immunity

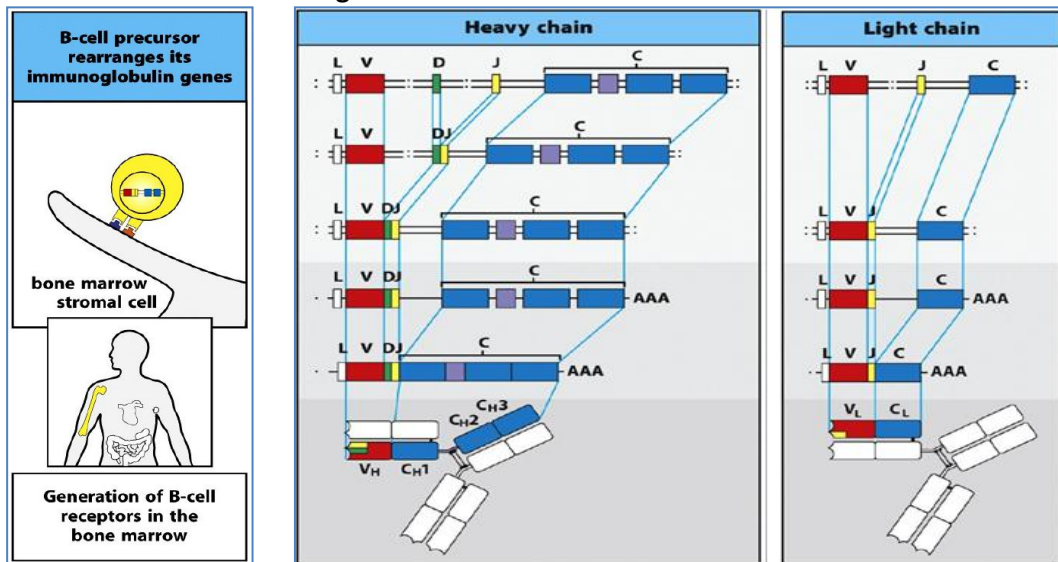


Lymphocyte Development & Activation:

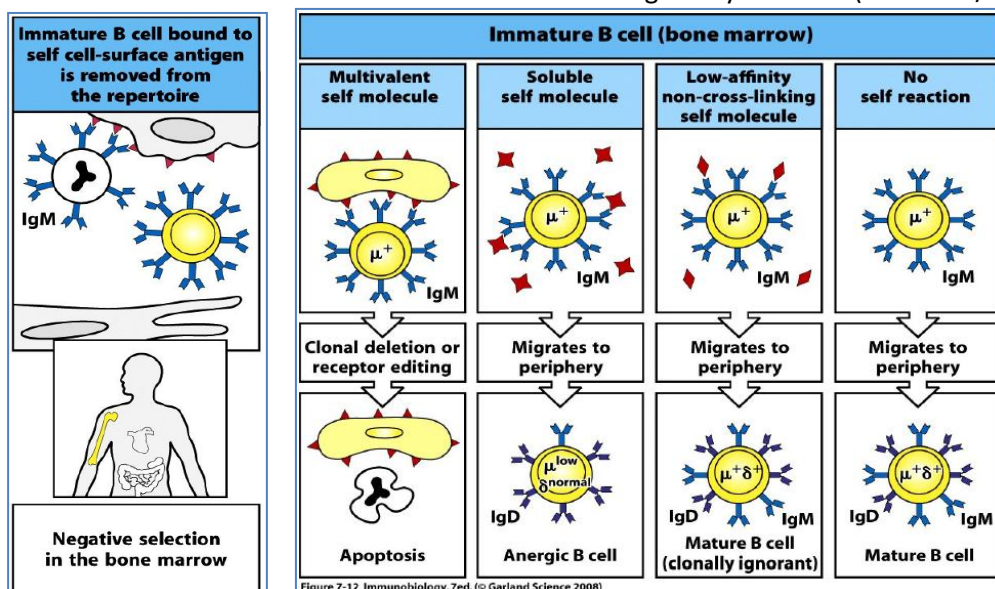
- **NB: All Lymphoid Cells (B-Cells/T-Cells/NK-Cells) are derived from Lymphoid Progenitors in Bone Marrow.**
 - o **B-Cell Precursors** - stay in Bone-Marrow, where they become Mature, Naive B-Cells.
 - o **T-Cell Precursors** - migrate to the Thymus, where they become Mature, Naive T-Cells.

B-Cell Development:

- o **B-Cell Precursors in BM Receive Signals from BM-Stromal Cells → Triggers B-Cell Development:**
- o **- In Bone Marrow:**
 - **Step 1 – Ig(& BCR)-Gene Rearrangement:**
 - **1. Heavy Chain Rearrangement:**
 - o Random selection of 1xGene from Each of the **V, D & J**–Gene Loci, Then Recombination of these to make a functional gene.
 - **2. Light Chain Rearrangement:**
 - o Random selection of 1xGene from Each of the **V & J**–Gene Loci, Then Recombination of these to make a functional gene.
 - **NB: Important Enzymes Involved:**
 - o **RAG-1 Recombinase**
 - o **RAG-2 Recombinase**
 - o **Ligases**

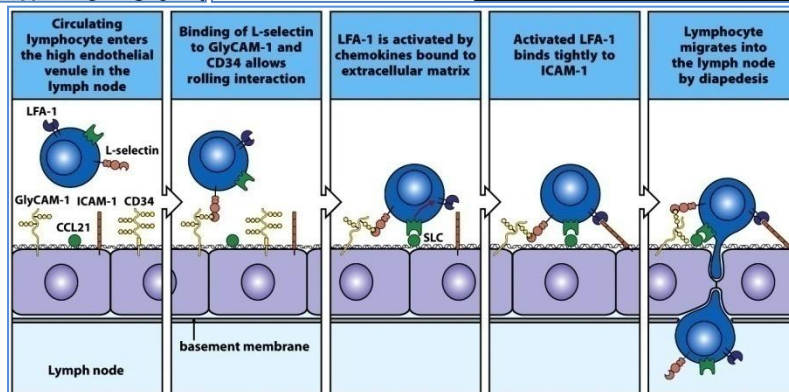
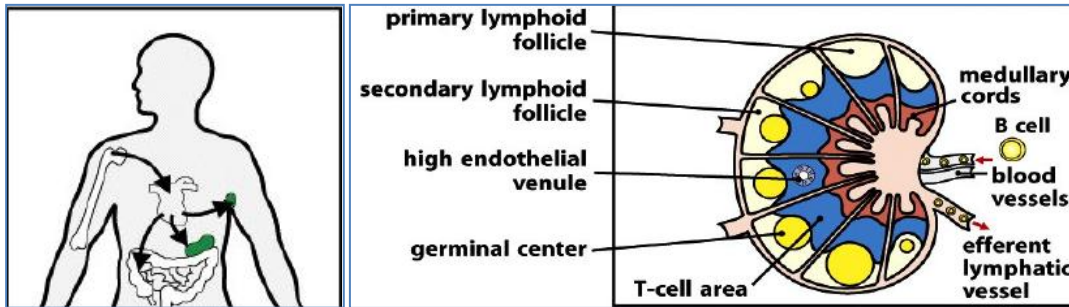


- **Step 2 – IgM & IgD Expression:**
 - Following Ig-Gene Rearrangement, the first BCRs are Expressed on B-Cell Surface.
 - These initial BCRs are IgM and/or IgD.
- **Step 3 – Negative Selection of Autoreactive B-Cells:**
 - BCRs must be tested for Autoreactivity (I.e. Binding to Self-Antigen).
 - B-Cells with Autoreactive BCRs are Negatively-Selected (Removed/Inactivated).



▪ **Step 4 – Migration to Peripheral Lymphoid Organs:**

- Mature, Naive B-Cells leave Bone-Marrow → Migrate to 2° Lymphoid Organs.
- Homing of B-Cells to Follicles is Mediated by Chemokines.
- They Enter *T-Cell Areas* of 2° Lymphoid Organs through *High Endothelial Venules (HEVs)* in a process called *Diapedesis*.
- NB: See section on 'Cell-Adhesion Molecules' for details.
- NB: If B-Cells don't encounter their Specific Ag on their 1st pass, they recirculate.



○ - In 2° Lymphoid Organs (I.e. Lymph Nodes, Spleen, MALT):

▪ **Step 5 – B-Cell Activation (In T-Cell Areas):**

- The Humoral Response is Initiated when Specific Antigen Cross-Links with BCRs.
- Ag. Is Internalised, Processed & Displayed as Peptides on Surface MHC-II Molecules.
- **Antigen-Mediated:**
 - *Thymus Independent Antigens* → Activation Doesn't Require T_H-Cell Help:
 - B-Cell Activation *Without CD4-Helper-T-Cell* Assistance.
 - → B-Cell ACTIVATION...
 - **Th-Cell Mediated:**
 - *Thymus Dependent Antigens* → Activation DOES Require T_H-Cell Help:
 - B-Cell Activation *Requires Th-Cell* Assistance.
 - B-Cell Encounters an Effector T_{H2}-Cell that is Specific to that Ag.
 - B-Cell Activation Requires 3 Signals from Th-Cell:
 - 1) pMHC-II:TCR Interaction
 - 2) CD40_(B-Cell):CD40L_(T-Cell) Interaction
 - 3) Paracrine Secretion of Cytokines onto B-Cells.
 - → B-Cell ACTIVATION...

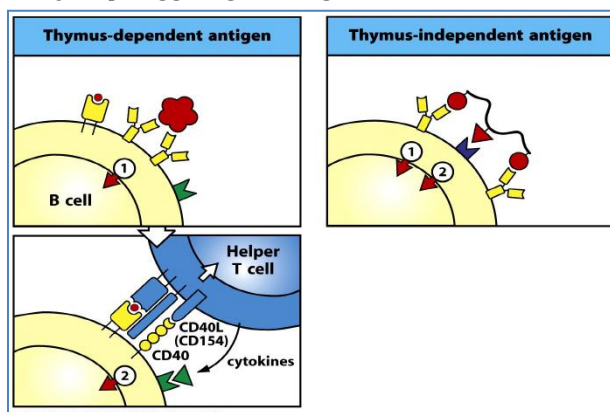
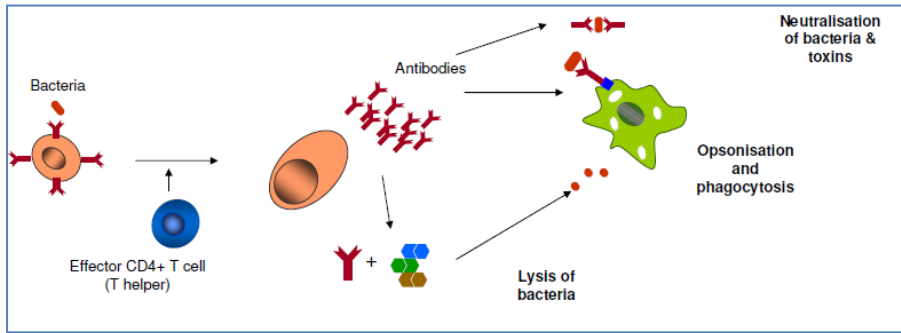
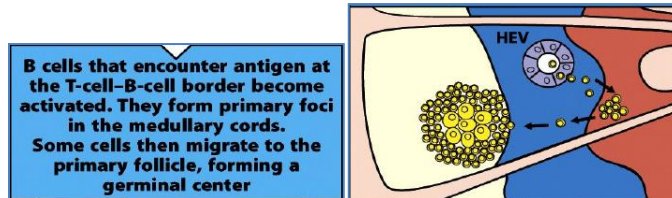


Figure 9-2 Immunobiology, 7ed. © Garland Science 2008

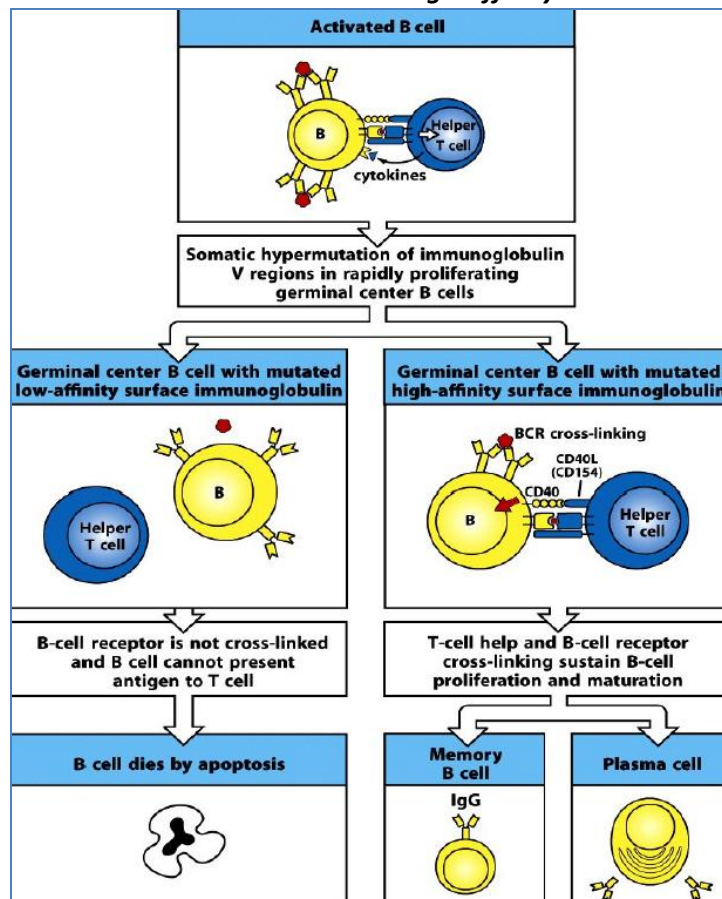


▪ **Step 6 – Differentiation to Plasma Cells (In Germinal Centres):**

- Activated B-Cells Migrate from the T-Cell Areas to the Follicles (B-Cell Areas) & form **Germinal Centres**.
- **Germinal Centres** = Sites of Rapid B-Cell Proliferation & Differentiation.
 - B-Cells differentiate into Ab-Secreting Plasma-Cells (Or Memory B-Cells) in Germinal Centres.
 - Plasma Cells migrate to Medulla, or back to Bone Marrow.
- **NB: During the Process of Differentiation, Secondary Ab-Diversification Mechanisms (Somatic Hypermutation & Isotype Switching) take place.**

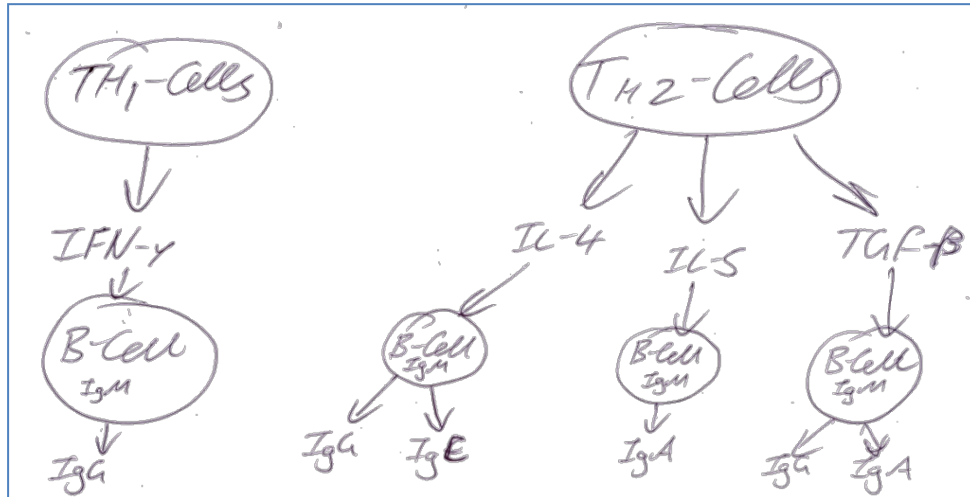


- **Somatic Hypermutation (AKA: Affinity Maturation):**
 - – Single Amino-Acid Mutations are introduced into $V_{(Variable)}$ -Region-Genes.
 - Result = Activated B-Cells with Increased **AND** Decreased Ag-Affinity.
 - **New Ag-Receptors (BCRs) are tested for Increased Ag-Affinity:**
 - Cells with Receptor Mutations that Increase Ag-Affinity → Survive.
 - Cells with Receptor Mutations that Decrease Ag-Affinity → Die.
 - →→ Proliferation of **High-Affinity B-Cells**.



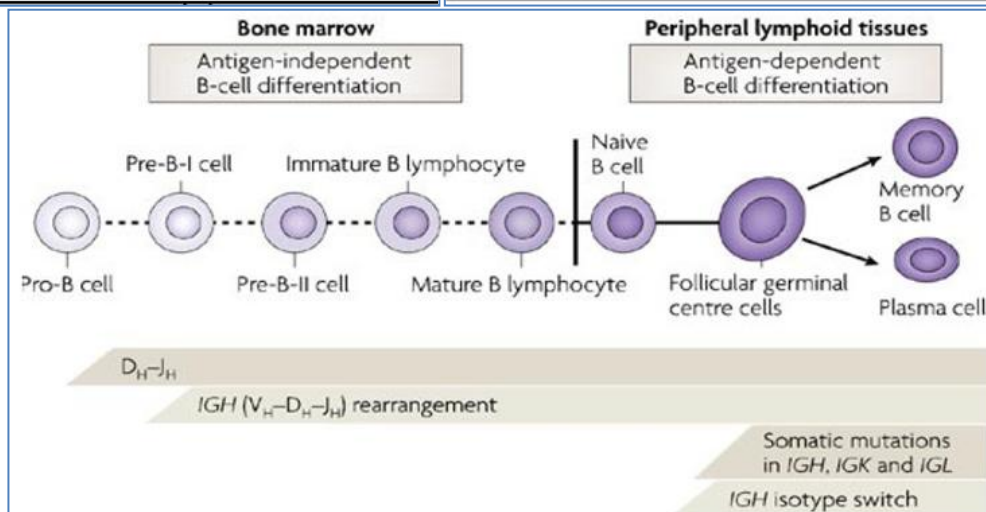
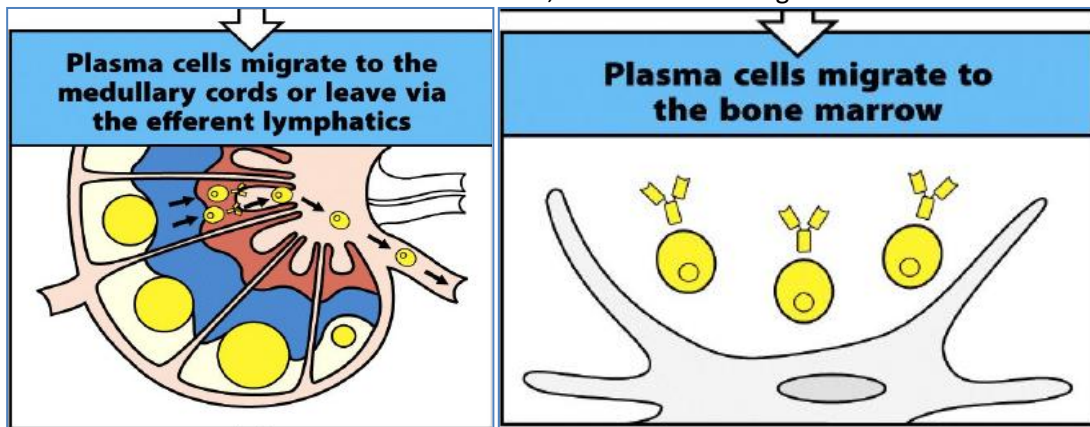
- **Isotype Switching:**

- – F_C Region-Genes of IgM are Replaced with F_C Region-Genes for IgG/IgA/IgE.
- **Requires T_{H1/2}-Cell Help:**
 - **NB:** Cytokines from CD4-T_H-Cells determine which Ab-Class is made.
 - **NB:** It is triggered at the time of B-Cell Activation & hence also Requires CD40_(B-Cell):CD40L_(T-Cell) Interaction
- →→ This change in Ab Constant-Regions → Change in Ab Effector Function.
- **NB:** This doesn't affect Ab-Affinity.
- See 'Isotype Switching' in the Antibody section For Details.



- **Step 7 – Ab-Secretion:**

- Plasma Cells are activated, differentiated Long-Lived B-Cells that secrete Antibodies.



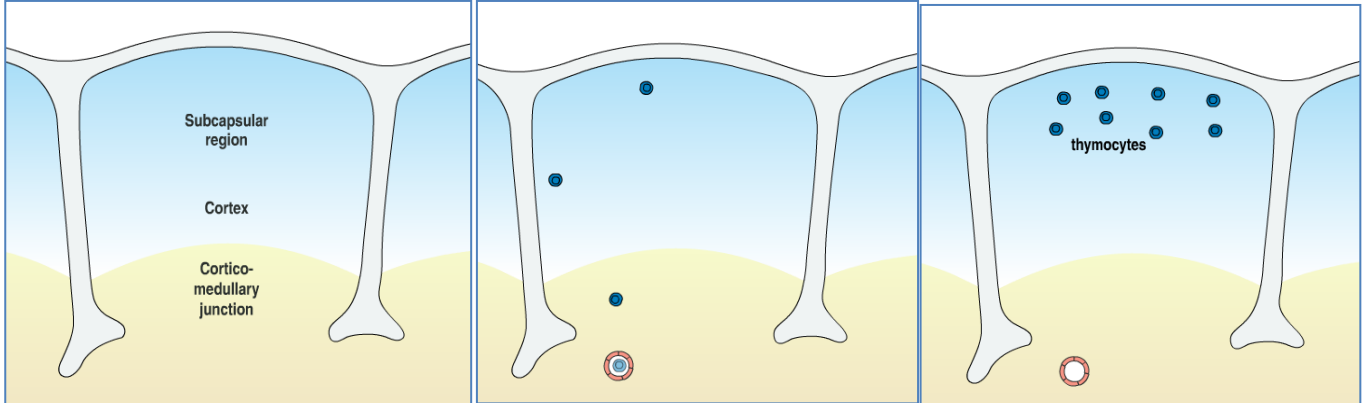
Above: Simplified Summary of the B-Cell Development

- T-Cell Development:

○ **- In The Thymus:**

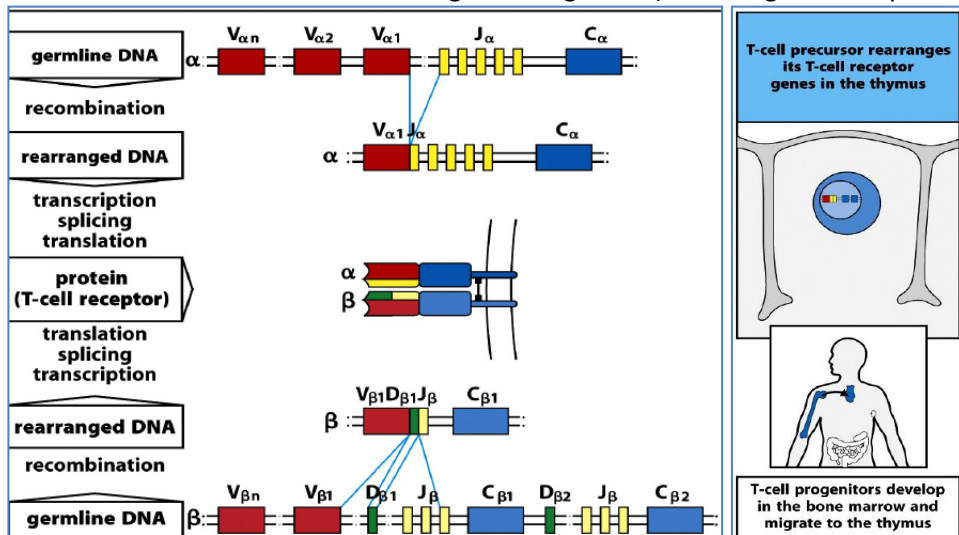
▪ **Step 1 – Double Negative Thymocytes Enter Thymus:**

- During Embryogenesis, Immature, 'Double-Negative' Thymocytes Enter the Thymus via High Endothelial Venules in the *Cortico-Medullary Junction*.
 - **NB: 'Double-Negative'** = Expresses *Neither CD4 or CD8*.
- They then Migrate to the **Sub-Capsular Region** of the Thymus, where they begin TCR-Gene Rearrangement.

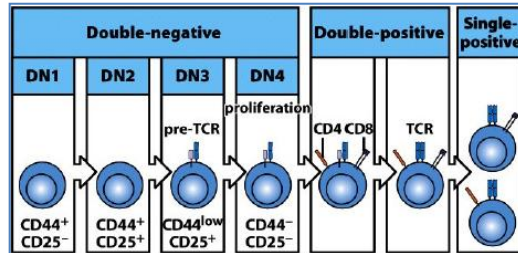


▪ **Step 2 – TCR-Gene Rearrangement:**

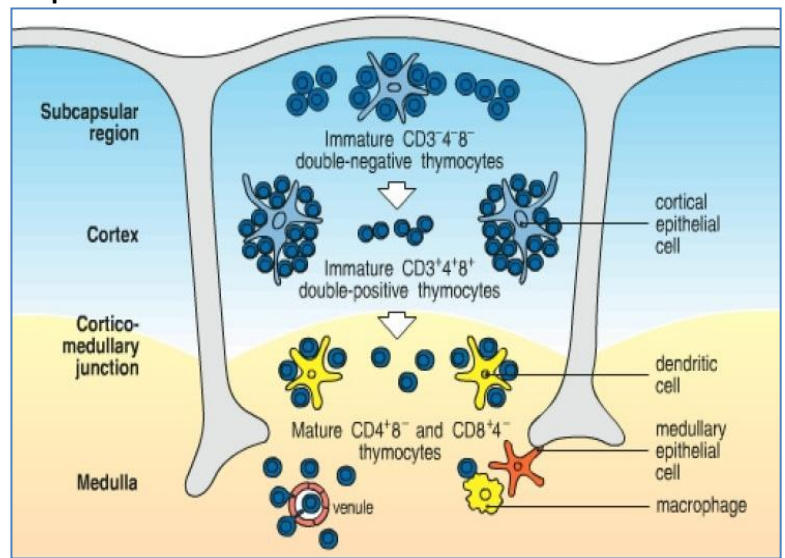
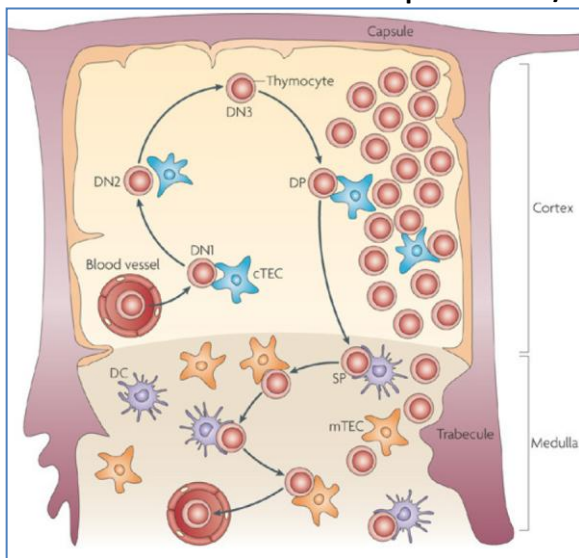
- **1st: β (or δ)-Chain Gene Rearrangement:**
 - Random selection of 1xGene from Each of the **V, D & J** –Gene Loci, Then Recombination of these to make a functional gene.
- **2nd: α (or γ)-Chain Gene Rearrangement:**
 - Random selection of 1xGene from Each of the **V & J** –Gene Loci, Then Recombination of these to make a functional gene.
 - **NB: 2 Possible T-Cell 'Lineages'; Depending whether ' $\alpha\beta$ ' or ' $\gamma\delta$ ' TCRs:**
 - * **$\alpha\beta$ T-Cells Predominate** →
 - CD4 (helper & regulatory)
 - or CD8 T-Cells.
 - **$\gamma\delta$ T-Cells = Minority** → Mimic cells of the Innate Immune System →
 - Reside in Lymphoid & Epithelial Tissues (Skin/Repro/GIT)
 - **Recognise Whole Antigen** (as opposed to $\alpha\beta$ T-Cells)
- **(NB: Important Enzymes Involved)**
 - RAG-1 Recombinase
 - RAG-2 Recombinase
 - Ligases
- **Outcome:** Each TCR has a Different Sequence (Due to different Gene-Fragments & Errors Introduced during Rearrangement) → Recognise Many Different Foreign Ags.



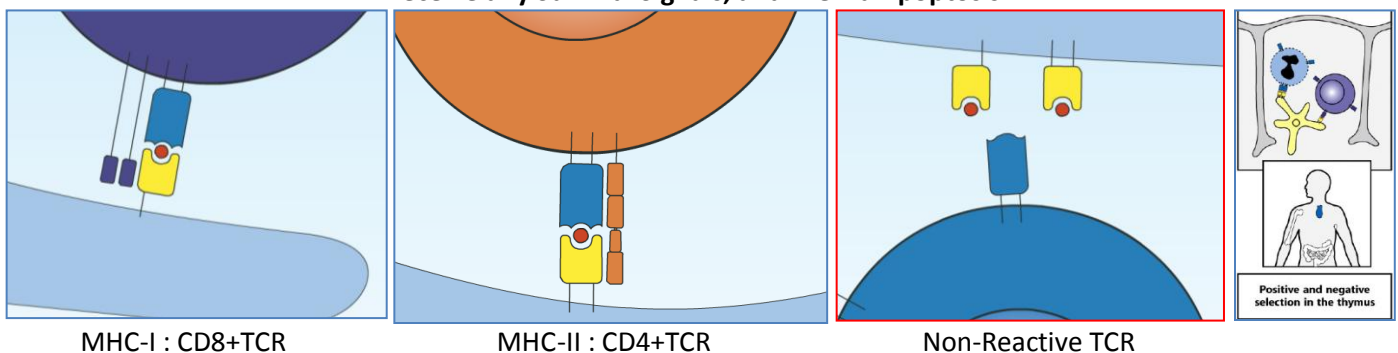
- **Step 3 – TCR Expression:**
 - Thymocytes then express their specific TCRs (**dictated by genes**) on their Membrane.
- **Step 4 – Differentiation into *Double Positive* Thymocytes:**
 - Double Negative Thymocytes Proliferate & Differentiate into *Double Positive* Thymocytes.
 - Ie. They Express **Both CD4, & CD8** Surface Molecules.
 - They then Migrate into the **Cortico-Medullary Junction**.



- **Step 5 - Positive Selection (Thymic Cortex):**
 - **Thymic APCs (Cortical Epithelial Cells, Dendritic Cells & Macrophages)** display **Peptide:MHC-I/II Complexes** on their Membranes.

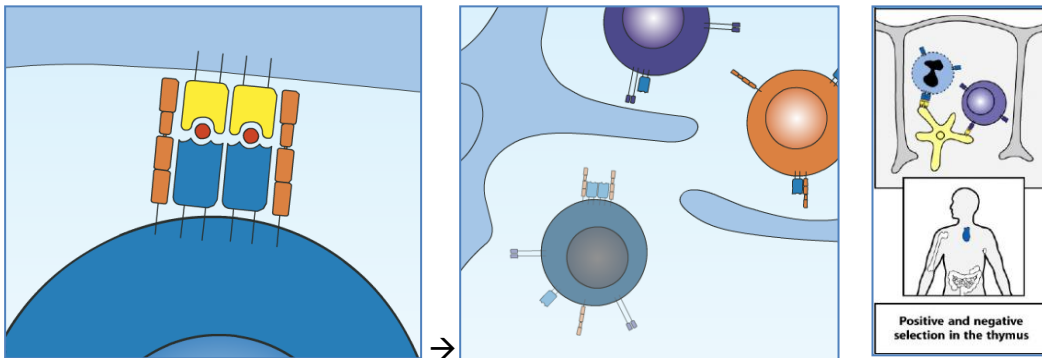


- **These pMHC-I/II Complexes may be recognised by TCRs on the Thymocytes.**
 - **Thymocytes with TCRs able to bind pMHC-I Complexes → Receive:**
 - 1. A Survival Signal
 - 2. A Maturation Signal
 - - Eventually, it stops Expressing CD4 & Maintains Expressing CD8 → **Becomes CD8 T-Cell.**
 - **Thymocytes with TCRs able to bind pMHC-II Complexes → Receive:**
 - 1. A Survival Signal
 - 2. A Different Maturation Signal
 - - Eventually, it stops Expressing CD8 & Maintains Expressing CD4 → **Becomes CD4 T-Cell.**
- **NB: Cells with TCRs that are Unable to Recognise *Either* MHC-I or MHC-II, Fail to Receive any Survival Signals, and Die via Apoptosis.**



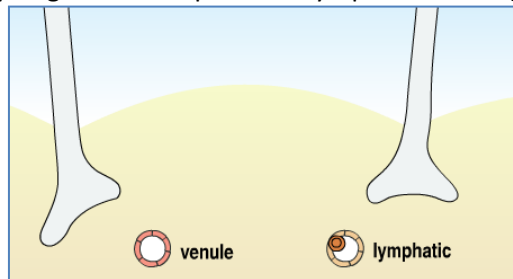
▪ **Step 6 – Negative Selection (Medulla):**

- CD4 & CD8 Thymocytes move into the Medulla where they encounter more APCs.
- **Thymocytes with TCRs that bind pMHC-I/II Too Avidly Receive a Strong Signal that Drives them into Apoptosis.**
 - This eliminates Thymocytes capable of responding to Self-Peptide Antigens.
 - This is Essential for **Central Tolerance**.



▪ **Step 7 – Mature Naive CD4/CD8-T-Cells Leave the Thymus:**

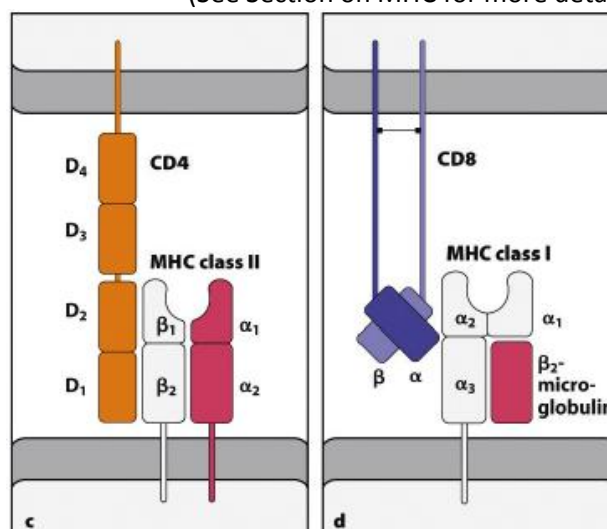
- Naive Single-Positive CD4/CD8-T-Cells Leave the Thymus via Venules/Lymphatics.
- They Migrate to Peripheral 2^oLymphoid Tissue (Spleen/Lymph-Nodes/MALT)



○ **– In the Periphery (Peripheral 2^oLymphoid Organs)**

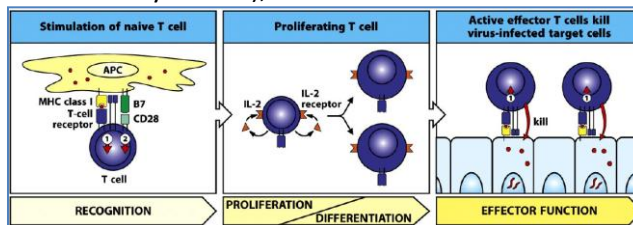
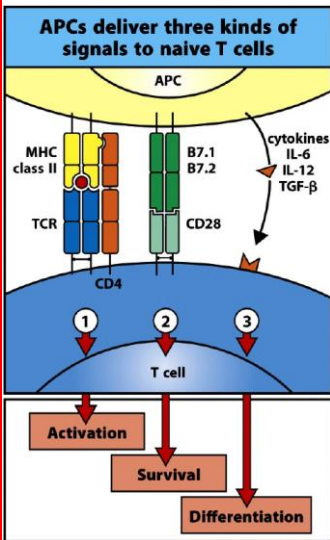
▪ **Step 8 – Antigen Recognition:**

- **MHCs on APCs Present Specific Ag-Peptide to Respective TCRs on Naive T-Cells:**
 - TCRs on **CD4-T-Cells** Recognise their Specific **Peptide:MHC-II** Complexes
 - (Because CD4 has Specific Binding Sites for MHC-II)
 - TCRs on **CD8-T-Cells** Recognise their Specific **Peptide:MHC-I** Complexes
 - (Because CD8 has Specific Binding Sites for MHC-I)
 - **NB:** T-Cells do NOT recognise whole antigen (as opposed to B-Cells)
 - **NB:** T-Cells do NOT recognise any peptide which isn't bound to MHC.
 - However, **Superantigens** can bind TCR+MHC *Without Processing*.
(See Section on MHC for more detail)



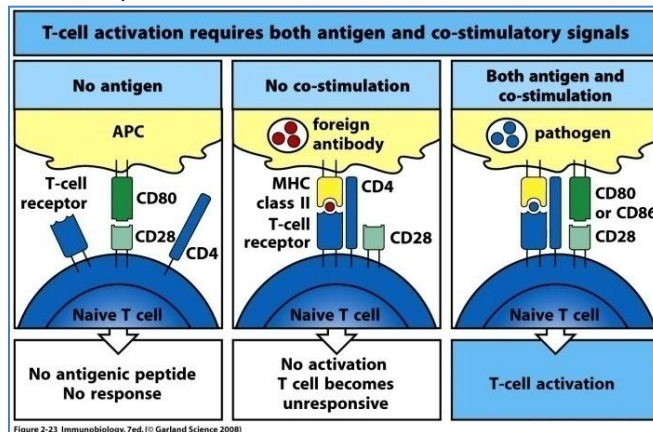
▪ **Step 9 – T-Cell Activation (Proliferation & Differentiation):**

- **NB: T-Cells Require 3 Kinds of Signals From APCs in order to be fully Activated:**
 - **1. Activation Signal**
 - **2. Survival Signal (AKA: CO-STIMULATORY SIGNAL)**
 - **3. Differentiation/Proliferation Signal**
- **1. Activation Signal – Via TCR Binding to pMHC-I or pMHC-II:**
 - MHC-I:
 - (For Binding with TCRs & CD8 Molecules on CD8-T-Cells)
 - MHC-II:
 - (For Binding with TCRs & CD4 Molecules on CD4-T-Cells)
- **2. Survival Signal – CD28/CD40 Binding to Co-Stimulator Molecules:**
 - CD80 (aka. 'B7'):
 - (For Binding with **CD28** on CD8/CD4 T-Cells)
 - **NB: Binding of CD28 to either CD80 or CD86 → Triggers Cell Cycle & Induces IL-2 Synthesis → Drives T-Cell Proliferation.**
 - CD86:
 - (For Binding with **CD28** on CD4 T-Cells)
 - **NB: Binding of CD28 to either CD80 or CD86 → Triggers Cell Cycle & Induces IL-2 Synthesis → Drives T-Cell Proliferation.**
 - CD40:
 - (For Binding with **CD40-Ligand** on CD4 T-Cells)
 - 4-1BB Ligand:
 - (For Binding with 4-1BB on CD8 T-Cells)
 - **NB: Proliferation Signal: CD28-Induced IL-2 → Drives T-Cell Proliferation**
- **3. Differentiation Signal – Via Cytokines:**
 - **From APCs - See Table**
 - **From Other Innate Immune Cells - Full T-Cell Activation requires Cytokines from the Innate Immune system, to become fully activated. (Therefore, non-infective Ags, which don't stimulate the Innate Immune System (or release of cytokines), WILL NOT activate T-Cells. → Tolerance)**



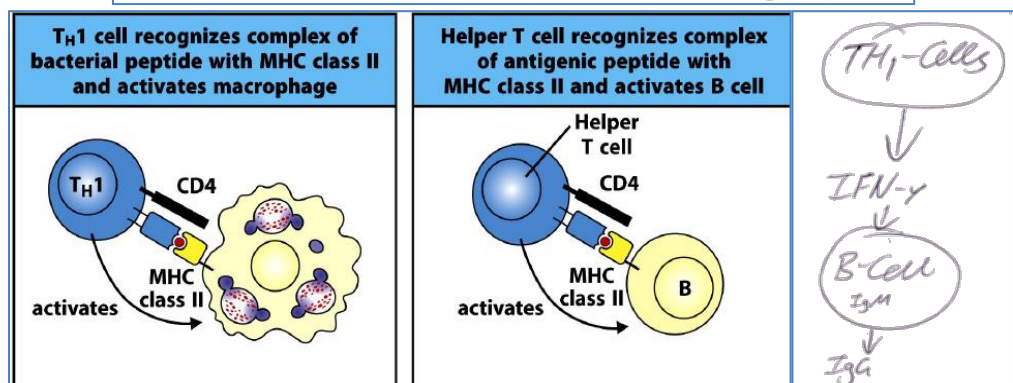
Role of Signal	APC-Surface Molecules	BINDING PARTNERS	
		On CD4 T-Cells	On CD8 T-Cells
1. Activation (Ag Recognition)	MHC-I MHC-II	- Specific TCR & CD4	Specific TCR & CD8 -
2. Survival (Co-Stimulatory Molecules)	CD80 ("B7.1") CD86 ("B7.2") CD40 4-1BB-Ligand	CD28 CD28 CD40-Ligand -	CD28 - - 4-1BB
(2. Survival Continued..) (Via a Cytokine)	IL-2	IL-2 _{Receptor}	IL-2 _{Receptor}
3. Differentiation (Cytokines)	TGF-β IL-6 IL-12 → Th1 IFNγ → Th1 IL-4 → Th2 IL-2	Signal 3 delivered by antigen-presenting cell 	
		→ Differentiation of CD8-T-Cells → Cytotoxic NB: Most CD8-T-Cell Diff. Requires CD4 Help; but can occur Independently if Stimuli is Strong Enough.	

- **NB: Binding of any of these APC-Surface-Molecules to their respective partners on T-Cells → Activates Intracellular Domains of both APC- & T-Cell- Surface-Molecules.**
 - → Activates Intracellular Signalling Cascades → Altered Gene Expression
 - → Altered Gene Expression → Differentiation →
 - Effector Cells
 - OR Memory Cells
- **NB: TCR:Ag Recognition *Alone*, or Co-Stimulation *Alone* Is NOT ENOUGH to Activate T-Cells; and Can Inactivate the Reactive T-Cells → Tolerance.**
 - **NB: This is a good safeguard in preventing activation of Auto-Reactive T-Cells (See Section on MHC & Central Tolerance for more details)**



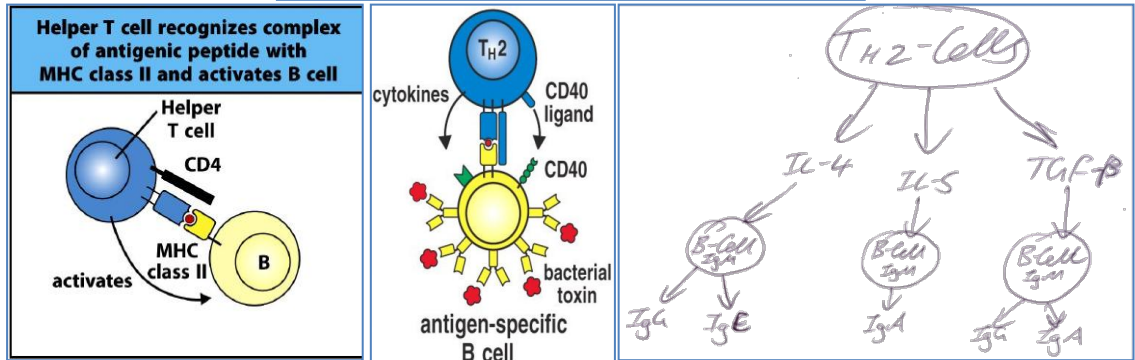
▪ **Step 10 – Effector Functions:**

- **NB: Effector Functions depend largely on the Cytokines that they produce.**
- **CD4-Helper-T-Cells: - Function to Activate Other Cells:**
 - Recognise Bacterial/Antigenic Peptide Presented on MHC-II
 - **Th1-Helper T-Cells: (Recognise *Bacterial* Peptide)**
 - Activate Macrophages (**Via IFN γ & CD40L**) → More Cytotoxic
 - Induces T-Cell Proliferation (**Via IL-2**)
 - Help B-Cells → *Switch* IgM-Plasma-B-Cells → Secrete IgG. (**Via IFN γ**)
 - **Cytokines & Effector Functions:**

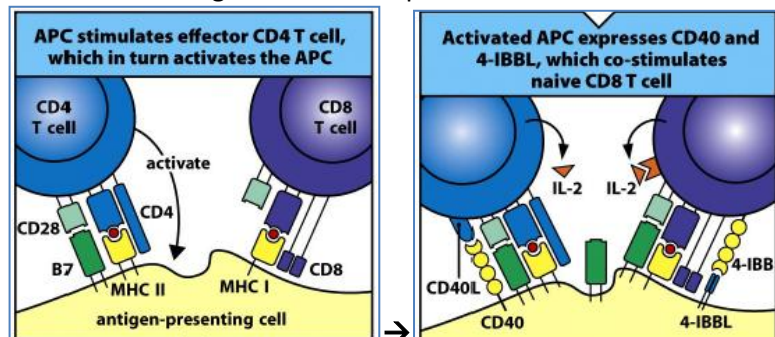


- **Th2-Helper T-Cells:** (Recognise Antigenic Peptide)
 - Help B-Cells → Switch IgM-Plasma-B-Cells → Secrete IgG/E/A.
(Via IL-4, IL-5 & TGF-β; AND Co-Stimulation from CD40:CD40L)
 - **Cytokines & Effector Functions:**

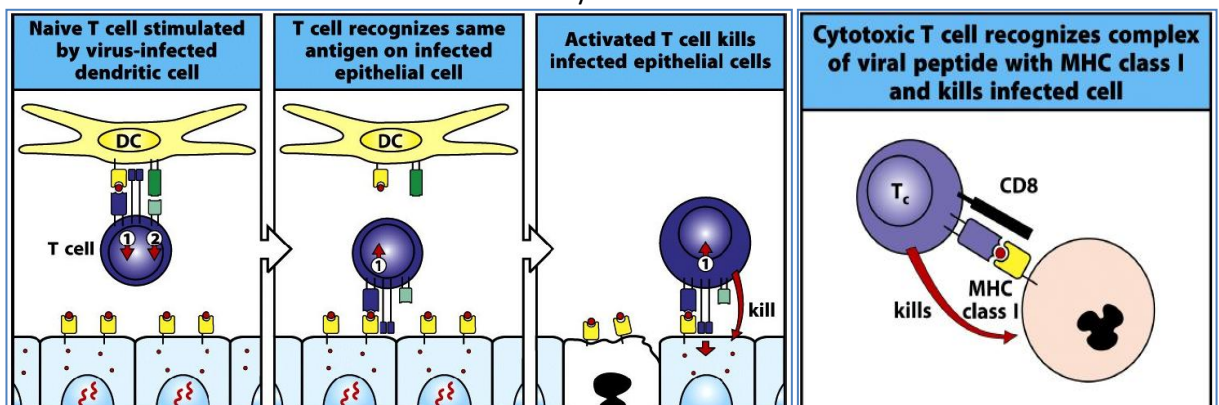
Type 2:	IL-4	➔	<ul style="list-style-type: none"> • Humoral responses • Helminth immunity • Allergy
	IL-5		
	IL-6		
	IL-10		
	IL-13		



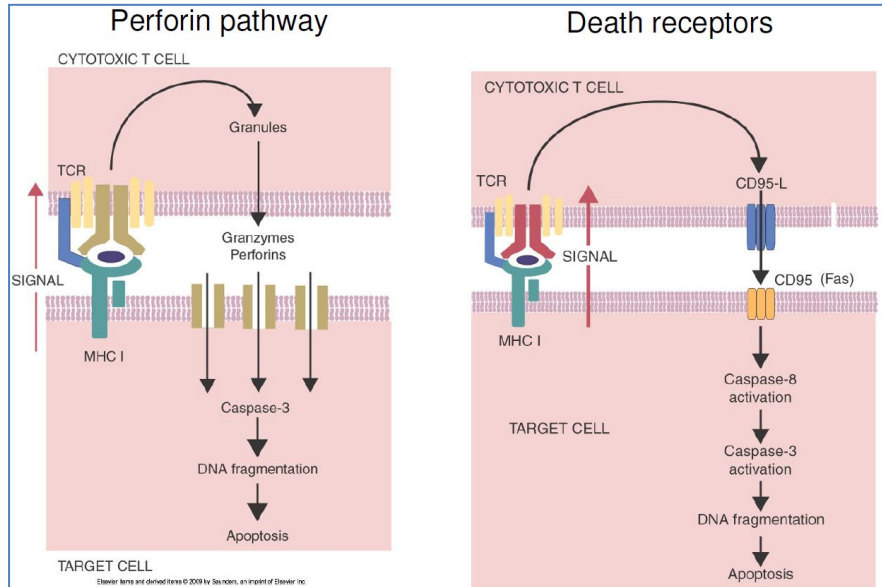
- **(Th17-Helper T-Cells):**
 - Recruit Neutrophils (Via IL-17)
- **(T-Regulatory Cells):**
 - Suppress T-Cell Function (Via IL-10 & TGF-β)
- **CD8-Cytotoxic-T-Cells: - Function to Eliminate Infected/Abnormal Cells:**
 - **NB:** Help from Th-Cells is Usually Essential for:
 - Differentiation into Cytotoxic T-Cells (Via IFN γ)
 - Enhancing CD8-T-Cell Responses.



- **Directly Kill Cells Displaying Viral Peptides bound to MHC-I.**
 - **NB:**CTLs also release Cytokines:
 - IFN γ → Inhibits Viral Replication
 - TNF α → Pro-Inflammatory
 - Also can destroy Tumour Cells

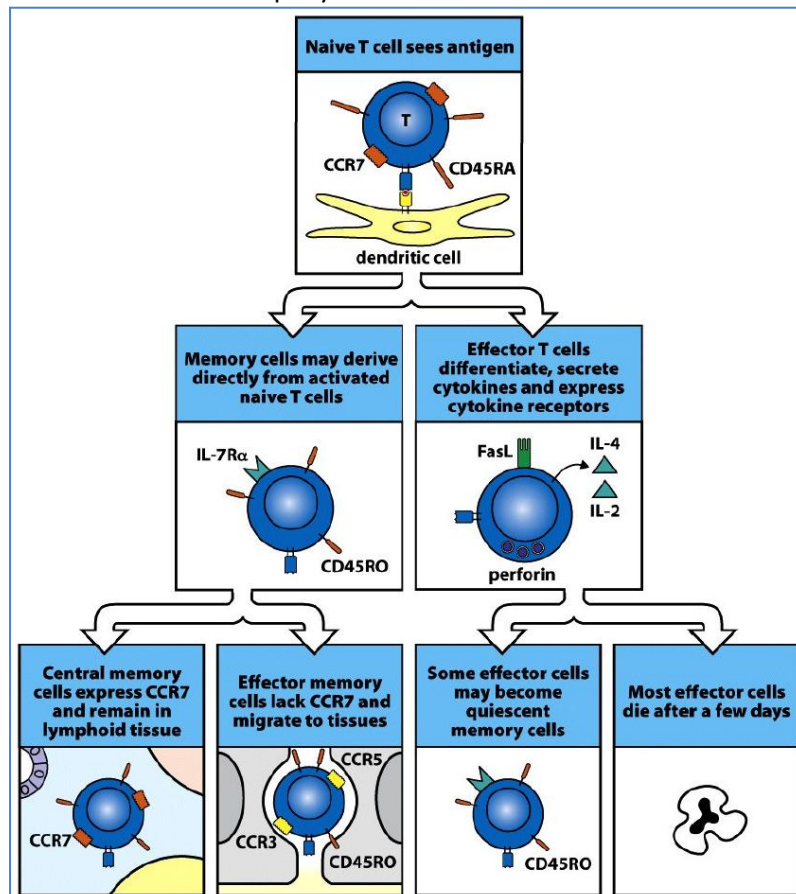


- **CD8 Cells Kill by *Release of Cytotoxic Granules* → Induce Apoptosis:**
 - Perforin – Aids in delivering Granzymes/Granulysin into Cell.
 - Granzymes
 - Granulysin
- **The above Chemicals cause Apoptosis by Either:**
 - Causing Release of Cytochrome-C from Mitochondria &/Or Caspases → Induces DNA Damage → Apoptosis.
 - Or by Activating '*Death Receptors*' (Eg. Fas).

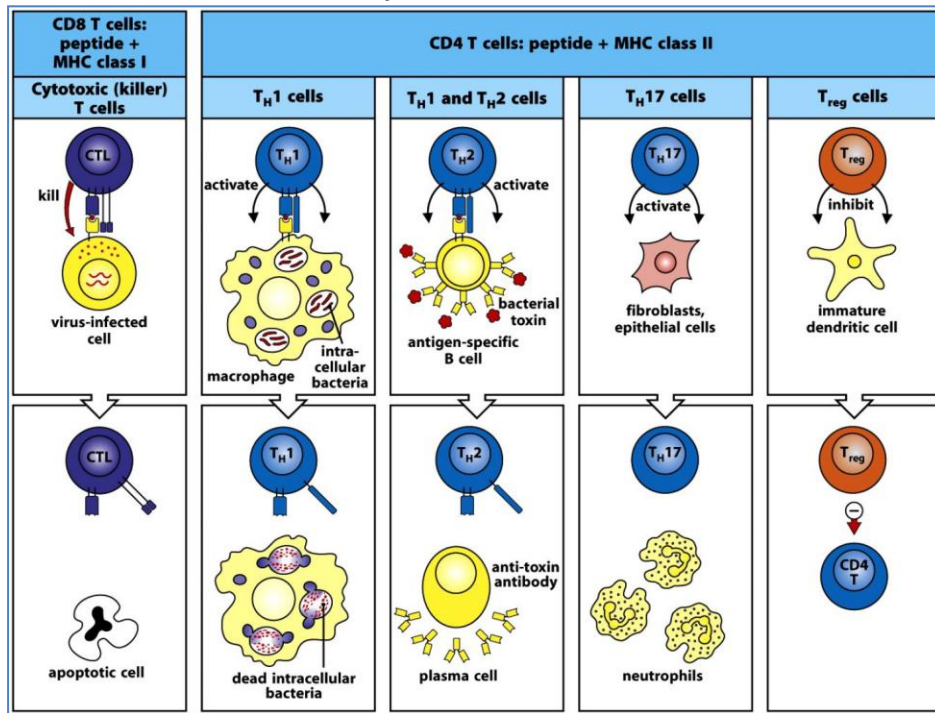


- **Memory T-Cells:**

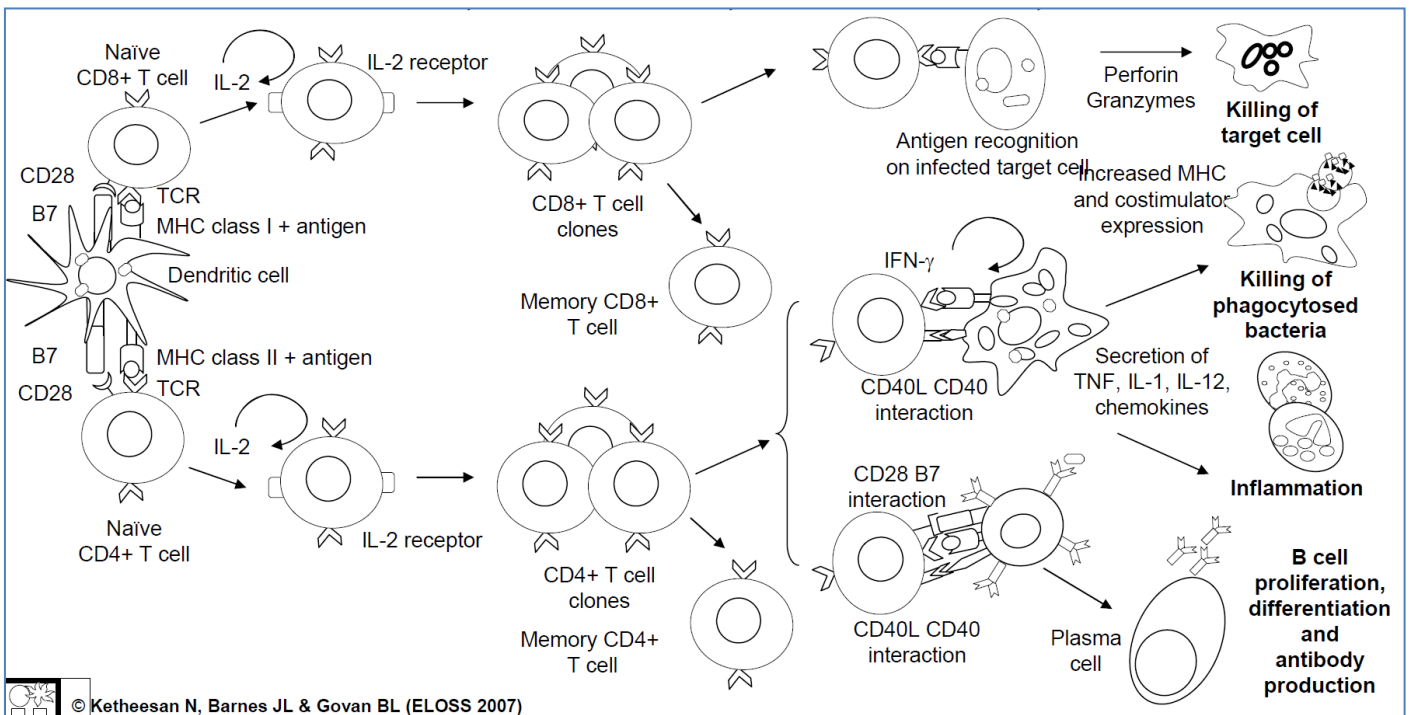
- Those that don't become Effector Cells, become Memory Cells.
- They are *Long-Lived* & Persist @ Higher Levels than Naive Lymphocytes.
- Respond Rapidly to Ag-Challenge.
- Can Rapidly Differentiate into Effector Cells.



Summary of T-Cells & Functions:



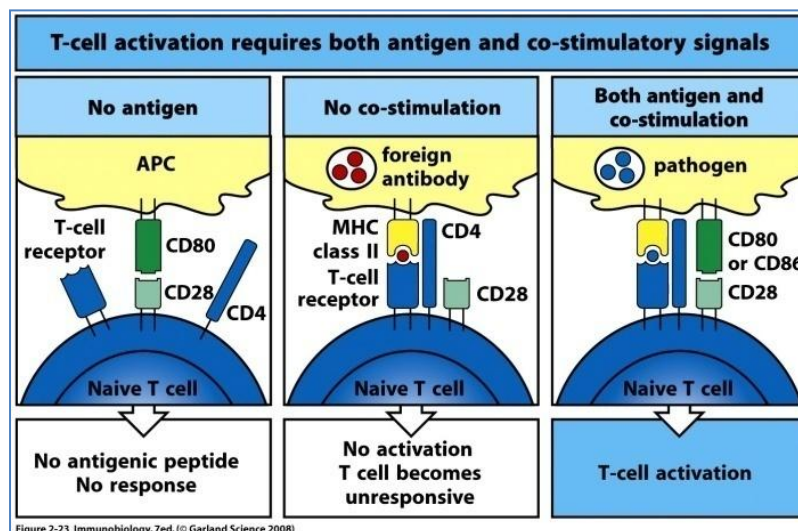
Pathogens targeted	Viruses (e.g. influenza, rabies, vaccinia) Some intracellular bacteria	Microbes that persist in macrophage vesicles (e.g. mycobacteria, <i>Listeria</i> , <i>Leishmania donovani</i> , <i>Pneumocystis carinii</i>) Extracellular bacteria	Helminth parasites	Extracellular bacteria (e.g. <i>Salmonella enterica</i>)



© Ketheesan N, Barnes JL & Govan BL (ELOSS 2007)

“Tolerance”:

- **What is it?**
 - “The state of *Immunological Unresponsiveness* of the *Lymphoid Tissue* to a *Specific Antigen*”
 - **NB: Tolerated Antigens = “Tolerogens”**
- **Why is it important?**
 - Important in preventing *Autoimmunity*.
- **How is it achieved?**
 - **1. SELF-TOLERANCE (“CENTRAL TOLERANCE”):**
 - **Negative Selection of B-Cells & T-Cells in Primary Lymphoid Organs:**
 - Lymphocytes Reactive to Self-Ags are Clonally Deleted during development.
 - **NB:** However, it is impossible to expose all T-Cells to *every Self-Ag* since many of them aren’t expressed in the Thymus. (See below for fail-safes)
 - **Fail-safes:**
 - B-Cells escaping negative selection require T_H-Cell Help to produce antibody.
 - T-Cells escaping negative selection are regulated by *other cells* in periphery.
 - **2. ACQUIRED IMMUNOLOGICAL TOLERANCE (“PERIPHERAL TOLERANCE”):**
 - **A) - TCR:Ag Recognition *Alone*, or Co-Stimulation *Alone* Is NOT ENOUGH to Activate T-Cells; and Can Inactivate the Reactive T-Cells → Tolerance.**
 - **NB:**This is a good safeguard in preventing activation of Auto-Reactive T-Cells.
 - **B) – Exposure to Exogenous Non-Inflammatory Antigens (eg. Dust/Pollen/Food) can → Tolerance:**
 - Full T-Cell Activation requires Cytokines from the Innate Immune system to become fully activated.
 - Therefore, non-infective Ags, which don’t stimulate the Innate Immune System (or release of cytokines), WILL NOT activate T-Cells. → Tolerance



Functional Anatomy of the Important Secondary Lymphoid Organs:

Lymph Nodes: The *only* Filters of the Lymphatic System: - They Filter out Lymph-Borne Foreign Antigens, & help activate the immune system.

- **3 Regions:**
 - **1. Cortex –**
 - **Outer Cortex –** Mostly B-Cells organised into '**Lymphoid Follicles**' with '**Germinal Centers**' of heavily dividing B-Cells. These Lymphoid Follicles are encapsulated by Dendritic Cells.
(NB: During an infection, it is these Germinal Centres of proliferating B-Cells that cause the lymph node to expand.)
 - **2. Paracortex –** Mostly circulating T-Cells.
 - **3. Medulla –** (As defined by **Medullary Cords**) Contains Plasma Cells, Macrophages, & B+T-Cells
 - **The Reticular Network** - Fine networks of macrophage-lined reticular fibres that form the main structural support substance of the Lymph Node, as well as provide a surface for adhesion of Dendritic Cells, Macrophages & Lymphocytes, between Lymphoid Follicles & Medullary Cords.
- **Dendritic Cells & Macrophages are the Antigen Presenting Cells** in Lymph Nodes.
- **Circulation in a Lymph Node:**
 - Lymph enters the convex side of a lymph node via numerous **Afferent Lymphatic Vessels**, carrying with it active Antigen-Presenting Cells such as Dendritic Cells, as well as free antigen. (NB: Lymphocytes enter from the blood via HEVs)
 - It then percolates through the **Lymph Sinuses**, the areas of the Reticular Network surrounding the Lymphoid Follicles & Medullary Cords, where Dendritic Cells present their antigens to the surrounding T-Cells, & foreign particles are trapped by Macrophages.
 - The Lymph Sinuses then converge at the **Hilum** & lymph exits the node via the **Efferent Lymphatic Vessels**, towards either a more central Lymph Node or into the Blood.
- **Mechanism of Immune Function:**
 0. Antigen-Bearing Dendritic Cells & free Antigens enter the Lymph Node via Afferent Lymphatic Vessels. (NB: the dendritic cells actively migrate to the lymph node due to Chemokines.)
 1. Naive B & T-Lymphocytes are also attracted by chemokines to the Lymph Node, and enter via High Endothelial Venules located in the Paracortical Area (T-Cell zone).
 2. Because the above cells are attracted to the Node via Chemokines, they all tend to become localised together in the Paracortical Areas.
 3. Dendritic Cells then present antigens to their respective Naive T-Cells, which proliferate and mature into Effector Cells capable of activating their respective Naive B-Cells.
 4. Effector T-Cells then subsequently activate their respective B-Cells, causing them to proliferate and migrate into nearby Germinal Centres, where they continue to rapidly proliferate.
 5. Effector B-Cells differentiate into plasma cells & begin secreting Ab's. During this time Effector B-Cells undergo a process of selection where their receptors are tested for their ability to bind antigen. (Those that fail, will die)
 6. Ab's & Effector T-Cells leave the lymph node via Efferent Lymphatics & travel via the blood to the site of infection where inflammatory mediators have activated vascular endothelial cells → expression of Adhesion Molecules.
 7. At the site of infection:
 - CD4-T-Cells Activate Macrophages to make them more cytotoxic.
 - Antibodies bind to Antigens & recruit complement to: a) Lyse bacteria directly, or b) Opsonize them to enhance their phagocytosis.
 - In the case of a Viral Infection, activated CD8-T-Cells would kill any infected cells present.
- **NB: Lymph Nodes are Important sites for Immunoglobulin Isotype Switching** (or Class Switching), a mechanism that changes a B-Cell's production of Antibody from one class to another. Eg. From IgM to IgG. NB: This process does not affect Antigen Specificity & the Antigen retains Affinity for the same Antigens, but it can now interact with different effector molecules.

A lymph node

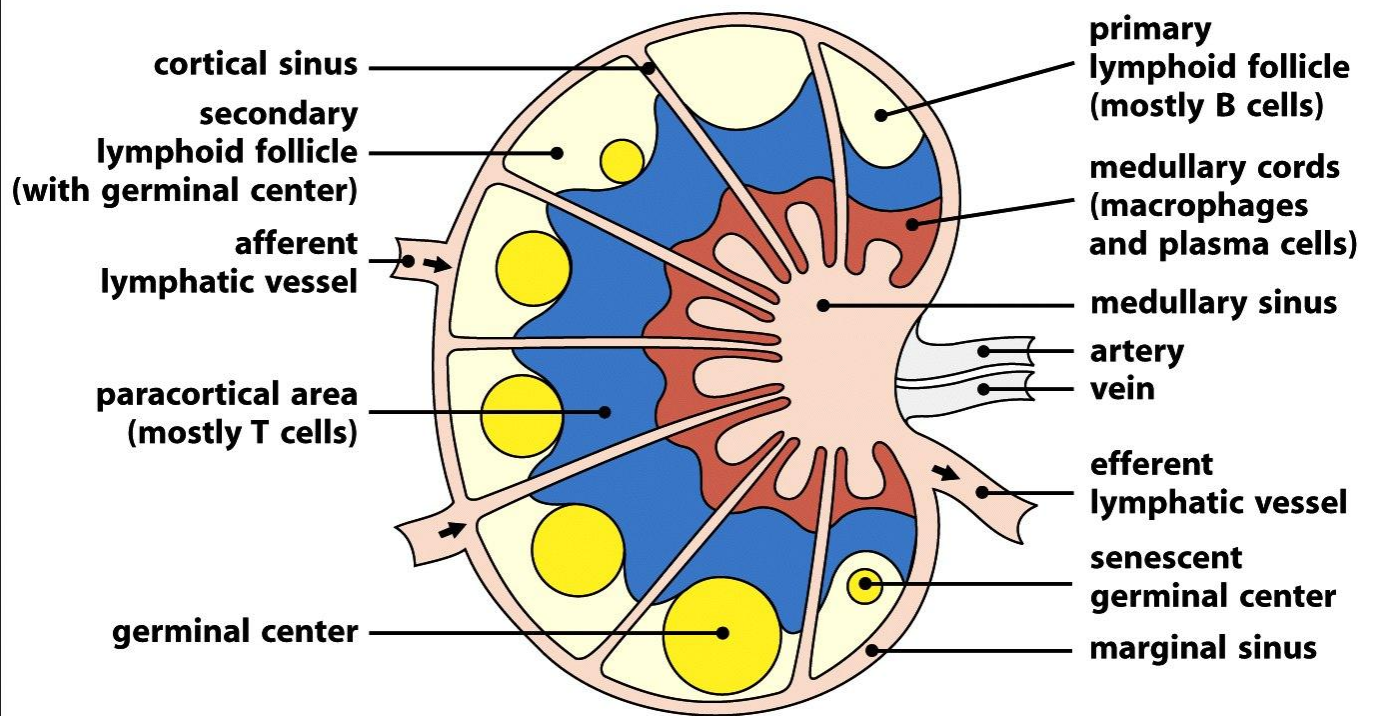
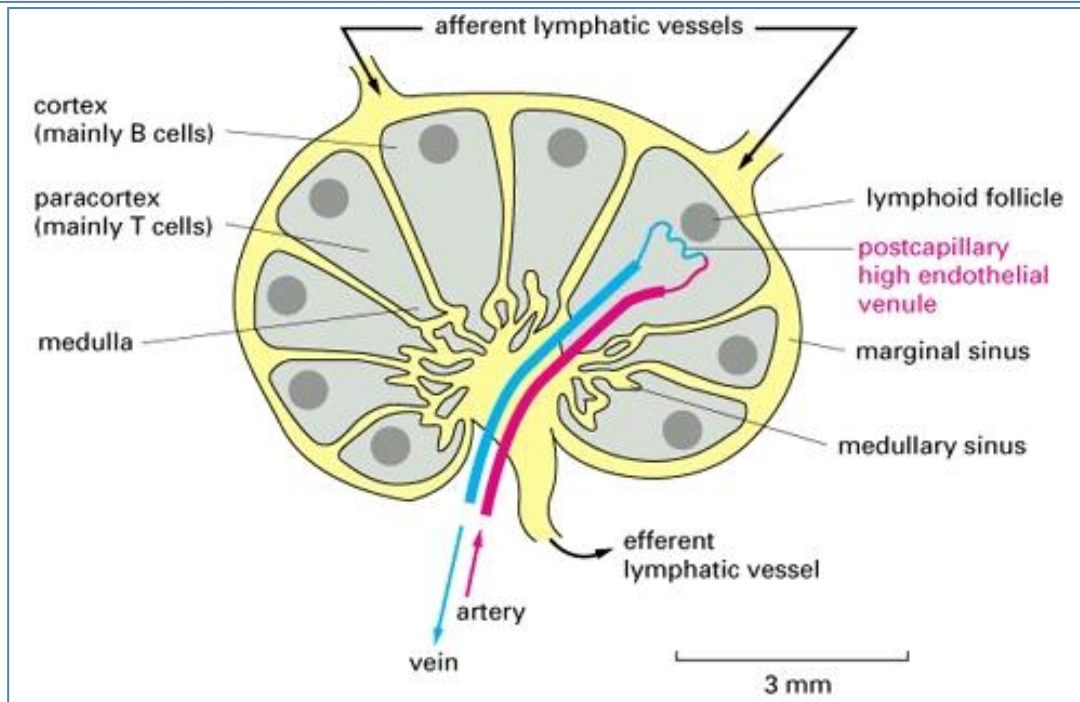


Figure 1-18 part 1 of 2 Immunobiology, 7ed. (© Garland Science 2008)



Spleen: The Filter of the Circulatory System – It is the largest lymphoid organ,

Functions:

- It Filters out Foreign **Blood-Borne Antigens**
- Filters out **dying RBCs & Platelets** from the Blood (& stores some RBC breakdown products – eg. Iron from Hb - & releases others to the blood for liver processing).
- **Stores blood Platelets**
- Providing a site for **Lymphocyte Proliferation, Immune Surveillance & Immune Response.** (Contains B+T-Lymphocytes & Macrophages)

Anatomy:

- Fibrous capsule with Trabeculae extending inward
- Contains B+T-Lymphocytes & Macrophages, as well as huge #s of Erythrocytes (RBCs)
 - **White Pulp:** Clusters of **B- & T-Lymphocytes**, suspended on Reticular Fibres, which surround the afferent Arterioles. White pulp is divided into 3 areas:
 - **Periarteriolar Lymphoid Sheath (PALS)** - containing mainly T-Cells
 - **Lymphoid Follicles** (mainly B-Cells)
 - **Germinal Centre** – heavily dividing B-Cells
 - **B-Cell Corona** – B-Cells
 - **Marginal Zone** – Surrounds the Follicles (Rich in Macrophages; Some T-Cells; Some non-circulating B-Cells called Marginal Zone B-Cells)
 - **Perifollicular Zone:** Zone surrounding both the Marginal Zone of the Follicles & the Periarteriolar Lymphoid Sheath. Blood-borne Cells & Antigen enter splenic tissue here.
 - **Red Pulp:** All remaining Splenic Tissue – Composed of Connective Tissue, Venous Sinuses & Splenic Cords. Its primary function is to filter the blood of defective RBCs, Antigens & Microorganisms.
(Rich in Macrophages, RBCs, Granulocytes & Platelets)
 - **Venous Sinuses:** Blood Sinusoids
 - **Splenic Cords:** Regions of Reticular Conn.Tissue exceptionally Rich in Macrophages.

Blood Flow through the Spleen:

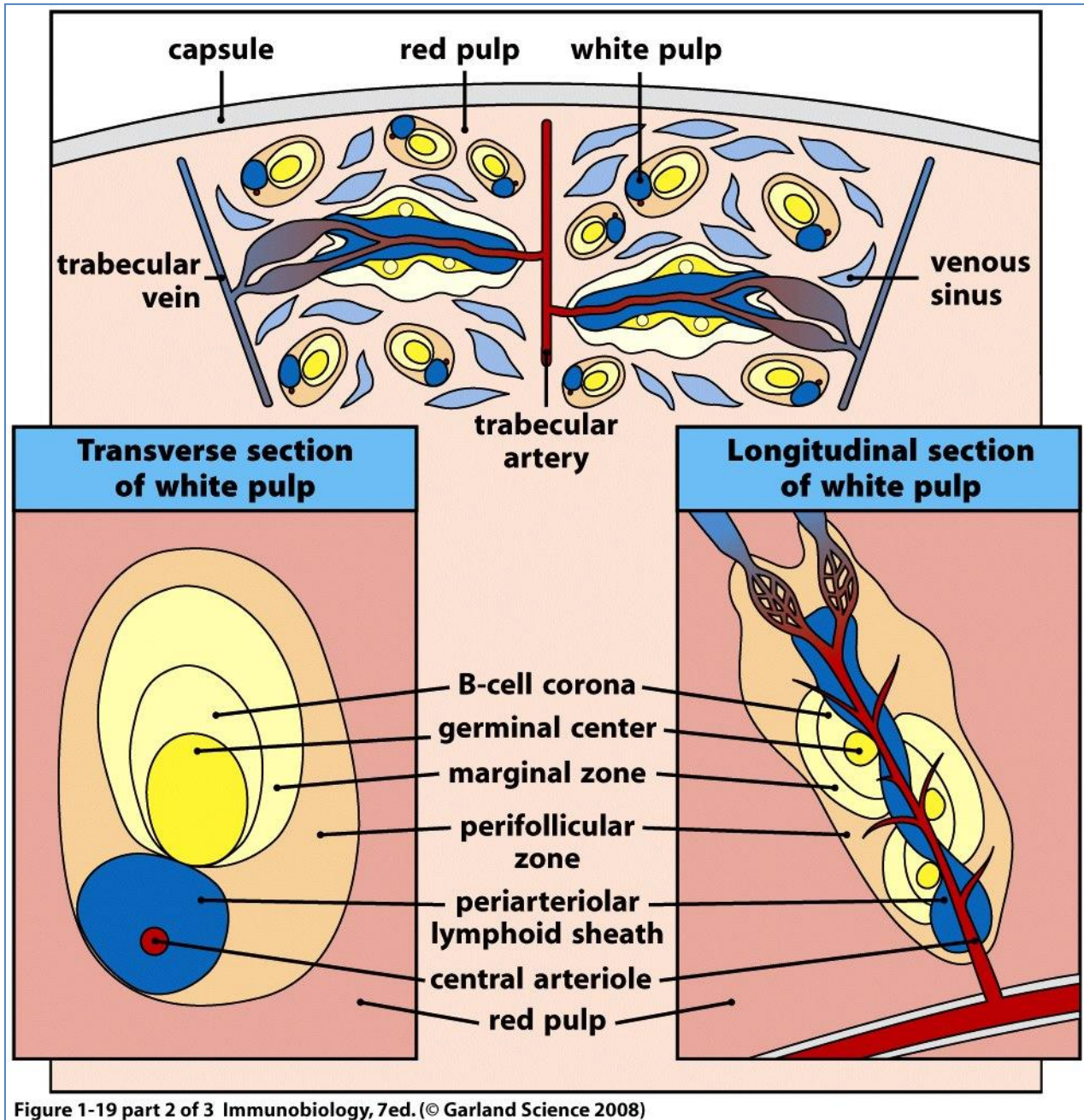
- Blood enters the spleen via the Splenic Artery carrying Lymphocytes & Antigen.
- The **Splenic Artery** divides into many Trabecular Arteries.
- **Trabecular Arteries** further divide into many **Central Arterioles** (surrounded by White Pulp - PALS) which branch off into terminal capillaries in the Perifollicular Zone.
- The **Central Arterioles** then drain into **Venous Sinuses**, which empty into **Trabecular Veins**.
- **Trabecular Veins** then merge into the Splenic Vein at the Hilum → Exits the Spleen.

Mechanism of Immune Function:

1. Antigen-Bearing **Dendritic Cells & Free-Antigen** in the Blood enter splenic tissue through capillaries in the Perifollicular Zone.
2. The blood-borne Microbes, Antigens & Ag:Ab complexes are filtered from the blood by Macrophages + Immature Dendritic Cells in the Marginal Zone.
3. The already activated Dendritic Cells & the newly activated Dendritic Cells then migrate to the Periarteriolar Lymphoid Sheath, where they present their antigens to their respective Naive T-Cells → Effector T-Cells.
4. Effector T-Cells then subsequently activate their respective Naive B-Cells (Both circulating B-Cells & B-Cells already in Marginal Zones/Coronas), causing them to proliferate and migrate into nearby Germinal Centres, where they continue to rapidly proliferate.
5. Effector B-Cells differentiate into plasma cells & begin secreting Ab's. During this time Effector B-Cells undergo a process of selection where their receptors are tested for their ability to bind antigen. (Those that fail, will die)
6. Ab's & Effector T-Cells leave the Spleen via Venous Drainage and/or Efferent Lymphatics, & end up in the systemic circulation to fight the blood-borne infection.
 - CD4-T-Cells Activate Macrophages to make them more cytotoxic.
 - Antibodies bind to Antigens & recruit complement to: a) Lyse bacteria directly, or b) Opsonize them to enhance their phagocytosis.
 - In the case of a Viral Infection, activated CD8-T-Cells would kill any infected cells present.

- **Asplenia – Clinical Significance:**

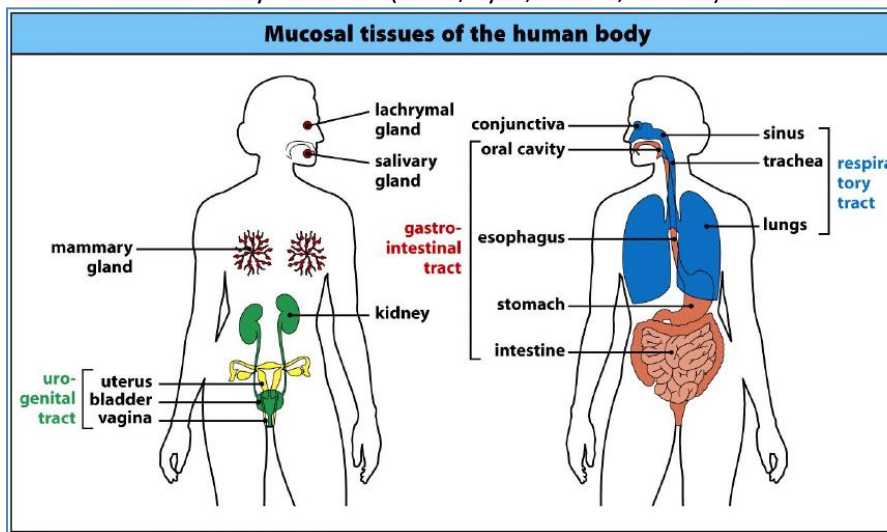
- Impaired clearance of Opsonised particles
- Susceptible to (Bacteraemia) blood-borne bacterial infections. (Primarily Encapsulated Bacteria)
- **Treatment:**
 - Prophylactic Antibiotics
 - Immunisation
 - Aggressive treatment of Infection.



Mucosal Associated Lymphoid Tissue (MALT):

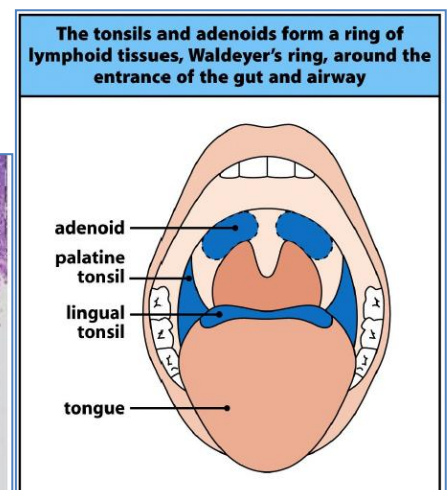
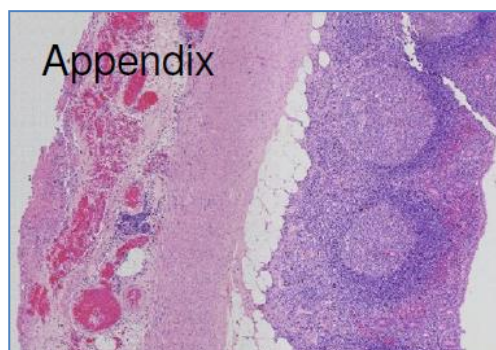
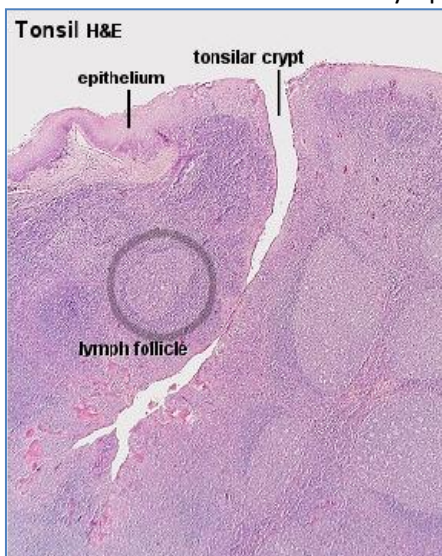
- Functions:

- Protects the Internal Mucosal Surfaces. (I.e. The Interfaces between External & Internal):
 - *Gastrointestinal Associated Lymphoid Tissue [GALT]
 - Bronchus Associated Lymphoid Tissue [BALT]
 - Genitourinary Tract.
- “Common” Mucosal Immunity:
 - Ag-Priming in One Mucosal Tissue confers Immunity @ Other Mucosal Surfaces.
 - Also confers Systemic Immunity.
- Why do Mucosal Surfaces require a specialised immune system?
 - Because most Mucosal Surfaces have a *One-Cell-Thick Epithelium* → Vulnerable.
 - Because mucosal functions involve *High Exposure to External Environment*:
 - I.e. Gas Transfer (lungs)
 - I.e. Food Absorption (GI)
 - I.e. Reproduction
 - I.e. Sensory Activities (Nose, Eyes, Throat, Mouth)



- Anatomy:

- Consist of Distinct ‘Accumulations’ of Lymphoid Tissue within the mucosa:
 - Eg. GALT – (Gut Associated Lymphoid Tissues):
 - Tonsils & Adenoids – surrounding entrance to GI & Respiratory Tract.
 - “Peyer’s Patches” – in the Small Intestines.
 - Solitary Lymphoid Nodules
 - Appendix
 - Smaller lymphoid patches exist in other mucosal surfaces.



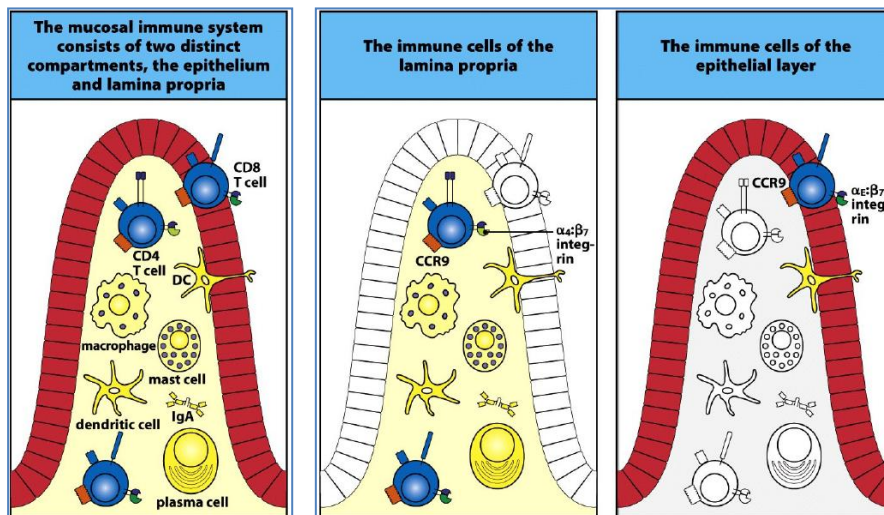
- **Protective Components of the GIT Mucosa:**

Non-Immune Components	Immune Components
Cell Barrier	Secretory Antibody
Mucous	Cell-Mediated Immunity
Gastric Acid	T-Cells (CD4, CD8 & $\gamma\delta$ T-Cells)
Microflora	Dendritic Cells
Proteolytic Enzymes	Macrophages & NK Cells
Motility	

- **Two Compartments of the Mucosal Immune System (& their Cellular Contents):**

1) The Epithelium	2) The Lamina Propria
'Intraepithelial' T-Cells (mostly $\gamma\delta$) Dendritic Cells	T-Cells (CD4 & CD8) B-Cells Plasma Cells Dendritic Cells Macrophages Mast Cells

- NB: 'CCR9' = a Chemokine receptor on T-Cells which aids in Migration back to MALT.



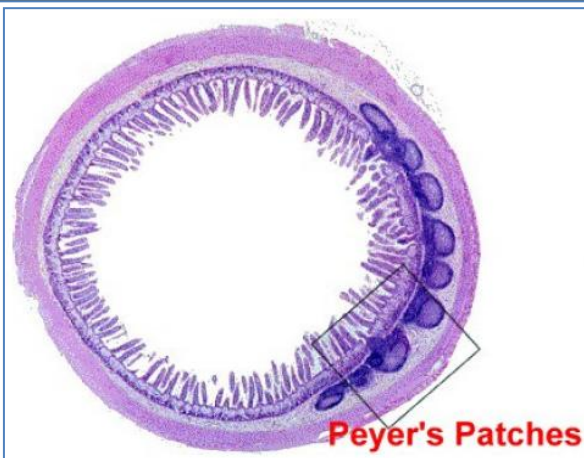
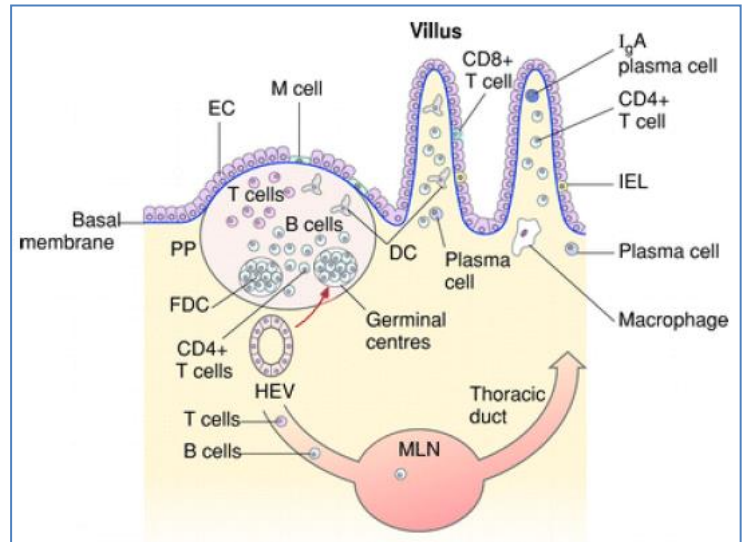
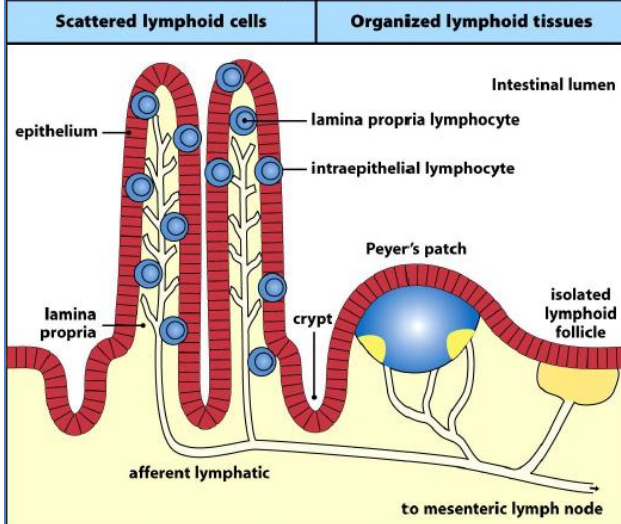
- **Two Organisations of the Mucosal Immune System:**

- **1) Organised Lymphoid Tissues (I.e. Peyer's Patches):**
 - - Sites of **Induction (Ag-Presentation & Activation of Naive Lymphocytes)**
 - - Peyer's Patches are Like *mini* Lymph Nodes.
 - Dome-like Structures extending into the Intestinal Lumen.
 - Epithelial Layer Contains '**M'-Cells (Microfold-Cells)** which transport Ag into Lamina Propria.
 - Contain Resident Dendritic Cells in the Lamina Propria.
 - Contain Constantly Re-Circulating Naive B- & T-Cells.
- **2) Scattered Lymphoid Cells:**
 - - Sites of **Effector Function (Cell-Mediated & Humoral Adaptive Immunity)**
 - Effector T-Cells. (Including Intraepithelial CD8 T-Cells)
 - $\gamma\delta$ -T-Cells
 - Effector B-Cells (Plasma Cells) – *IgA-Secreting*.
 - Resident Innate Immune Cells (Macrophages/Mast-Cells/etc)

- **Lymphocyte Circulation – From Peyer's Patches → Blood/Lymph → Scattered MALT:**

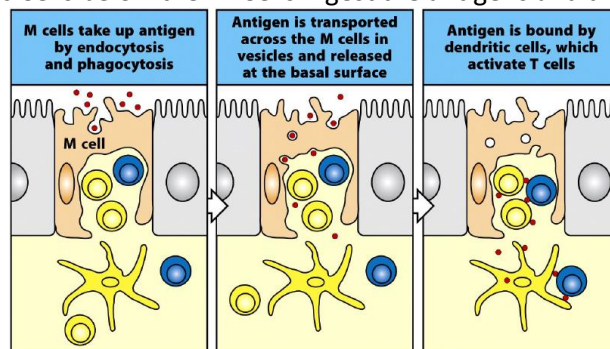
- Circulation of Lymphocytes between the Mucosal Immune System & blood/lymph is controlled by Tissue-Specific Adhesion Molecules & Chemokines.
- NB: 'CCR9' = a Chemokine receptor on T-Cells which aids in Migration back to MALT.

Intestinal lymphocytes are found in organized tissues where immune responses are induced, and scattered throughout the intestine, where they carry out effector functions

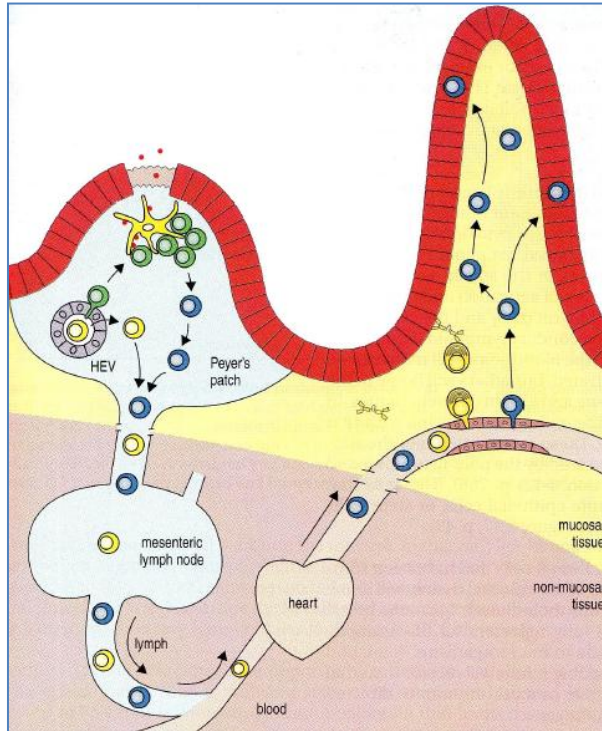


Peyer's Patches – Mechanism of Immune Function:

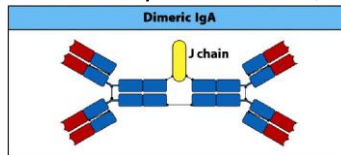
- M-Cells (microfold cells)** take up Antigens/Pathogens by Endocytosis or Phagocytosis, and then release Antigen Fragments at their *Basal Surface*, where Naive B-Cells & Dendritic Cells are waiting:
 - Specific Naive B-Cells bind & internalise their Ags; and then display them on MHC-II.
 - Dendritic Cells below the M-Cells ingest the antigens and display them on MHC-I & MHC-II.



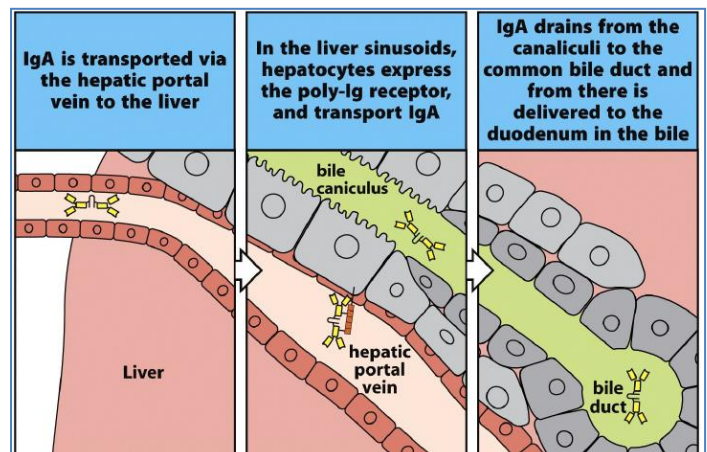
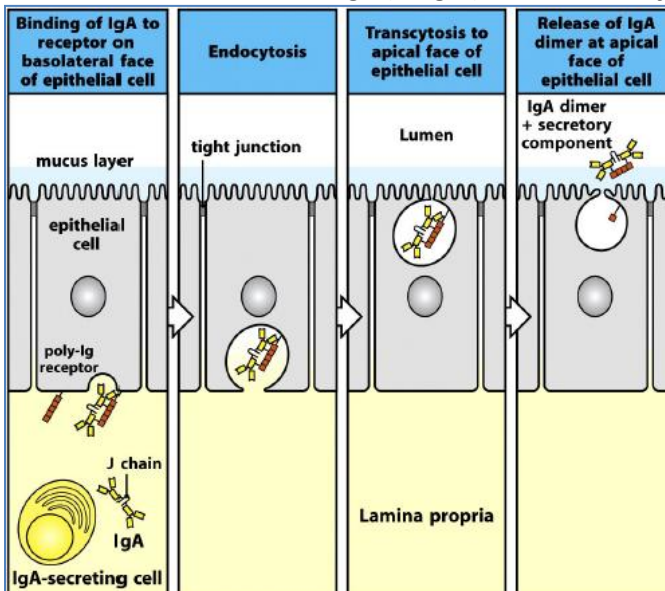
- CD4-T-Cells** specific to the Ags displayed on Dendritic Cells are Activated to Th-Cells by Dendritic Cell.
- CD8-T-Cells** specific to the Ags displayed on Dendritic Cells are Activated to Tc-Cells by Dendritic Cell.
- Effector Th-Cells** then find their Ag-Specific B-Cells and Activate them to start differentiating into IgA-Secreting Plasma Cells.
- Effector CD4, CD8 & B-Cells** leave the Peyer's Patches via the Lymphatics → Lymph Node.
- These activated Effector CD4, CD8 & B-Cells proliferate and finish differentiating in the Lymph Node.
- Thousands of CD4, CD8 & B-Cell Clones leave the Lymph Node → Blood.
- Once in the blood**, these effector clones migrate back to the Mucosal Tissue through HEVs.
 - NB: Lymphocytes activated in Peyer's Patches express a special Chemokine Receptor called CCR9, which is specific to a Chemokine expressed only on mucosal HEVs (Especially when inflamed).



9. **Effector CD8 T-Cells** which return to MALT kill any virally-infected Enterocytes or become intraepithelial cells.
10. Once **Effector B-Cells** (Now Plasma Cells) are back in the MALT, they begin secreting IgA.
 - i. NB: IgA is a Dimer joined by a '**J-Chain**'.
 - ii. NB: IgM may also be secreted by some B-Cells; and *also* has a '**J-Chain**'.

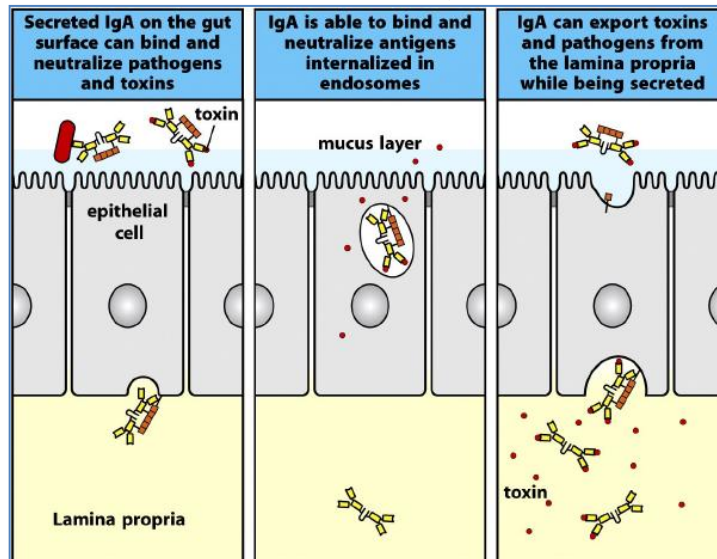


11. **Antibodies** secreted within the Lamina Propria can do different things:
 - i. Activate Complement by the Alternative Pathway
 - ii. Neutralise Antigens in the Lamina Propria
 - iii. Opsonise Antigens for Phagocytosis
 - iv. Bind to Phagocytic Cells → Initiates Oxidative Burst & Release Inflammatory Cytokines.
 - v. Can be Transported across the epithelium...see below:
12. '**J-Chain**' on IgA (or IgM) binds to the '**Poly-Ig Receptor**' on the basal membrane of the epithelial cell.
 - i. IgA (or IgM) is then **Transcytosed** across the epithelium and into the intestinal lumen.
 - ii. NB: Antibodies can also transported into the Bile Canaliculi & Mammary Glands (Breasts).
 - iii. NB: IgA (or IgM) in its **secreted form** = sIgA (or sIgM)



13. sIgA Antibodies (in the intestinal lumen) can ONLY Neutralise Antigens.

- i. Why? – Because all other antibody functions require either *Complement* or *Phagocytes*, which don't exist in the intestinal lumen. (As the lumen is an '*Immune Privileged*' site)



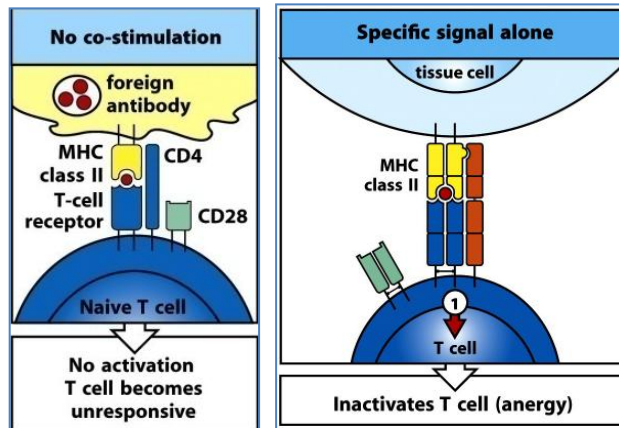
▪ **NB: IgA-Deficiency – Why are most people affected asymptomatic?**

- Due to IgM's ability to replace IgA as the predominant antibody in secretions.
- NB: IgM is the only other Antibody with a J-Chain, & hence the only other able to be transcytosed.

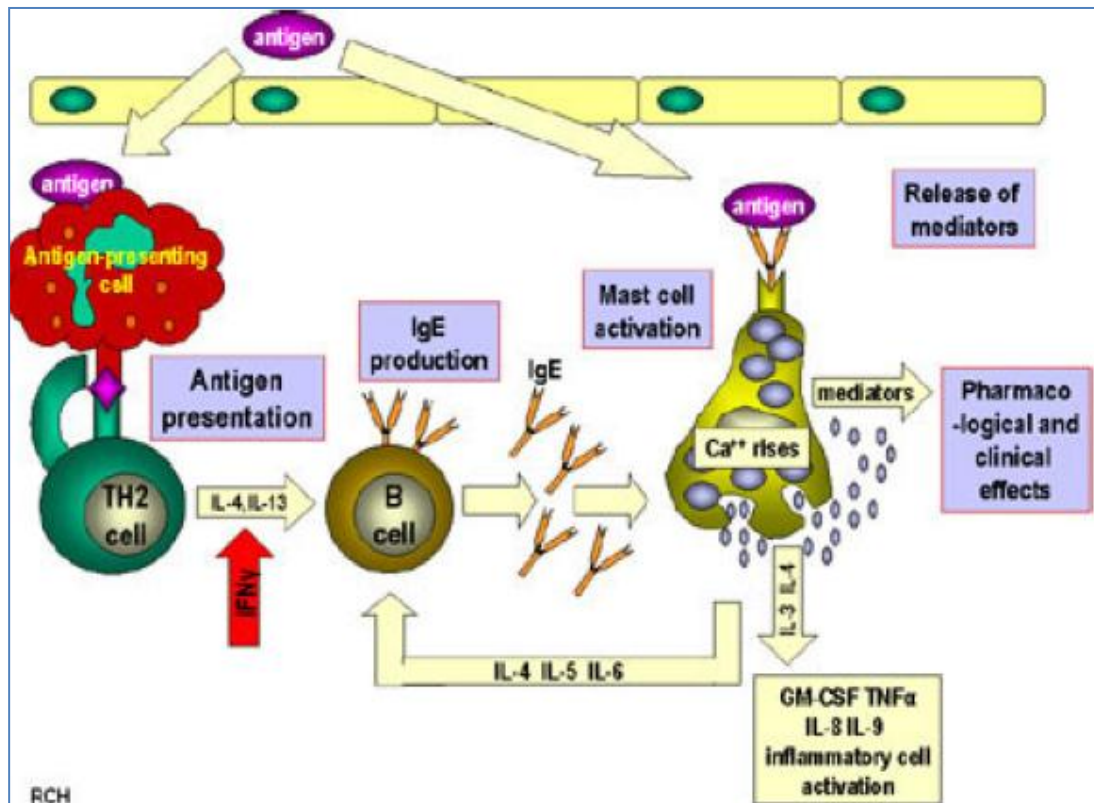
Oral Tolerance

Response to Food Antigens - ('Protective Immunity' or 'Oral Tolerance'):

- Normally, Food Antigens DO NOT stimulate an Immune Response; Instead they Induce *Tolerance*:
 - o **How?** – Remember, Antigen Presentation *Without Co-Stimulation* is NOT ENOUGH to Activate T-Cells; and actually Inactivates the T-Cells instead → Tolerance.
 - o **Full T-Cell Activation Requires Cytokines** from the Innate Immune system to become fully activated.
 - Therefore, non-infective Ags, which don't stimulate the Innate Immune System (or release of cytokines), WILL NOT activate T-Cells. → Tolerance
 - o **Also, Inflammatory Cytokines cause APCs to express Co-Stimulatory molecules**, so without them, full T-Cell Activation is impossible.



- **Abnormally, Food Antigens may stimulate an Immune Response → Activating Th-Cells:**
 - o **1st Exposure:** Activated Th-Cells specific to a Food Antigen will then Activate Ag-Specific B-Cells → Produce Antibodies against the Food Ag.
 - o **Subsequent Exposure:** Antibodies bind Food Antigen. Then Ab:Ag-Complexes bind to Mast Cells:
 - → Mast Cells Degranulate → Release Histamine
 - Histamine → Vasodilation, ↑Vascular Permeability & Upregulation of Cell Adhesion Molecules.
 - → Crams, Vomiting, Diarrhoea, Angio-Oedema.



Innate Vs Adaptive Immune Responses:

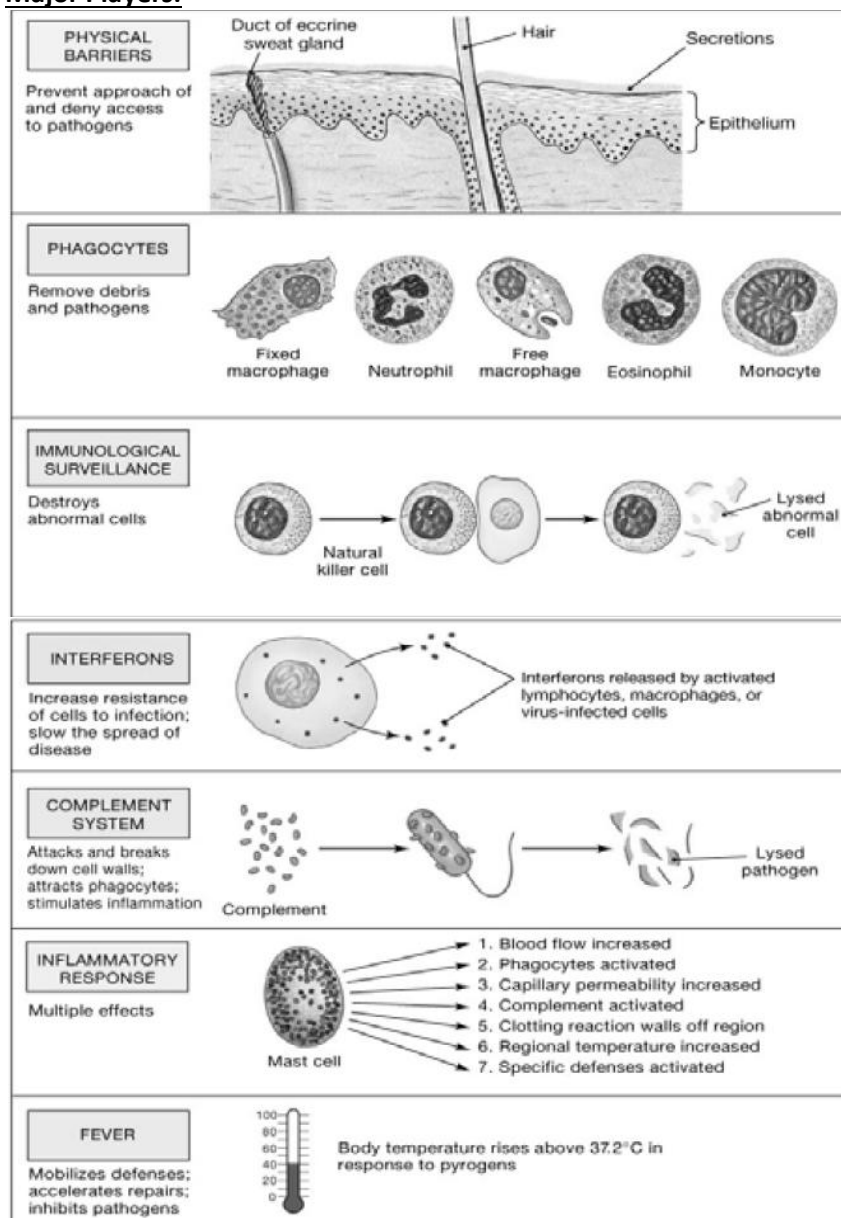
	Protective Elements			Characteristics		
	Barriers	Proteins	Cells	Specificity	Memory	Tolerance
Innate	Skin Epithelia Chemicals	Complement system Inflammation (Acute Phase Proteins)	Phagocytes and NK cells	PAMPs	No	Yes
Adaptive	Epithelial-Lymphocytes	Antibodies	Lymphocytes (T and B)	Specific Antigens on microbe surface	Yes	Yes

Innate (non-specific) Immune System → The body's first line of defence:

The Passive, Rapid and Non-Selective mechanisms of the immune system that defend the host from infection. Unlike the adaptive immune system, it doesn't confer long-lasting immunity (memory).

- "The body's Passive Barriers & Foot-Soldiers"
- Already in place at birth.
- Is always prepared
- Responds within minutes
- Non-Selective (Protects the body from all foreign substances).
- Are often sufficient to ward off invading pathogens single-handedly.
- Essentially, it reduces the workload of the adaptive system.

Major Players:



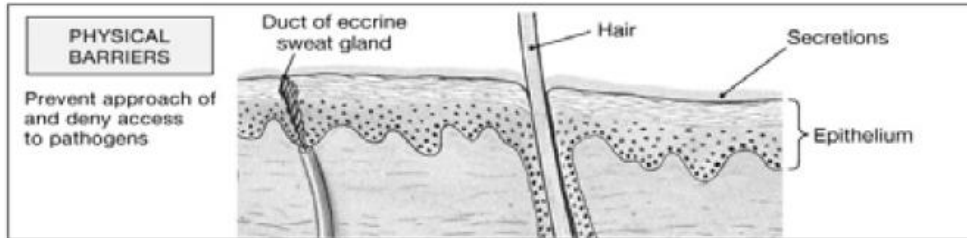
○ **Physical & Chemical Barriers → Prevent Entry of Pathogen:**

▪ **Skin**

- Stratified
- Heavily keratinised

▪ **Mucous membranes**

- Lysozyme: enzyme found in saliva & tears → destroy bacteria.
- Sticky Mucus: in digestive & respiratory tracts → traps bacteria.
- Cilia – nasal & respiratory → sweep bacteria into mouth → swallowed.
- Acid secretion: skin, vagina, stomach → kills microbes.



○ **Internal Defences → Prevent Spread of Pathogen If Surface Barriers are Breached:**

▪ **Cells Involved in Innate Immune Responses:**

- **Macrophages:** (“Big Eaters”) Large, migratory, Phagocytic cells derived from bone-marrow precursors & found in Tissues throughout the body. They are involved in all phases of the immune system;
 - Engulf and Kill invading Microorganisms – Innately
 - Engulf and Kill Microbes ‘marked’ by an Adaptive Immune Response.
 - Eg. Agglutinated Ag:Ab complexes
 - Scavenge dead cells & general debris.
 - Help induce Inflammation (Required for an effective immune response), secreting Pro-Inflammatory Cytokines (specifically those that induce the Acute Phase Response) & Chemokines.
 - Antigen-Presentation to T-Helper Cells

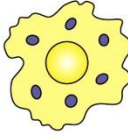
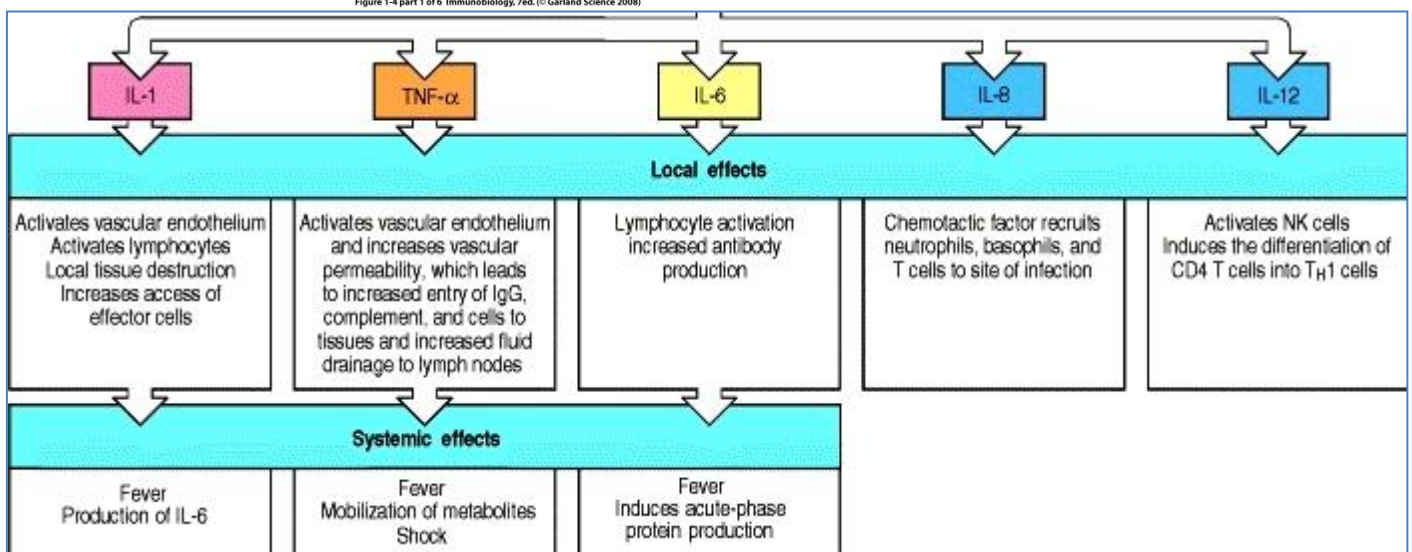
Cell	Activated function
Macrophage 	Phagocytosis and activation of bactericidal mechanisms Antigen presentation

Figure 1-4 part 1 of 6 Immunobiology, 7ed. (© Garland Science 2008)



- **Granulocytes:** “Granulated Cells” named according to the stain-ability of the cytoplasmic granules. They are ‘Polymorphonuclear’ – (Multi-shaped lobed nucleus)
 - **Neutrophils:** Neutral-Staining Granules. → Anti-Bacterial Role(Phagocytosis).
 - Most Numerous in blood samples 40-75%.
 - Most Important Granulocyte.
 - **Phagocytic** – Engulf invaders coated with Antibodies & Complement, damaged cells & debris.
 - Life-span = 5 days (NB: Neutrophils don’t return to the blood; they turn into Pus.)


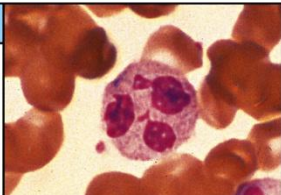
Cell	Activated function
Neutrophil 	 Phagocytosis and activation of bactericidal mechanisms

Figure 1-4 part 3 of 6 Immunobiology, 7ed. (© Garland Science 2008)

- **Eosinophils:** Red-Staining Granules with **Eosin** Dye. → Anti-Parasite & Anti-Fungal Roles.
 - Weakly Phagocytic
 - Life-Span = 12 Days in Tissues - OR - 30min in Blood
 - Kills extracellular organisms (eg. Parasites) by excreting toxic chemicals onto their prey.
 - Involved in Antigen Presentation & Destroy Tumour Cells.

Cell	Activated function
Eosinophil 	 Killing of antibody-coated parasites

Figure 1-4 part 4 of 6 Immunobiology, 7ed. (© Garland Science 2008)

- **Basophils:** Granules stain with **Basic** Dyes. → Hypersensitivity & Allergic Reactions.
 - Least Numerous
 - Non-Phagocytic
 - Granules contain Histamine, Serotonin & Prostaglandins → ↑Inflammation, ↑Permeability of Capillaries → ↑Phagocyte migration to site of infection.


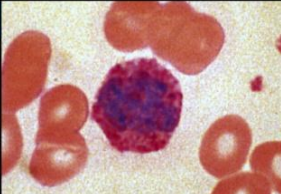
Cell	Activated function
Basophil 	 Unknown

Figure 1-4 part 5 of 6 Immunobiology, 7ed. (© Garland Science 2008)

- **Natural Killer cells:** Large, Granular, **Lymphoid-Derived** cells, which kill malignant cells, and cells infected by Intracellular pathogens (viruses/bacteria).
 - Can lyse & kill cancer cells & virus-infected cells
 - Target all cells that lack 'self' surface receptors (non-specific)
 - Latches onto invaders and induces apoptosis.

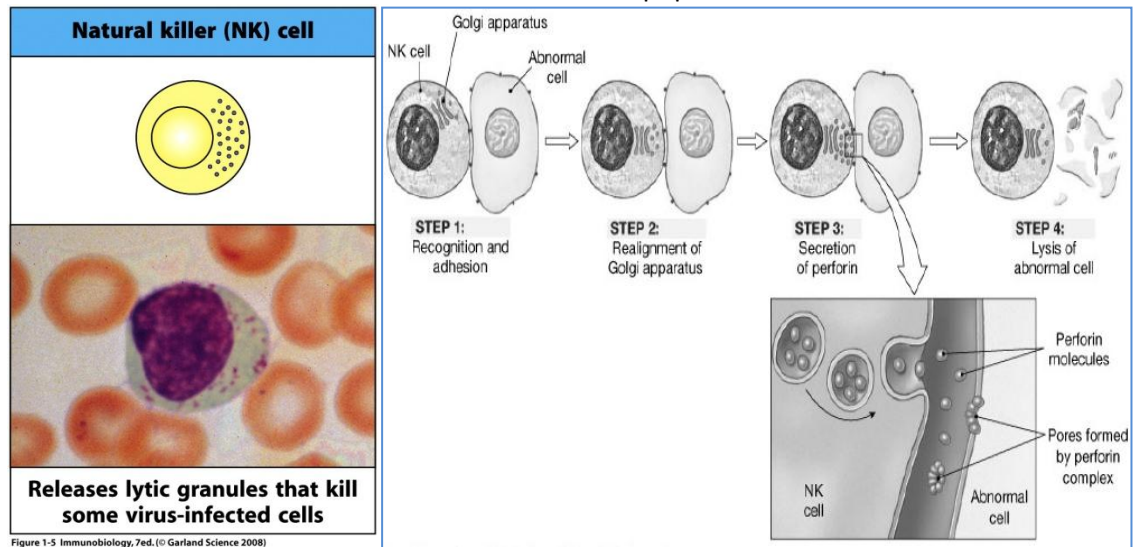
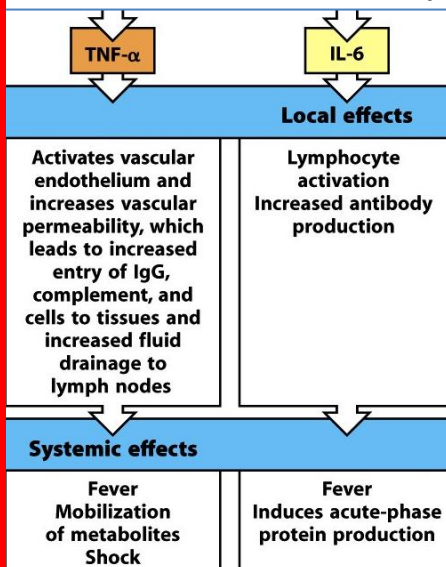


Figure 1-5 Immunobiology, 7ed. (© Garland Science 2008)

■ Inflammation

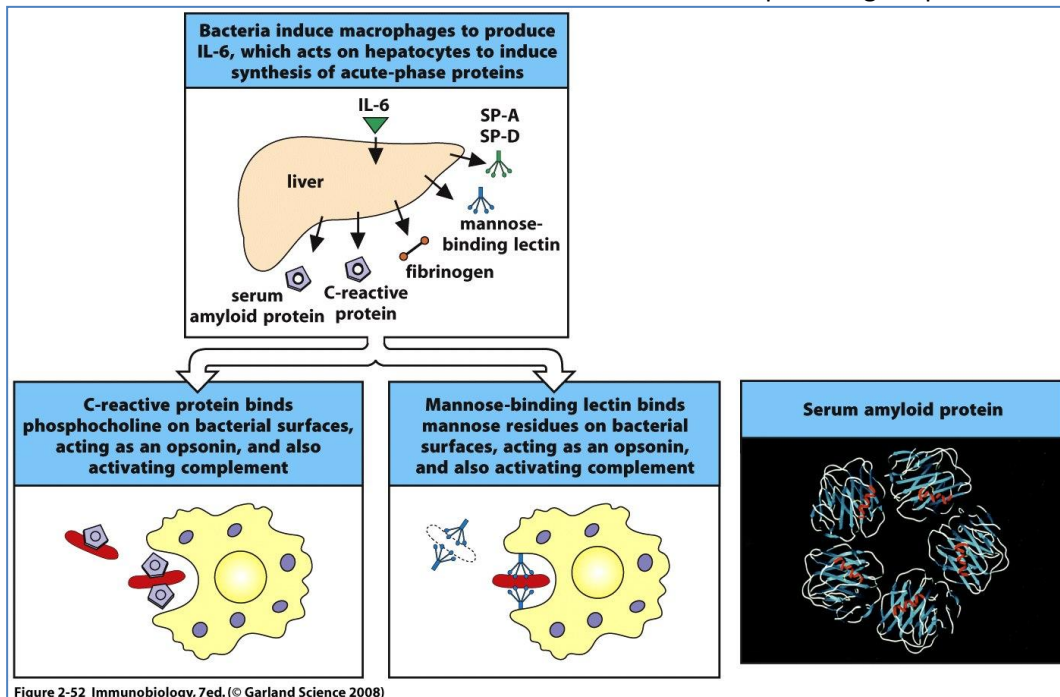
- In response to physical trauma/intense heat/bad chemicals/infection.
- Injured cells secrete Cytokines?
- Attracts Macrophages, Neutrophils & Lymphocytes to the Injured/Infected Area.
- Characterised by **heat, redness, pain & swelling**
- **Cytokines are Important Mediators:**



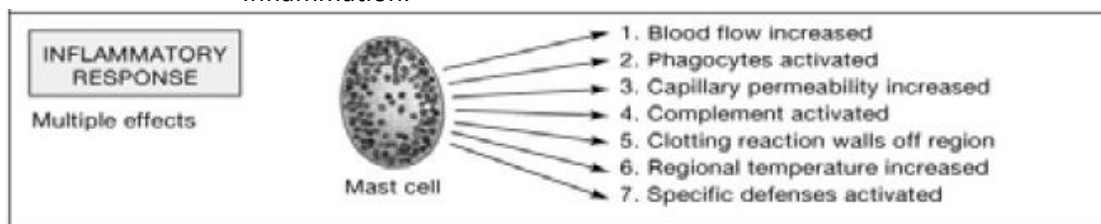
- **IL-6:**
 - Pyrogenic action on Hypothalamus \rightarrow Fever
 - Stimulates the Acute Phase Response (in liver).
 - Activates Lymphocytes during Antigen-Presentation.
- **TNF- α :**
 - Pyrogenic action on Hypothalamus \rightarrow Fever
 - Induces *Local Inflammatory Response* \rightarrow Helps Contain Infection.
 - \uparrow Blood Flow
 - \uparrow Vascular Permeability
 - \uparrow Endothelial Adhesiveness (For Leukocytes & Platelets)
 - NB: This can be maladaptive in Sepsis \rightarrow Septic Shock.
 - Induces the Acute Phase Response (in liver).
 - Stimulates Dendritic-Cell Migration to Lymph Nodes.

- **NB: Septic Shock** – Systemic Release of pro-inflammatory cytokines (**TNF, IL-1, IL-6, IL-8, IFN**) from Neutrophils/Macrophages/Endothelial cells, plus pro-inflammatory Complement \rightarrow Systemic Vasodilation (blood-pooling) (amongst other things) \rightarrow $\downarrow\downarrow$ BP \rightarrow **Septic Shock**.

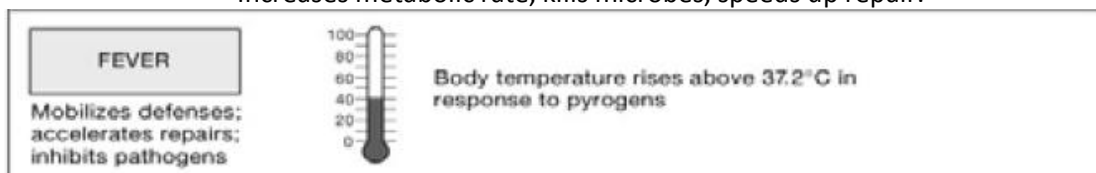
- **Acute Phase Proteins:** A class of proteins produced by the liver in response to Inflammatory Cytokines (IL-1, **IL-6** & TNF_α). **Relevant Examples include:**
 - **CRP – (C-Reactive Protein) →**
 - An Opsonising Agent for microbes → Phagocytosis (Similar action to Antibodies – except have broad specificity for PAMPs)
 - Also Activates the **Classical Pathway of the Complement Cascade.**
 - **MBL – (Mannose-binding Lectin) →**
 - Also an Opsonising Agent for microbes → Phagocytosis.
 - Also Activates the **Lectin Pathway in the Complement Cascade.**
 - **SP-A & SP-D:**
 - Found in Alveolar Fluid & Also have Opsonizing Properties.



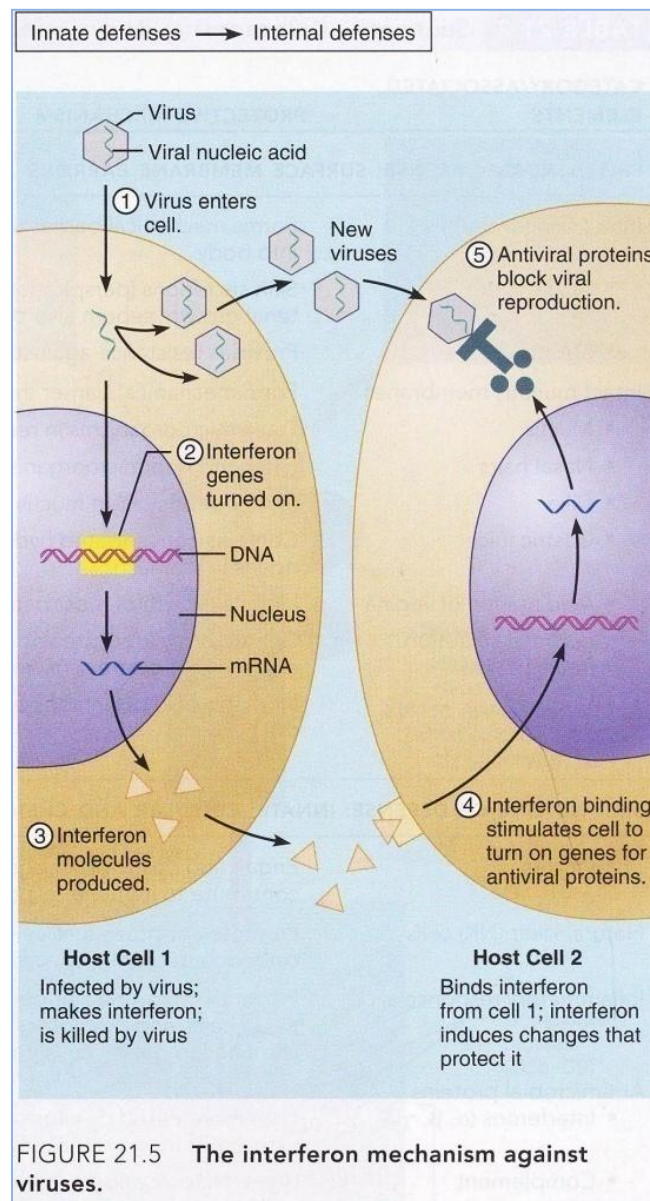
NB: Measurement of acute-phase proteins, especially CRP, is a useful marker of Inflammation.



- **Fever**
 - When exposed to foreigners, leukocytes & macrophages secrete pyrogens → increases the body's thermostat.
 - Increases metabolic rate, kills microbes, speeds up repair.



- **Antimicrobial Proteins** - Either attack microbes directly or reduce their reproductive ability.
 - **Interferon Proteins** – Virally Infected cells secrete Interferons (IFNs) to protect cells that haven't yet been infected. Interferons stimulate nearby cells to synthesize proteins which "interfere" with viral replication by blocking protein synthesis & degrading viral RNA. IFNs also attract Macrophages & NK Cells to destroy the infected cells.

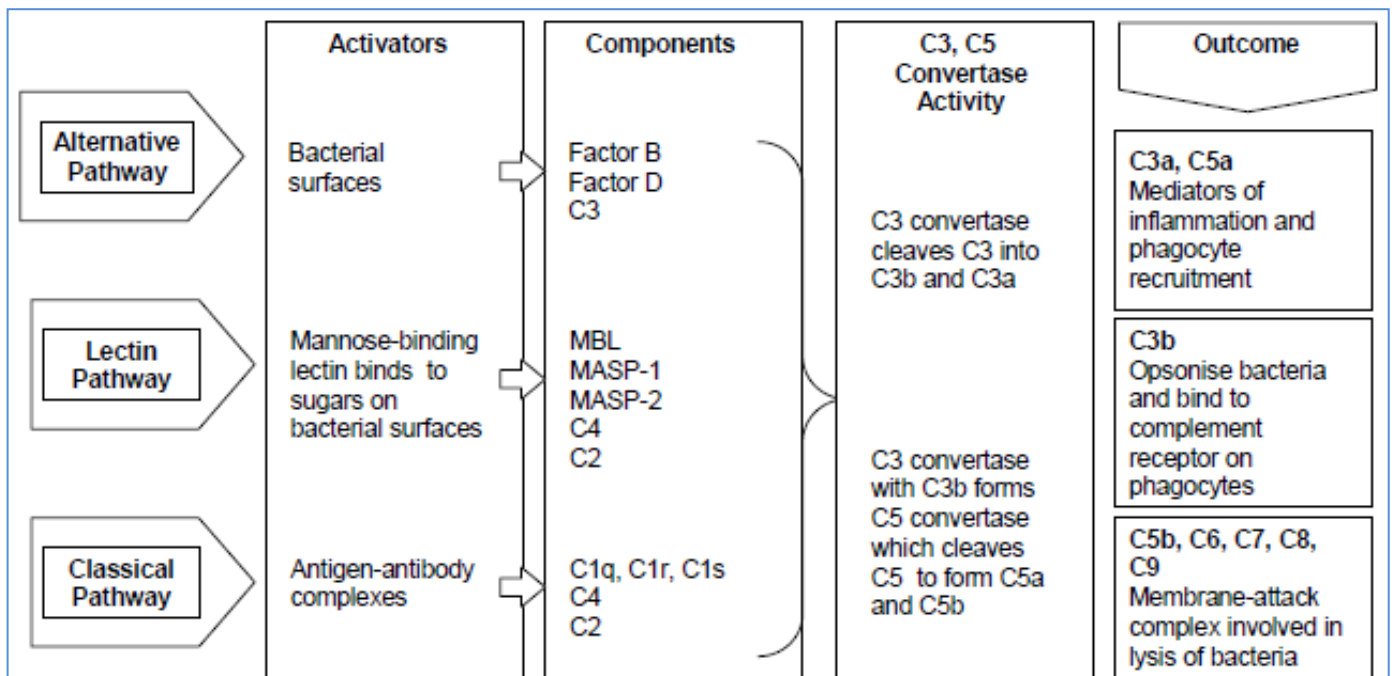


- **Complement Proteins** – A group of over 30 small Pro-Enzymes (Zymogens) produced by the liver, which are widely distributed through blood & tissues. When stimulated via one of 3 pathways (Classical, Alternative & MB-Lectin), self-amplifying proteolytic cascades are initiated leading to:
 - **1. Opsonisation of pathogens by C3b** → Targets foreign particles for Phagocytosis.
 - **2. Lysis of antibody-coated cells by the Membrane Attack Complex** → Creates a pore in the PM of bacteria.
 - **3. Chemotaxis by C5a** → Attracts Phagocytic cells to the area.

For the Detailed Process – See My Complement System Map!

NB: Although the complement system is part of the Innate Immune System, it has an important role in activating the Adaptive Immune System. It does this by:

1. Enhancing the uptake of complement-coated antigens by Antigen-Presenting Cells (as APCs have receptors for complement). &
2. Enhancing the response of B-Cells to complement-coated antigens (as B-Cells also have receptors for complement – act as co-stimulators)

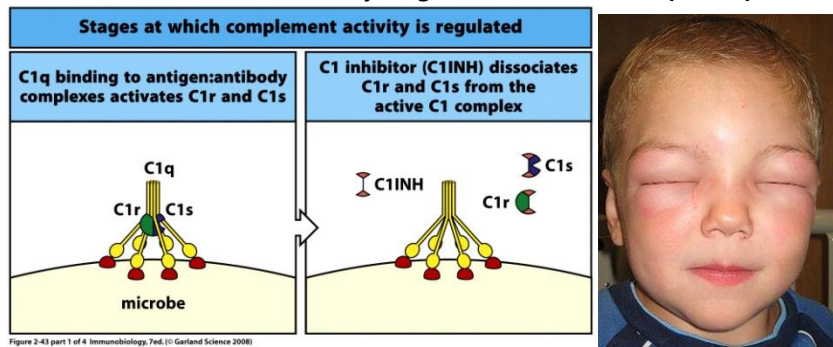


Results of Complement Deficiencies:

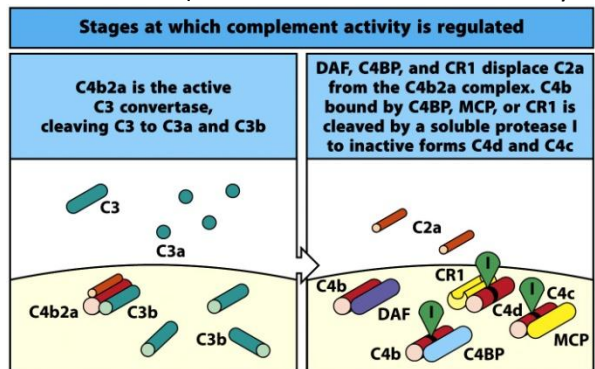
- **Deficiency in Classical Pathway:** → Poor processing of Immune Complexes & Clearance of Apoptotic Cells.
- **Deficiency in MBL Pathway:** → Typically associated with Bacterial Infections in early childhood (as the child's cellular immune system is being sensitised)
- **Deficiency in Alternate Pathway:** → Susceptibility to Extracellular Pathogens, particularly Bacteria.
- **Deficiency in the Terminal Pathway (Membrane Attack Complex):** → Results exclusively in susceptibility to *Nesseria Gonococcal*.

Regulatory Proteins – Protect the Host from Complement’s Destructive Effects:

- **C1INH** – (C1 Inhibitor) Limits the time during which Active C1-Complex is able to cleave C4 & C2. **Deficiency** → Chronic spontaneous complement activation → causes **Hereditary Angio-Neurotic Edema (HANE)**.



- **Factor I** – Protease that catabolises C3b.
- **Host-Cell Regulatory Proteins:** Proteins expressed on Host-Cell-Surfaces that either inactivate bound C3-Convertases, or inactivate bound C3b → iC3b. NB: Bacterial cell surfaces don’t express complement-regulatory proteins.
 - **CR1** – (Complement Receptor 1)
 - **DAF** – (Decay Accelerating Factor)
 - **MCP** – (Membrane Cofactor of Proteolysis)



- **CD59 (Protectin):** Prevents formation of the Membrane-Attack-Complex on ‘self’ cells.

Regulatory proteins of the classical and alternative pathways	
Name (symbol)	Role in the regulation of complement activation
C1 inhibitor (C1INH)	Binds to activated C1r, C1s, removing them from C1q, and to activated MASP-2, removing it from MBL
C4-binding protein (C4BP)	Binds C4b, displacing C2a; cofactor for C4b cleavage by I
Complement receptor 1 (CR1)	Binds C4b, displacing C2a, or C3b displacing Bb; cofactor for I
Factor H (H)	Binds C3b, displacing Bb; cofactor for I
Factor I (I)	Serine protease that cleaves C3b and C4b; aided by H, MCP, C4BP, or CR1
Decay-accelerating factor (DAF)	Membrane protein that displaces Bb from C3b and C2a from C4b
Membrane cofactor protein (MCP)	Membrane protein that promotes C3b and C4b inactivation by I
CD59 (protectin)	Prevents formation of membrane-attack complex on autologous or allogeneic cells. Widely expressed on membranes

Figure 2-42 Immunobiology, 7ed. (© Garland Science 2008)

Antigen-Presenting Cells: (The link between the Innate & the Adaptive Immune Systems) - Cells that engulf & process antigens, and then present fragments of them, like signal flags, on their own surfaces where they are recognised by T-Cells (Helper & Cytotoxic). NB: T-Cells are unable to independently recognise Antigens, & hence require Antigen Presentation). **Such APCs include:**

- **#1 Dendritic Cell:** The most efficient APC. Upon recognition of an infectious particle, it ingests & processes the antigen, and displays it on its cell surface, bound to either **MHC-I or MHC-II**. (NB: because Dendritic Cells present via MHC-I & -II, they can present antigens to **both Helper-T-Cells AND Cytotoxic-T-Cells**.) The Dendritic Cell then migrates to the nearest Lymph Node and activates 'Naive' T-Cells, which then leave the lymph nodes & travel to the site of infection.
- **Macrophages:** Part of the Innate Response. They possess various TLRs (Toll-like Receptors) that recognise patterns (PAMPs) on foreign organisms, which when activated, causes processing & presentation of the antigen via **MHC-II**, as well as **Cytokine Secretion**. **pMHC-II** then allows **T-helper-Cells** to bind to & further activate the Macrophage → More Phagocytic.
- **B-Lymphocytes:** The least efficient APC. Each recognises a specific antigen via its immunoglobulin-based surface receptors. Once ingested, the antigen is presented via **MHC-II** to **T-Helper-Cells**. The T-Helper Cell then *Activates the B-Cell* → Differentiates into a Plasma Cell → Secretes Antibodies.

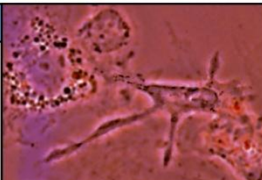
Cell		Activated function
Dendritic cell		Antigen uptake in peripheral sites Antigen presentation

Figure 1-4 part 2 of 6 Immunobiology, 7ed. (© Garland Science 2008)

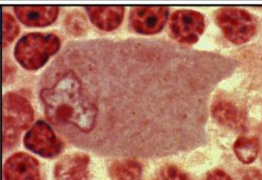
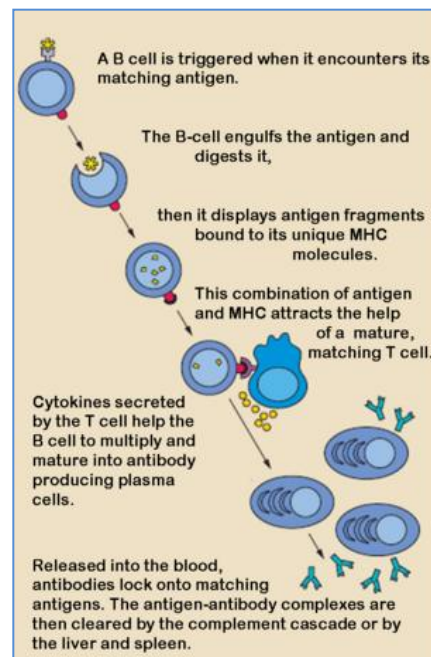
Cell		Activated function
Macrophage		Phagocytosis and activation of bactericidal mechanisms Antigen presentation

Figure 1-4 part 1 of 6 Immunobiology, 7ed. (© Garland Science 2008)



Adaptive (specific) Immune System → The Body's 2nd Line of Defence: The highly-specialised mechanisms of the immune system that, once activated by the Innate Immune System, has the ability to recognise & remember specific pathogens and mount stronger attacks each time the pathogen is encountered.

- "The body's elite special forces" – equipped with high-tech weapons.
- Stimulated by Exposure to the Infectious agent.
- **May be either Humoral OR Cell-Mediated depending on the Microbe.**

Humoral Immunity	Cell-mediated Immunity
The immunity can be transferred from one individual to another via serum	The immunity can be transferred from one individual to another via effector cells
The immunity is due to the formation of antibodies	The immunity is due to the formation of activated cells
An important function of antibodies is to neutralise toxins and infectious organisms	An important function of the activated cells is to destroy infected or foreign cells

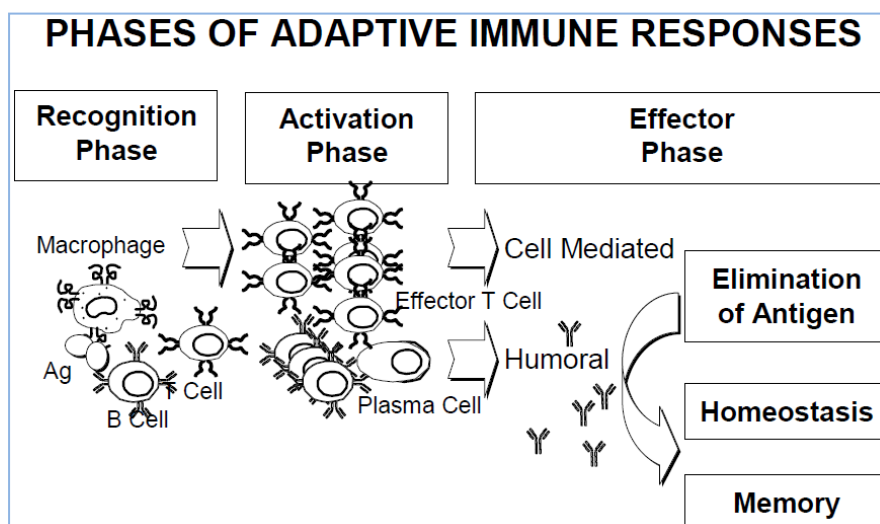
- **Involves Mainly Lymphocytes (B & T) And Dendritic Cells.**
- Adaptive responses are called into action as 'reinforcements'
- Takes much more time to mobilise than the innate response.

5 Characteristics:

- **>It is Specific:** recognises *particular* pathogens/antigens
- **>It is Systemic:** immunity isn't restricted to initial infection site
- **>It has Memory:** mounts stronger attacks on previously encountered pathogens.
- **>Self Limitation:** Immune response wanes off following elimination of antigens.
- **>Self-Tolerance:** Immune system non-reactive to self-antigens.

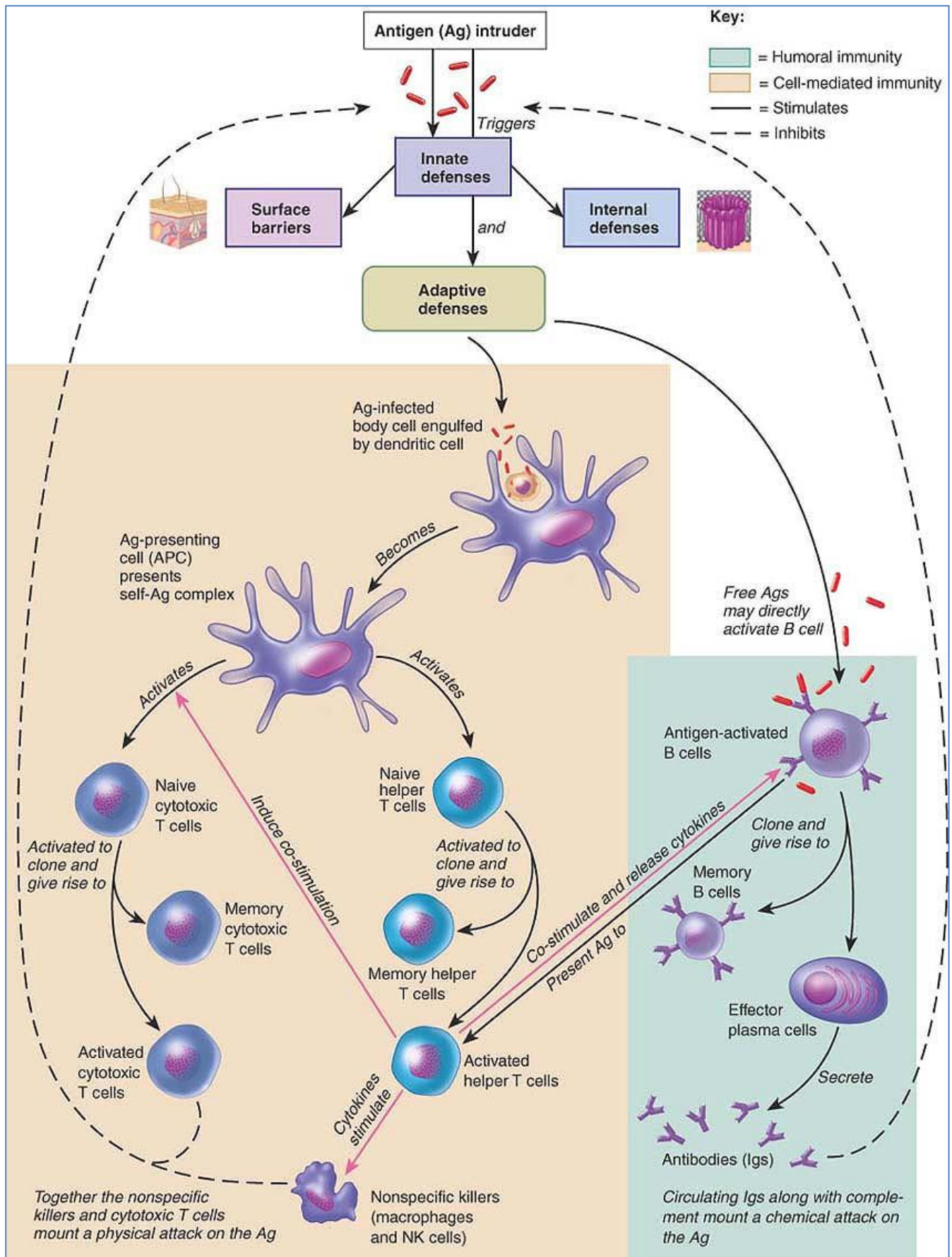
3 Phases:

- **Recognition Phase:** TLRs & PRRs on **Macrophages & Dendritic Cells** recognise **PAMPs** on the **Antigens**, & engulf them via **Phagocytosis**. The Antigen is processed, and bits of it are displayed on their cell surfaces to be 'presented' to T-Lymphocytes. Activated Macrophages & damaged epithelia secrete pro-inflammatory cytokines to attract more immune cells.
- **Activation Phase:** Activated Dendritic Cells migrate to Lymph Nodes, where they activate Naive T-Cells, → Which activate Naive B-Cells → secrete Antibodies.
- **Effector Phase:** Active T-Cells, as well as the secreted Antibodies, leave the Lymph Node and head back to fight the infection via the Lymph → Blood.



Major Players:

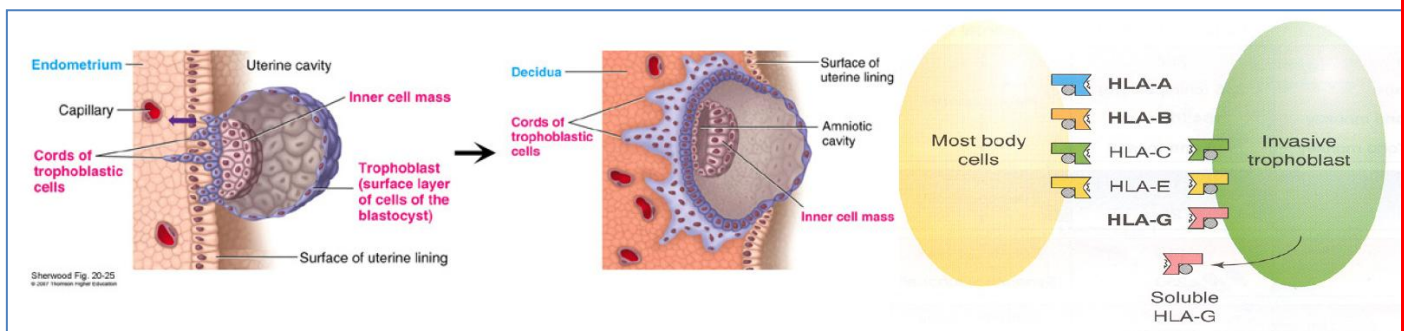
- **Lymphocytes:** Immune cells that originate in the bone marrow from Lymphoid Progenitor Cells, and are “educated” (i.e. Made immunocompetent) either in the Thymus (T-Cells) or the Bone Marrow (B-Cells). NB: Lymphoid organs where lymphocytes become immunocompetent (Thymus & Bone Marrow) are called “Primary Lymphoid Organs”; all the rest are Secondary.



IMMUNOLOGY Pathology: REPRODUCTIVE IMMUNOLOGY

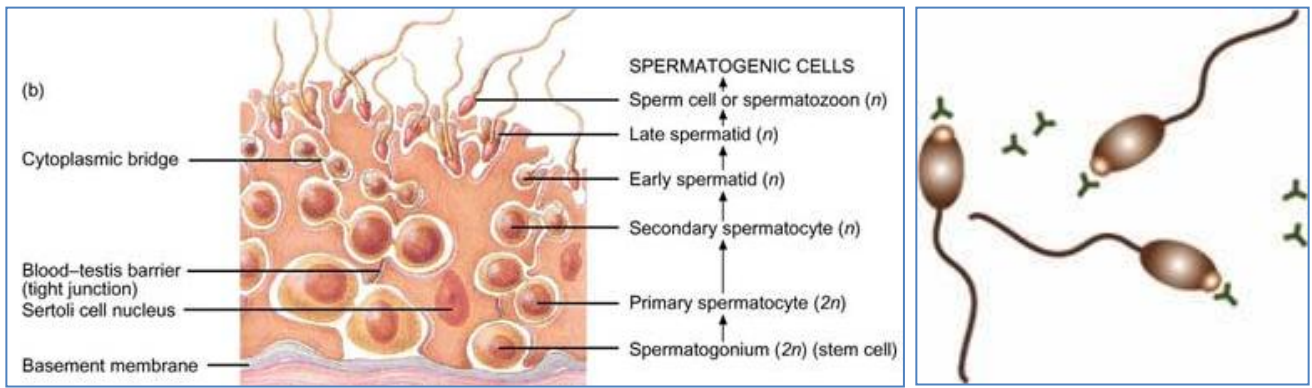
Placental Immunology: (How the Foetus Avoids Immune Rejection):

- Foetuses are 50% Foreign to the Mother and would usually lead to Immune Rejection via T-Cells.
- However, the Foetus can Survive; But the Mechanisms behind this are still largely unknown:
 - o NB: Self-immunosuppression of the mother is pointless, as this would leave the mother & foetus vulnerable to infection.
- Medawar's 3 Strategies for Foetal Survival:
 - o **1. Reduced/Modified MHC Antigen Expression on Trophoblasts:**
 - Foetal Trophoblasts DO NOT express Classical MHC-I molecules (I.e. Neither HLA-A or HLA-B).
 - They DO, however, express **HLA-G** (A NON-Polymorphic, NON-Classical MHC-I).
 - o *HLA-G* is thought to prevent NK-Cell Attack
 - Also express **HLA-C** & **HLA-E** which aren't recognised as foreign.
 - o *HLA-C* & *HLA-E* also bind to NK-Cells & prevents NK-Cell Attack.
 - → Lack of Antigen-Stimulation of Maternal Lymphocytes.
 - o **2. Modulation of Maternal Immune System:**
 - Immune cell functions change during pregnancy.
 - Trophoblast Secretions → *Cytokines* that Suppress *Local* T-Cells (Local)
 - High Progesterone & HCG → Immunosuppressive (General)
 - o **3. Placenta is a Physical Barrier which Can't be crossed by Lymphocytes:**
 - Although placenta is a Foetus-Derived tissue, its outer layer (Trophoblasts) is the only interface between Foetal & Maternal Tissues.
 - There is NO Vascular Continuity between Mother & Foetus.



Testicular Immunology: (How the Sperm Avoids Immune Attack):

- Sperm are highly Antigenic (since they are genetically unique).
- (In Males) – The '*Blood-Testes Barrier*' Protects the Sperm from the Immune System:
 - o Epithelial Barrier in Epididymis (joined by Tight Junctions) separate sperm from immune system.
 - o **Abnormalities of the Blood-Testes Barrier can expose Sperm to the Immune System:**
 - (Eg. Malformation, Trauma, Infection, Obstruction)
 - → Production of Anti-Sperm Antibodies → Possibly Infertility
- (In Females) – Sperm in Female Repro-Tract → Intense Inflammatory Response:
 - o Functions to remove excess sperm & microbes (≈24hrs post coitus)
 - o However, can → Production of Anti-Sperm Antibodies → Possibly Infertility.

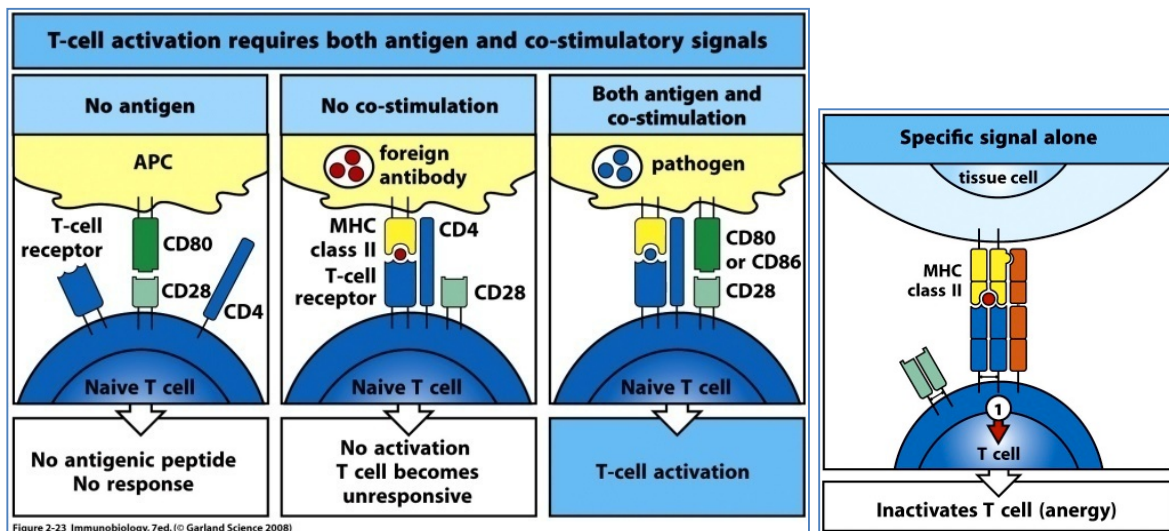


Transplant Immunology

REVISION OF TOLERANCE & MHC

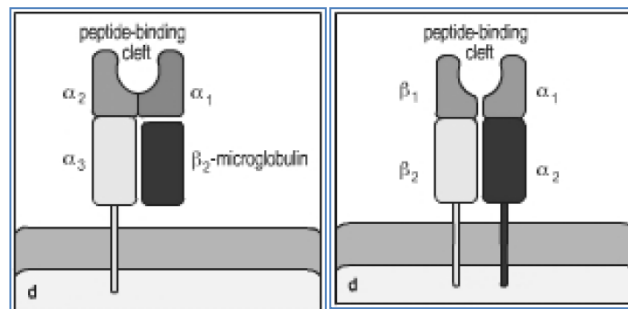
"Tolerance":

- **What is it?**
 - "The state of *Immunological Unresponsiveness* of the *Lymphoid Tissue* to a *Specific Antigen*"
 - **NB: Tolerated Antigens = "Tolerogens"**
- **Why is it important?**
 - Important in preventing *Autoimmunity*.
- **How is it achieved?**
 - **1. SELF-TOLERANCE ("CENTRAL TOLERANCE"):**
 - **Negative Selection of B-Cells & T-Cells in Primary Lymphoid Organs:**
 - Lymphocytes Reactive to Self-Ags are Clonally Deleted during development.
 - **NB:** However, it is impossible to expose all T-Cells to *every Self-Ag* since many of them aren't expressed in the Thymus. (See below for fail-safes)
 - *T-Cells are considered to be Mainly Responsible for Self Tolerance.*
 - **Fail-safes:**
 - B-Cells escaping negative selection require T_H-Cell Help to produce antibody.
 - T-Cells escaping negative selection are regulated by *other cells* in periphery.
 - **2. ACQUIRED IMMUNOLOGICAL TOLERANCE ("PERIPHERAL TOLERANCE"):**
 - **A) - TCR:Ag Recognition *Alone*, or Co-Stimulation *Alone* Is NOT ENOUGH to Activate T-Cells; and Can Inactivate the Reactive T-Cells → Tolerance.**
 - **NB:** This is a good safeguard in preventing activation of Auto-Reactive T-Cells.
 - **B) – Exposure to Exogenous Non-Inflammatory Antigens (eg. Dust/Pollen/Food) can → Tolerance:**
 - Full T-Cell Activation requires Cytokines from the Innate Immune system to become fully activated.
 - Therefore, non-infective Ags, which don't stimulate the Innate Immune System (or release of cytokines), WILL NOT activate T-Cells. → Tolerance

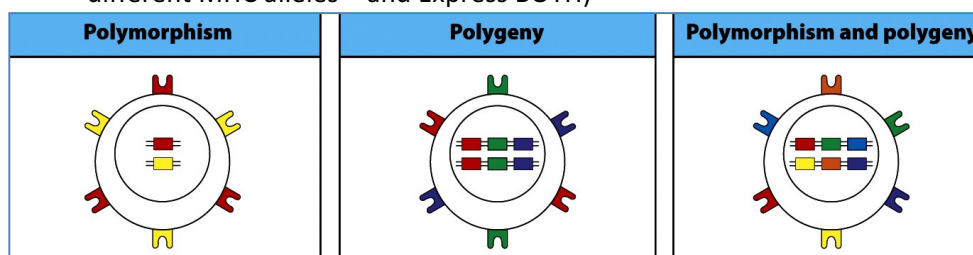


Major Histocompatibility Complex – MHCs (Self-Antigens):

- **NB: T-Cells can only recognise Ag when it is bound to Compatible MHC Molecules. (Not free Ag).**
 - Therefore, MHC's Main Function = To *Enable T-Cells* to recognise Antigen.
 - ***Epiphany : Classical MHC's are *ONLY EVER RECOGNISED* by T-Cells. No Other Cells do!**
- **What is MHC?**
 - MHC is also known as HLA ("Human Leukocyte Antigens")
 - Both MHC Classes are encoded by MHC Genes Located on the Short Arm of Chromosome 6.
 - Are Cell Surface GlycoProteins – ie. "Self Antigens":
 - High diversity of MHC throughout the population
 - (ie. Different people have different 'Self-Antigens')
 - – The Basis of Transplant Rejection.
 - NB: Identical twins have the same MHC's.
 - **Molecular Structure:**
 - **Structure of MHC-I:**
 - 2 Polypeptide chains
 - NB: One of the chains contains a β_2 Microglobulin which *Isn't* coded by MHC genes.
 - Only has 1x Intracellular Domain
 - **Structure of MHC-II:**
 - 2 Polypeptide Chains
 - Both domains of MHC-II are encoded by MHC Genes.
 - Has 2x Intracellular Domains

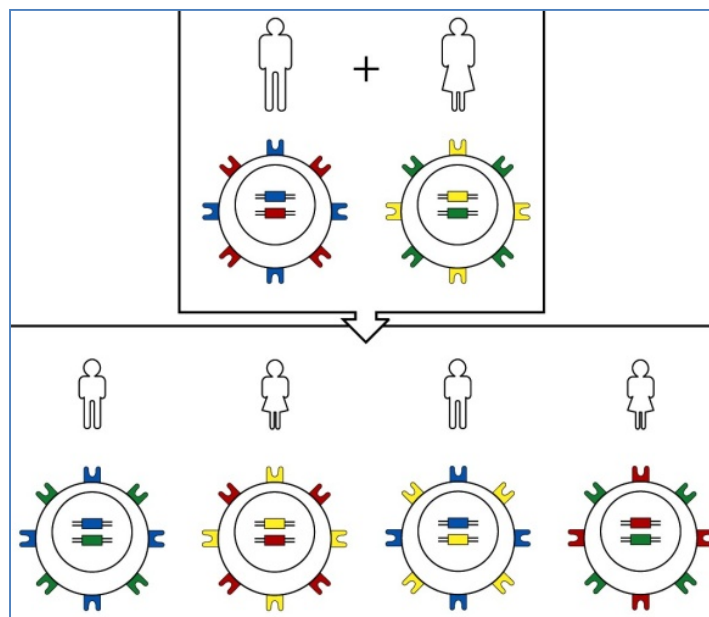


- **MHC Diversity – Due to *Polygeny & Polymorphism*:**
 - **Polygeny:**
 - There are Several Different Class I & II Genes throughout the population that seem to have the same functions.
 - NB: Genes are located on the *Short Arm* of Chromosome 6.
 - There are 3x Class-I Genes:
 - HLA-A
 - HLA-B
 - HLA-C
 - There are 3x Class-II Genes:
 - HLA-DR
 - HLA-DP
 - HLA-DQ
 - **Polymorphism:**
 - There are hundreds of Alleles of the above genes dispersed throughout the population.
 - NB: Expression of MHC Genes is **Codominant** (ie. People are usually Heterozygous for different MHC alleles – and Express BOTH)



- **MHCs Are Remarkably Similar Amongst 1st-Degree Relatives. Why?**

- **MHC Haplotypes** – **Linked sets of MHC Genes**, which are located at *Multiple Loci* on a single Chromosome, but are *close enough together* that they are *Inherited Together* as a Package.
- I.e. Haplotypes are too close together to be subject to Meiotic 'Cross-Over' (or 'Synapsis').

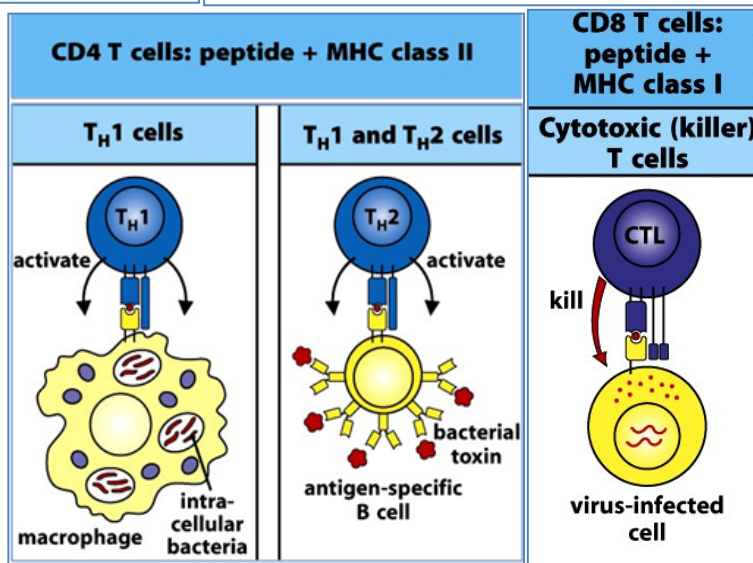
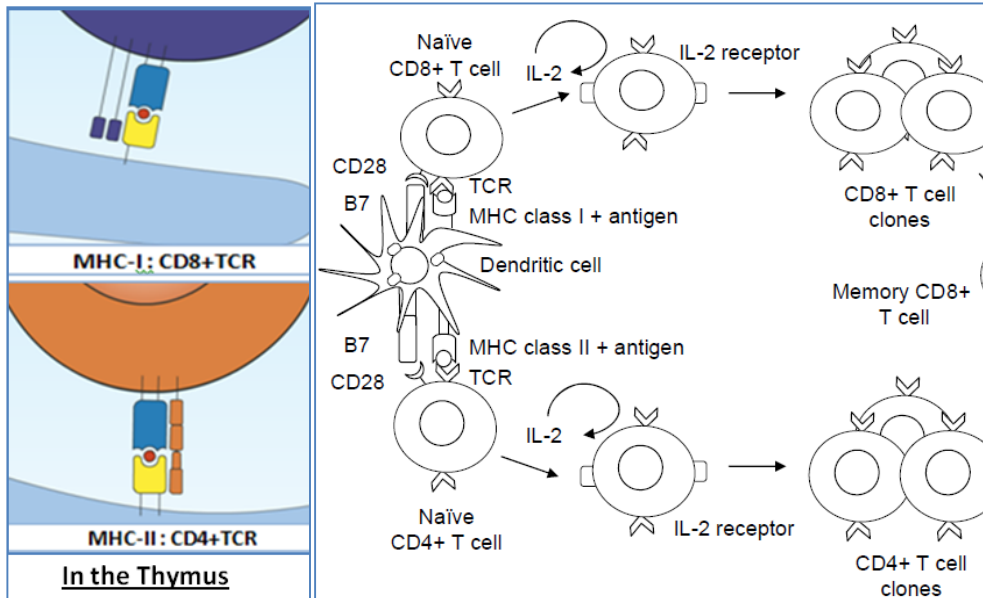


- **There are 3 Classes of MHCs & Their Specific Functions:**

- ***Class-I-MHCs:**
 - **Found on ALL Nucleated Cells & APCs. (These are the 'Self-Antigens')**
 - NB: Not Expressed on Red Blood Cells
 - - allow **Positive & Negative Selection of CD8-T-Cells [in the Thymus].**
 - - allow APCs to Present **Viral/Cancer Peptides to Cytotoxic T-Cells.**
 - - allow **Virally-Infected/Cancerous cells to be Targeted & Killed by Cytotoxic T-Cells**
- ***Class-II-MHCs:**
 - **Found ONLY on APCs & Semi-Active Macrophages & Semi-Active B-Cells.**
 - NB: Not Expressed on Red Blood Cells
 - - allow **Positive & Negative Selection of CD4-T-Cells [in the Thymus].**
 - - allow APCs to Present Antigen to Naive T_H-Cells → **Activates T_H-Cells to → Effector Cells.**
 - - allow **Partially-Activated Macrophages to Request T_H-Cell Help → More Phagocytic.**
 - - allow **Partially-Activated B-Cells to Request T_H-Cell Help → Fully Active B-Cells → Ab's.**
- **Class-III-MHCs:** Important in Complement & Cytokine production.

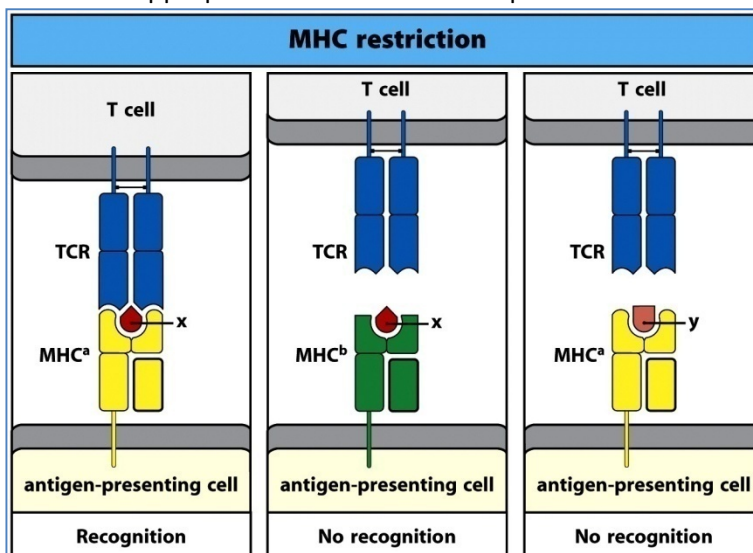
- **Summary of MHC Functions:**

- **Facilitate Antigen Presentation by APCs to T-Cells. (CD4 & CD8 – Depending on MHC Class):**
 - **[In the Thymus] APCs → Facilitate Positive & Negative Selection of CD4 & CD8 T-Cells.**
 - **[Outside Thymus]APCs→Alert Corresponding CD4 & CD8 T-Cells to the Presence of Antigen**
 - **NB. Remember:** T-Cell Specificity is *Genetically Determined* & therefore, Presentation of Ag to T-Cells only really *Alerts* the Relevant T-Cells to the *Presence* of Ag, and stimulates them to become Effector T-Cells. (I.e. APCs don't "*Sensitise*" T-Cells to Antigen, they just *Alert* them)
- **Allow Partially-Activated Macrophages to Request T_H-Cell Help:**
 - T_H-Cells help Macrophages to Become Fully Active → More Phagocytic.
- **Allow Partially-Activated B-Cells to Request T_H-Cell Help:**
 - T_H-Cells help B-Cells → B-Cells Become Fully Activated → Secrete Antibodies.
- **Allow Virally-Infected/Cancerous somatic cells to be Targeted & Killed by T_C-Cells:**
 - T_C-Cells recognise pMHC-I presented on virally-infected/cancerous cells → Kill Cells.



- **What is “MHC Restriction”?:**

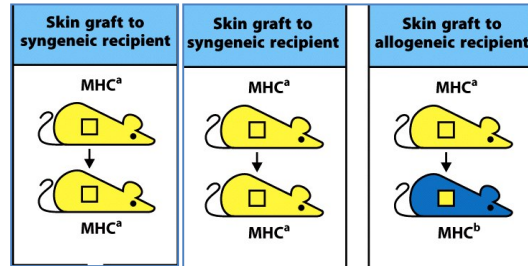
- T-Cell Antigen Recognition is “MHC-Restricted”, Meaning:
 - A T-Cell Receptor (TCR) will only bind to a Peptide-MHC Complex on 2 Conditions:
 - 1) The MHC Molecule is Compatible
 - 2) The Peptide displayed is Specific to that TCR.
- **NB: Some Pathogens Disable MHC Restriction by Production of *Superantigens*.**
 - Leads to→ Inappropriate activation of Non-Specific T-Cells→ Maladaptive Immune Response



TRANSPLANT BASICS:

- Terminology of Transplant:

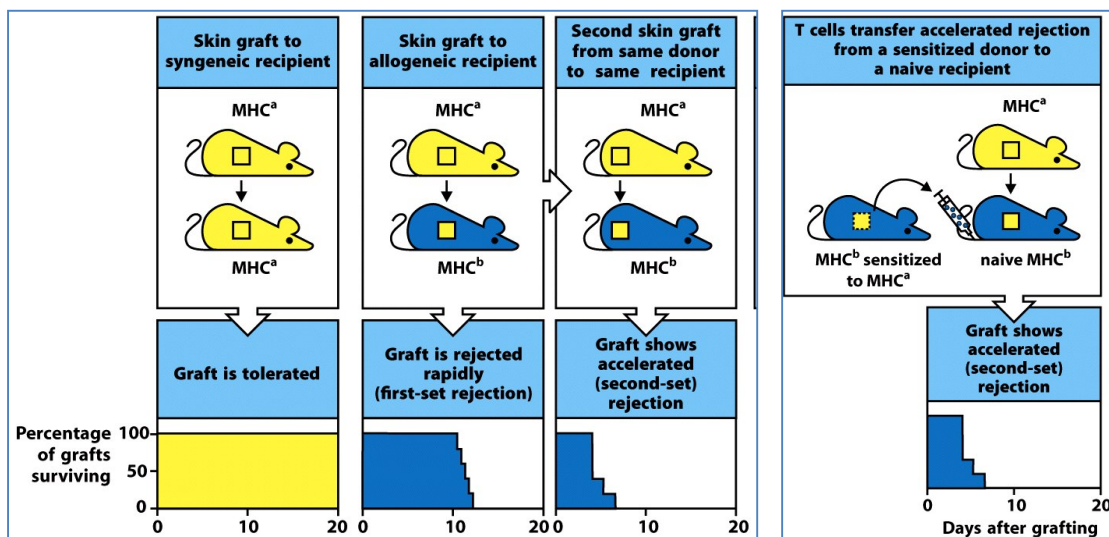
- **Autograft** = The Donor is the Recipient (eg. Skin Grafts)
 - *Syngenic*.
- **Isograft** = Graft between individuals with *Identical MHC* (Ie. Identical Twins)
 - *Syngenic*.
- **Allograft** = Graft between genetically different people.
 - *Allogenic*.



- **Xenograft** = Graft between different *Species*.
 - *Xenogenic*.

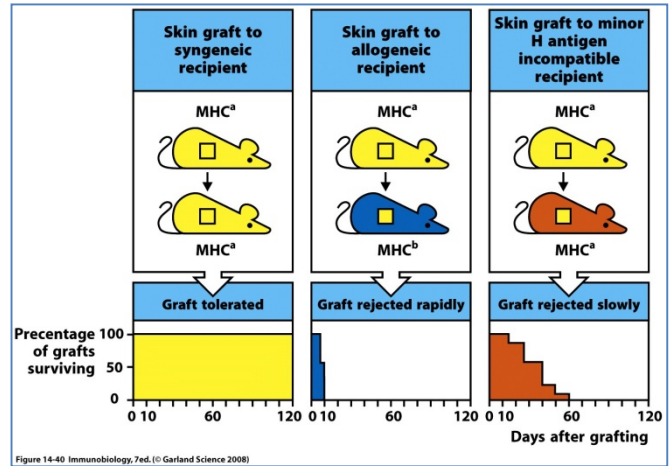
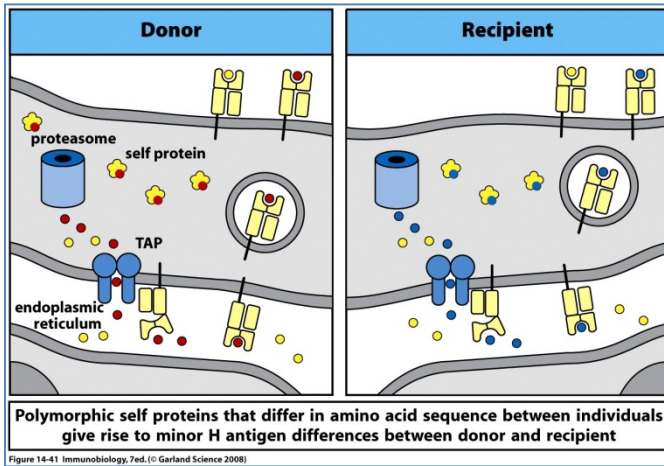
Principles of Transplant Immunology:

- **Alloantigens** = “Antigens that differ between members of the same species.”
 - **NB:** MHC is the most obvious Alloantigen & is the most potent trigger of rejection.
 - **NB:** However, other alloantigens include Minor Histocompatibility Antigens, which are self-proteins which have been broken down into peptides & displayed on MHC-I Molecules.
- **“1st-Set” & “2nd-Set” Graft Rejection:**
 - **1st Set Rejection:**
 - Allogenic graft is given to Unsensitised Individual. (Without Immunosuppressants)
 - Graft is Rejected fairly rapidly once Host Sensitisation has occurred.
 - **2nd Set Rejection:**
 - Allogenic graft from the Same Donor is given to a Pre-Sensitised Individual (Without Immunosuppressants)
 - Graft Rejection is *Accelerated* → Rejection is much more rapid.
 - **(NB: 2nd-Set Rejection is *Specific* – Ie. It will only occur if the Recipient is *Pre-Sensitised* to *That Specific Donor*)**
- **NB: Transfer of “2nd-Set” Rejection by Lymphocyte Transfusion:**
 - Transfusion of Lymphocytes from a Pre-Sensitised Individual to a Naive Individual confers Instant Alloimmunity (2nd-Set Rejection).



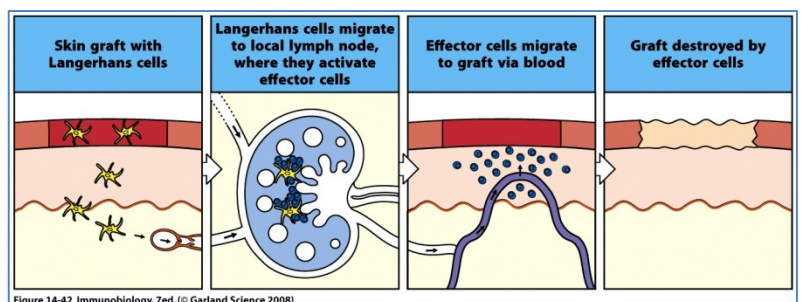
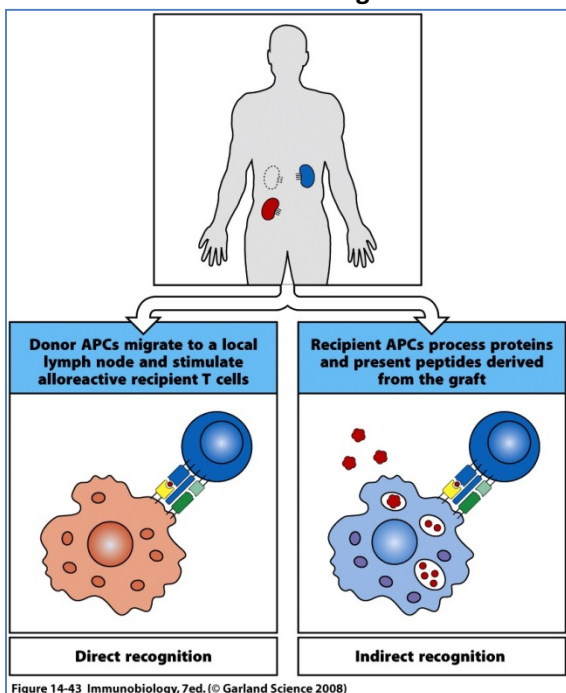
- **Even Matching just the MHC 'Type', Doesn't Guarantee Graft Survival:**

- (I.e. MHC genes may be the same, but other *Minor* Histocompatibility genes may be different.)
- **Minor Histocompatibility Antigens** ('Minor H Antigens') are cell-proteins which have been broken down into peptides & displayed on MHC-I Molecules of all cells.
 - Minor H Antigens will be different between Graft & Host (unless genetically identical).
 - NB: Most minor H antigens are encoded by autosomal genes, & most are unknown.
- **Matching MHC-Type @ the HLA Locus will Prolong Graft Survival, but NOT Guarantee Survival:**
 - See Picture on the Right.



- **"The Alloimmune Response" → 2 Pathways to Rejection:**

- **1. Direct Allorecognition (AKA. Direct Sensitisation):**
 - **NB:** Organ grafts contain APCs of *Donor Origin*.
 - These Donor Dendritic Cells migrate to Local Lymph Node via Lymph & expose their MHC or Minor-H-Antigen → Directly stimulates *Alloreactive* Host T-Cells.
 - (These T-Cells have TCRs specific for the allogenic MHC-I/II:Peptide Complexes)
 - Alloreactive Effector T-Cells are carried back to the graft → Attack the graft directly.
 - **NB: Direct Allorecognition is thought to be largely responsible for Acute Rejection.**
- **2. Indirect Allorecognition (AKA. Indirect Sensitisation):**
 - Uptake & Processing of Allogenic Graft-Proteins by the Host's Dendritic Cells → Presents Peptide bound to self-MHC → Stimulates Ag-specific T.Cells.
 - Alloreactive Effector T-Cells are carried back to the graft → Attack the graft directly.
- **(NB: During the Alloimmune Response, the Regional Lymph Nodes become enlarged due to masses of Proliferating Effector T-Cells.)**



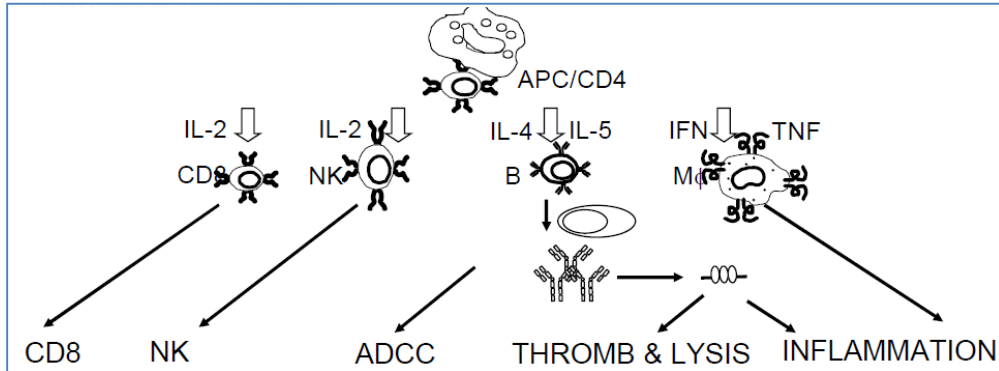
Afferent & Efferent arms of Alloimmune Rejection:

- **Afferent** = Sensitization phase of the immune response (Direct/Indirect Allorecognition)
- **Efferent** = Lymphocytes differentiate into Effector Lymphocytes → Initiate an Immune Response.

The Central Role of T-Cells in Rejection:

- Direct Cytotoxic T-Cell attack on graft cells occurs when the T-Cells recognise the Graft-MHC directly.
- If MHC-Restriction occurs (ie. T-Cells don't properly recognise graft-MHC), the T-Cells may still contribute to Graft-Rejection by:
 - a) Activating Macrophages → Tissue Injury & Fibrosis
 - b) Activating B-Cells to Produce Allo-Antibodies → Ab/Complement -Mediated Graft Destruction.

NB: Although T-Cells are central to Rejection, other things contribute as well:



Rate of Rejection:

Type of rejection	Time	Effector mechanisms
Hyperacute	Min-Hrs	Preformed anti-donor Ab (ABO & MHC) Ab binding to endothelial cells Activation of complement cascade
Accelerated	Days (2-5)	Reactivation of sensitised T cells Cell & humoral immune responses = 2nd set skin graft rejection
Acute	Dys-Wks (7-21Dys)	Activation of naive T cells = 1st set skin graft rejection
Chronic	Mth-Yrs	Multifactorial: Ab, immunocomplexes Tcell activation, immunosuppressants, original disease process

Indications for Clinical Organ Transplantation:

Organ	Indication
Kidney	End stage renal failure
Heart	Terminal cardiac failure
Heart & Lung	Pulmonary hypertension, cystic fibrosis
Liver	Cirrhosis, cancer, biliary atresia
Cornea	Dystrophy, keratitis
Pancreas / islets	Diabetes
Bone marrow	Leukaemia, congenital abnormalities
Small bowel	Cancer
Skin	Burns

Histocompatibility Testing:

- Techniques used in Tissue Typing:

- **Microcytotoxic Assay:**
 - Used to detect presence of Specific-Antibodies against Donor Cells in the Recipient's Serum.
 - How? Donor Cells are incubated with Recipient Serum.
 - If Ab's are present → Complement lysis of donor cells. (Positive Result)
 - If Ab's are NOT present → No Lysis (Negative Result)
- **RFLP - Restriction Fragment Length Polymorphism:**
 - Used to Identify HLA-II (MHC-II) Types at a DNA Level.
- **SBT - Sequence Based Typing:**
 - Used to determine the EXACT Sequence of the HLA Gene.
 - The sequence can be compared to Recipient/Donor to determine Compatibility.
- **PCR-Sequence Specific Oligonucleotide:**
- **PCR-Sequence Specific Primers:**

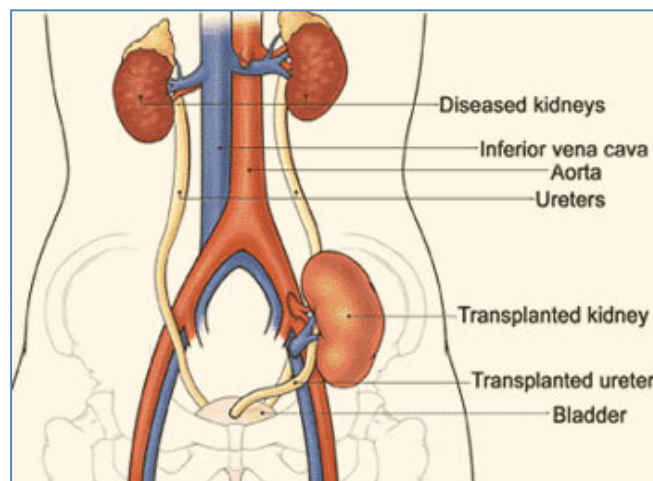
CLINICAL TRANSPLANTATION:

Ischaemic Times:

- **Cold Ischaemic Time:**
 - Begins when the organ is Clamped & Cooled during Removal.
 - Ends when the organ is Returned to Physiological Temperature.
- **Warm Ischaemic Time:**
 - Starts when the organ is Returned to Physiological Temperature.
 - Ends when Surgical Anastomoses are complete → Reperfusion.

Organ Transplant (Eg. Kidney):

- **Indication:**
 - Chronic Kidney Failure
- **Requirements:**
 - **Absolute Requirements:**
 - ABO blood group must be Identical OR Compatible.
 - Negative T-Cell Cross match (I.e. Incubate donor T-Cells with Recipient's Serum → No Reaction)
 - No Previous Antibodies against Donor HLA.
 - No shared incompatibilities with previous donors.
 - **Other Considerations:**
 - Degree of HLA Match
 - Viral Status
 - Previous blood transfusion?
- **Factors Affecting Graft Survival:**
 - *ABO blood group identity
 - *Negative Cross Match
 - *Degree of HLA match
 - **Immunosuppressive Therapy.
- **Complications of Kidney Transplants:**
 - Transplant Rejection (See below)
 - Infections (Due to Immunosuppressant drugs)
 - Post-Transplant Lymphoproliferative Disorder (Eg. Immune Suppressant Induced Lymphoma)
 - Electrolyte Imbalances (Ca/Ph) which can lead to ↓Bone Density.
 - Side Effects of Immunosuppressive Medications.
- **Signs of Kidney Rejection:**
 - **Histological (I.e. By Biopsy):**
 - Abundant Infiltration of Inflammatory Cells in Renal Tubules
 - **Functional:**
 - ↓EPO (Erythropoietin Release) → Anaemia & Hypoxia
 - ↑BP – Due to ↓GFR
 - ↑Uraemia



Bone Marrow Transplant:

- **NB: BM Transplants are dangerous because they require the recipient's bone marrow to be destroyed.**
 - **Therefore, Assessment of Risk/Benefit Ratio is essential.**
- **Indications:**
 - **Any Abnormality of Bone-Marrow (Myeloid) Stem Cells:**
 - Ie. Malignancies (Leukaemia/Lymphomas)
 - Ie. Immunodeficiencies
 - Ie. Acquired Abnormalities (Eg. Thalassaemias/Sickle Cell Disease/Aplastic Anaemia)
- **Requirements:**
 - **HLA Matching:**
 - ****MHC-I/II matching is Essential (To Prevent Graft Rejection or Graft Vs. Host Disease)**
 - This is done by Genetic Techniques to match HLA Genes.
 - **Cross Matching:**
 - Incubate Donor Cells in Recipient Serum.
 - To Determine whether Antibodies in Recipient's Serum will *Cross-React* with Donor Cell Ags.
 - (To Avoid hyperacute rejection)
 - **Mixed Lymphocyte Culture (MLC):**
 - To detect level of reactivity between Donor & Recipient Lymphocytes
 - (Detects subtle differences in MHC-II that aren't detectable by standard techniques)
 - (To Avoid GVHD & Rejection)
- **Considerations:**
 - **Relating to the Disease:**
 - Is it *Curable* by Transplant?
 - Is there an *Alternative*?
 - **Relating to the Procedure:**
 - Recipient Age
 - General Health
 - Infection
 - Donor Availability.
- **(NB: Umbilical '*Cord Blood*' can be used as BM Transplants, because ↑[Stem Cell] & Non-Invasive extraction procedure)**
- **BMT Procedure:**
 - **1. Elimination of Recipient BM Stem Cells:**
 - By High-Dose Chemotherapy/Total-Body Irradiation.
 - Why? – To Eliminate the Pt's *Immune System* → ↓Risk of Graft-Rejection.
 - **2. BM Donation:**
 - 500-1200ml of BM is extracted from donor. (Usually 1st degree relatives)
 - BM Donation is treated with Anti-T-Cell-Antibodies to leave only Stem Cells.
 - OR Umbilical Cord Blood.
 - **3. BM Transplant:**
 - Transfusion of Donor Marrow into Recipient's Bone.
- **Complications of BMT:**
 - **Graft Failure:**
 - Rejection...OR
 - Insufficient # of BM Cells in Post-Transplant Period. (Treated by stimulatory Cytokines)
 - **Infection:**
 - High rates despite preventative measures.
 - **Graft Vs. Host Disease:**
 - Where the Immunologically-Mature Graft Cells *Attack the Host!* (Ie. Reverse Rejection)
 - Can occur even if donor & recipient are HLA-identical because the immune system can still recognise differences in Minor-H-Antigens.
 - Therefore, it is necessary to select donors with a *Similar Genotype* for Minor-H-Ags.
 - Occurs 7-10 days post-op.
 - Symptoms: - Skin Rash/Fever/Hepatosplenomegaly/Bloody Diarrhoea/Breathlessness.
 - 70% Mortality Rate

NB: Graft Vs Leukaemia Effect:

- **Where the Donor T-Cells mount an Immune Response Against Leukaemic Cells.**
 - → Destruction of Recipient Leukaemic Cells → Therapeutic.
- **How to Increase GvL Responses without causing GVHD:**
 - By Adoptive Transfer of T-Cells *Specific* for these Leukaemic-Specific Minor-H-Antigens.

IMMUNE INTERVENTION IN TRANSPLANTATION:

- **Types of Immune Intervention:**

o **Immunosuppression of Recipient:**

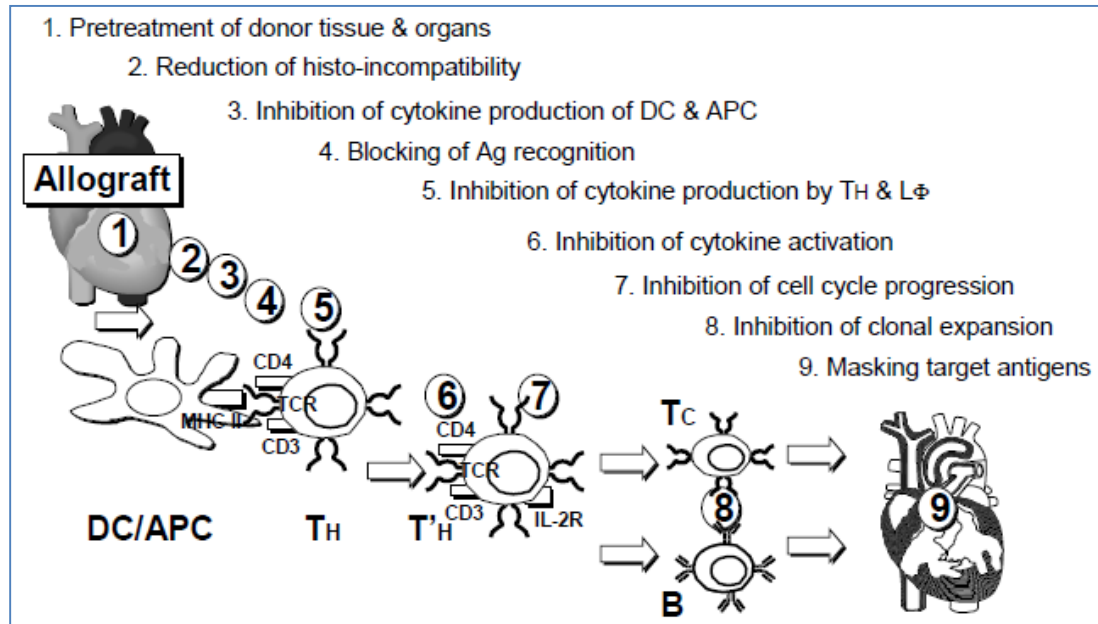
- Most Common
- Currently drugs are *Non-Specific* → *General* Immunosuppression → Immunocompromise.
 - (However, more specific drugs are being developed)
- **NB:** The *Strength* of Immunosuppressants is a fine balance between Rejection & Infection.

Too little	Too much
↑	↓
<ul style="list-style-type: none"> Th cells Tc cells Platelets 	<ul style="list-style-type: none"> Th cells Antibodies Bone marrow
☹️ Rejection	☹️ Infection / Cancer

- o **Induction of Specific Tolerance:**
 - Impossible in humans
- o **Pre-treatment of Allograft Prior to Transplant:**
 - I.e. Removal of Donor APCs from graft tissue

- **Potential Sites for Immunomodulation:**

- o Drug development could target any one of the following processes.



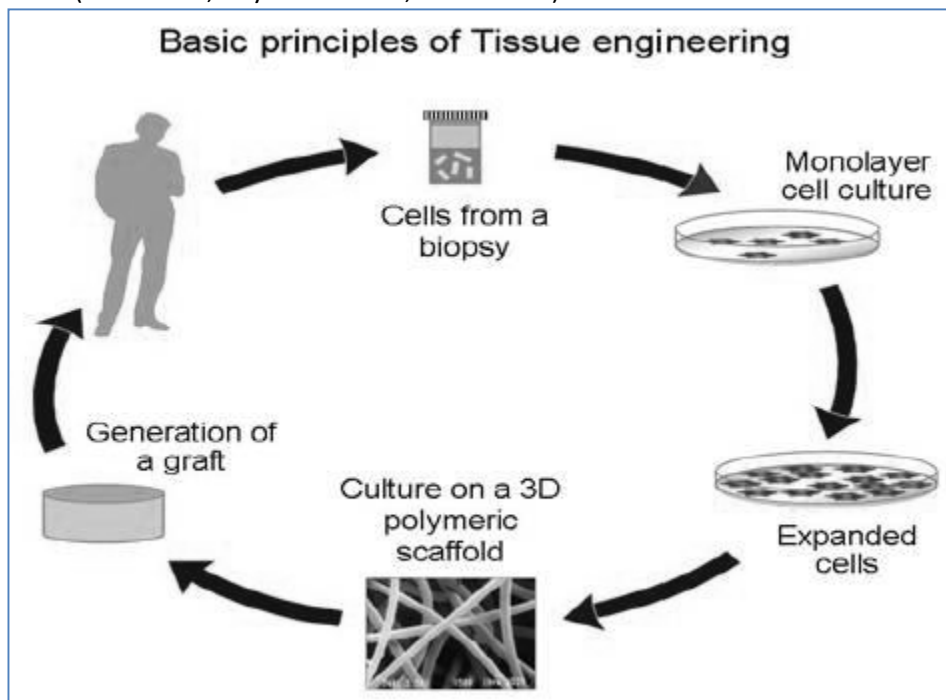
IMMUNOSUPPRESSION:

- **Requirements of Immunosuppressive Agents:**
 - Induction must be at/before *Initial Exposure* to the Allograft.
 - Maintenance to prevent Allograft Rejection
 - Treatment of Rejection Episodes.
- **Current Immunosuppressive Agents:**
 - **Non-Specific:**
 - *Corticosteroids
 - *Cyclosporin
 - Irradiation
 - Cytotoxic Agents
 - Antibodies
 - **Specific:**
 - NONE.
- **Corticosteroids:**
 - (Eg. Prednisone)
 - **Mechanism of Action:**
 - **Anti-Inflammatory Effects:**
 - ↓- Oedema/Cap.Dilation/Angiogenesis/Diapedesis/Phagocytosis/Fibrosis.
 - ***Immunosuppressive Effect:**
 - Inhibit gene transcription for the Inflammatory Cytokines (IL-1 to IL-8), Particularly IL-1 & IL-2 → (↓Antigen-Induced B & T Lymphocyte Proliferation)
 - → ↓Circulating Lymphocytes & Monocytes (Macrophages)
 - → ↓Antigen Presentation
 - **Side Effects:**
 - ↑Risk of Infection
 - Growth Suppression in Children
 - Diabetes
 - Gastric Ulcer
 - Hypertension
 - Cushings Syndrome (Hyper-cortisolism)
- **Cytotoxic Agents (AKA. Cytostatics):**
 - (Primarily used in Chemotherapy for Cancer)
 - **Mechanism of Action:**
 - Blocks DNA Synthesis (S-Phase) → Inhibits Cell Division → Kills Rapidly Dividing Cells.
 - NB: Since Lymphocytes rapidly divide, they are susceptible → Bone Marrow Suppression.
- **Cyclosporin & Tacrolimus:**
 - (A Fungal Metabolite)
 - **Mechanism of Action:**
 - Inhibits IL-2 Receptors → (↓Antigen-Induced Lymphocyte Proliferation)
 - Inhibition of Cytokine Production by Lymphocytes
 - **Side Effects:**
 - Renal Toxicity
- **Antibodies as Immunosuppressants:**
 - **Mechanism of Action:**
 - The aim is to *Inhibit Lymphocyte Function* by giving Abs directed against Lymphocytes.
 - Eg. IL-2-Receptor Antibodies → Inhibit the function of IL-2 Receptors.
 - **Problems:**
 - Selection of Relevant Antigens specific to Lymphocytes.
 - Avoiding Antibodies against blood products.
 - **Monoclonal Antibodies:**
 - Specific Antibodies manufactured to bind to Specific Antigens.

TISSUE ENGINEERING, MAKING TRANSPLANTS REDUNDANT:

Tissue Engineering:

- **What is it?**
 - Engineering tissues to Replace/Restore Organ Function.
 - Growing Artificial Tissue Within a Patient; Or In Vitro→Transplanted.
- **Target Tissues Include:**
 - Pancreas
 - Bladder
 - Cartilage
 - Airway
 - Skin
 - Bone Marrow
- **3 Main Components:**
 - **Cells:**
 - Cells extracted from target organ (incl. Stem Cells & Genetically Engineered Cells)
 - **Scaffolds:**
 - Form the desired 3D structure of the tissue for the Cells to Grow Onto.
 - Biodegradability is essential.
 - **Culture Medium:**
 - Must meet Metabolic Requirements of Cells (O₂, pH, Humidity, Temp, Nutrients)
 - Depending on specific tissue, may require Factors/Stimuli for proper functionality (Hormones, Physical Stimuli, Blood Flow)

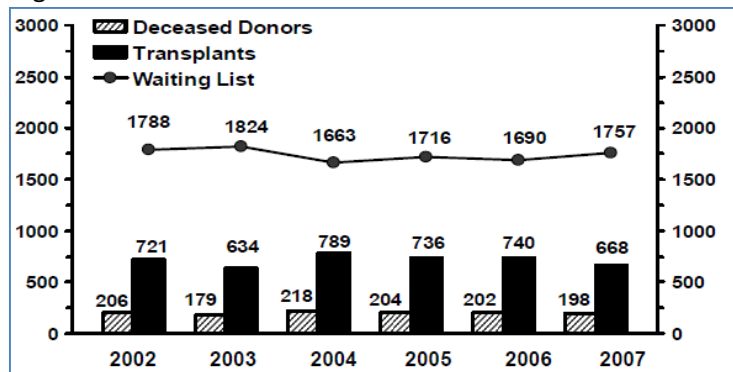


Organ Donation & Ethics:

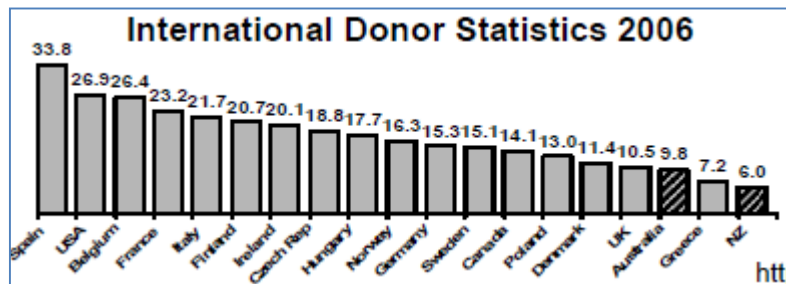
- Transplantation Statistics:

○ Waiting List > Transplants > Deceased Donors:

- NB: Why are there more transplants than donors? – Because 1x donor can donate multiple organs.



○ Australia is one of the *Worst* Donor Countries in the World.



○ 5-Year Graft Survival Rates:

- Range from $\approx 40\%$ to $\approx 70\%$ depending on the organ/tissue transplanted.
- (Kidneys tend to last the longest – Probably due to better ‘matching’ since its non-urgent)

- For More, See Integrative Session Enclosed:

IMMUNOLOGY Pathology: INFLAMMATION

General Features of Inflammation:

- **What is it?**
 - The complex reaction of Vascularised Tissue to Injury/Microbes.
- **5 Cardinal Signs:**
 - Pain (Dolor)
 - Red (Rubor)
 - Swelling (Tumor)
 - Heat (Calor)
 - Loss of Function
- **What is its Purpose?**
 - The Body's First *Active* Defence against Invading Microbes.
 - Neutralize
 - Destroy
 - Limits the Spread of Harmful Agents.
 - Sets the stage for *Tissue-Repair*.
- **Major Players in Inflammation:**
 - **Vessels:** (Endothelial Cells)
 - **Connective Tissue Cells Involved:**
 - Mast Cells (Histamine Release)
 - Fibroblasts (Scarring & Tissue Repair)
 - Macrophages (Phagocytosis & Cytokine Secretion)
 - Lymphocytes (Cell-Mediated & Humoral Immunity)
 - **Blood Cells Involved:**
 - Monocytes (→ Macrophages)
 - Neutrophils (Phagocytosis)
 - Eosinophils (Parasitic Infections & Allergy)
 - Basophils (Allergy)

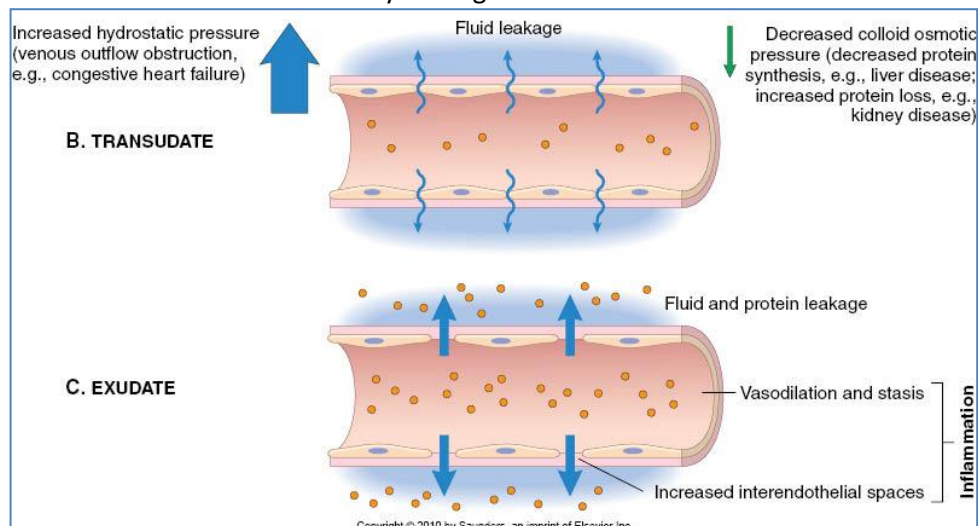
Acute Vs. Chronic Inflammation:

- **Acute Inflammation:**
 - I.e. Minutes/hours/days after Trigger.
 - **Primary Characteristics:**
 - Vasodilation → ↑ Blood Flow
 - *Exudation* (Fluid & Plasma Protein accumulation in local tissues)
 - *Neutrophil Migration* (into tissues)
- **Chronic Inflammation:**
 - I.e. Weeks→Years after Trigger. (Or Continuous trigger)
 - **Primary Characteristics:**
 - High Numbers of Inflammatory Cells:
 - Macrophages
 - Lymphocytes
 - Angiogenesis.
 - Fibrosis
 - Necrosis

The Primary Inflammatory "Responses" (**Vasoactivity & Leukocyte Migration):

- Vasoactivity:

- - **Vasodilation:**
 - Increase in Vascular Calibre → ↑ Blood Flow
 - **Mechanism:** Relaxation of Vascular Smooth Muscle
- - **&/OR ↑ Vascular Permeability:**
 - Structural Changes in Endothelium → Allows Plasma Proteins & Leukocytes to Leave the Circulation.
 - **Mechanism:** By Endothelial Cell Contraction → Creates Gaps Between Cells.
- **Triggered By:**
 - ****Histamine** (Directly), or Indirectly by Histamine-Releasing Factors:
 - Platelet-Activating Factor (PAF):
 - Bradykinin
 - Nitric Oxide
- **Effects:**
 - ↑ Blood Flow
 - → ↑ Mucus Production
 - Transudate (Leakage of Fluid from Circulation → Tissues)
 - Exudate (Leakage of Fluid, Cells & Plasma Proteins from Circulation → Tissues)
 - → Easier Leukocyte Emigration from Blood → Tissues.



- Leukocyte Migration:

- **Effects:**
 - **↑ WBCs in Extravascular Space:**
 - Neutrophils/Eosinophils/Basophils
 - Macrophages
 - Lymphocytes
 - **↑ Cell-Mediated Immune Responses**
 - Innate – Granulocytes/Macrophages
 - Adaptive – Lymphocytes & NK-Cells

RHEUMATOLOGY Pathology:
ANTI-RHEUMATOID DRUGS

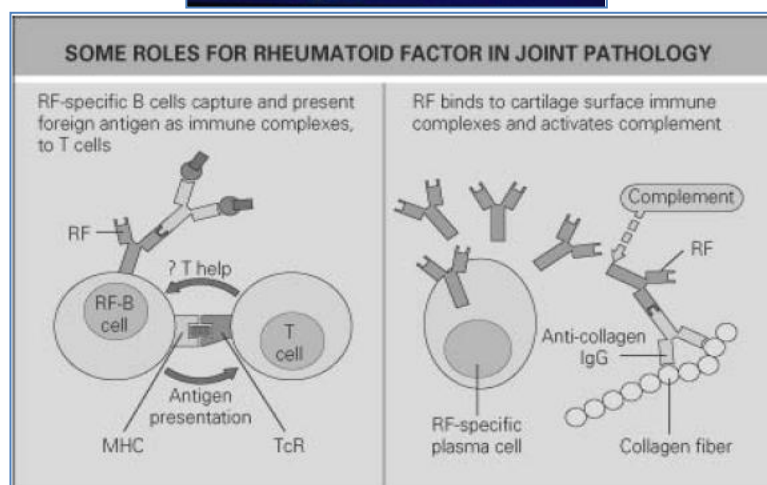
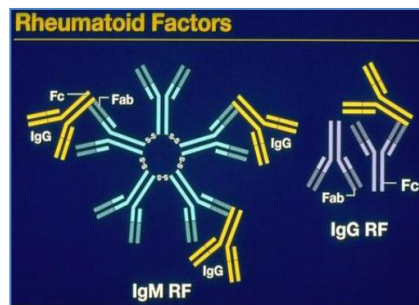
- **Corticosteroids & Rheumatoid Arthritis:**

○ **What is Rheumatoid Arthritis?**

- An Autoimmune Condition marked by Chronic Inflammation of Joint Connective Tissue due to Deposition of Rheumatoid Factor Complexes.

○ **Main Pathophysiology of Rheumatoid Arthritis:**

- ****Autoantibodies called Rheumatoid Factors are generated (Aeitiology unknown) and Accumulate in Joint Tissue →**
 - **→Inflammation Via Inflammatory Mediators (Bradykinins, Prostaglandins, Cytokines).**
 - →Vascular Changes in Joint → Accumulation of Immune Cells.
 - →Phagocytosis of Immune Complexes
 - →Release of Enzymes → Attack Joint Tissues.
 - →Free Radical Production
 - **→→JOINT DAMAGE.**
- **NB: Both Humoral Responses & Cell-Mediated are thought to play a part:**
- (Therefore Type -IV & -III hypersensitivities involved)
 - **CD4-Th-Cells → Activate Macrophages → Release Cytokines (TNFa, IL-1 & IL-6) → Inflammation:**
 - →↑Production of Rheumatoid Factors (IgM Anti-IgG-Abs) by RF-B-Cells.
 - →Activate Osteoclasts → Bone Erosion
 - →→Joint Destruction.
 - **Plasma Cells → Secrete Rheumatoid Factors (IgM Anti-IgG-Antibodies) → Immune Complexes →Deposition in Joints & Periphery.**
 - (NB: Systemic Complications are due to peripheral deposition of Immune Complexes)
 - **RF:IgG Complexes in Articular Cartilage →**
 - →Complement Activation → Lysis of Chondrocytes
 - →Opsonisation of Chondrocytes → Phagocytosis/Cytotoxic Killing.



○ **Treatment: Anti-Rheumatoid Drugs:**

- **Corticosteroids – (Steroidal Anti-Inflammatory):**

- → ↓Cytokine Secretion → ↓Inflammation
- → Immunosuppression.
- **NSAIDs – (Non-Steroidal Anti-Inflammatories):**
 - → Symptomatic Relief
- **DMARDs – (Disease-Modifying Anti-Rheumatic Drugs):**
 - (Mild Chemotherapy drugs, used due to their *Immunosuppressive* 'Side-Effects'.)
 - Eg. Methotrexate (an Antimetabolite) → Inhibits folate-dependent DNA Synthesis → Inhibits Lymphocyte Proliferation.
 - Eg. Leflunomide (an Antimetabolite) → Inhibits Pyrimidine Synthesis.
 - Eg. Cyclosporin – Inhibits IL-2 Receptors → (↓Antigen-Induced Lymphocyte Proliferation)
- **Biological Drugs:**
 - Direct inhibitors of Pro-Inflammatory Cytokines:
 - TNF α Inhibitors
 - IL-1 Inhibitors
 - IL-6 Inhibitors
 - Inhibitors of T-Cell Co-Stimulation.

Autoimmunity

Concepts Behind Autoimmune Diseases:

- General Info:

- **Autoimmune Diseases = “Specific, Adaptive Immune Responses Against Self Antigens”:**
 - Autoimmune responses *resemble* normal immune responses to pathogens → Give Rise to:
 - Specific Autoreactive Effector Cells
 - Specific Autoreactive Antibodies (Autoantibodies).
- 2/3 are Female
- **There are many Autoimmune Disease Manifestations:**
 - **Some are ‘Organ-Specific’** – (Because some Ags are specific to certain organs):
 - Eg. Type 1 Diabetes Mellitus
 - Eg. Multiple Sclerosis
 - Eg. Myasthenia Gravis
 - **Some are ‘Organ Non-Specific’** – (Because many Ags are expressed on multiple organs):
 - Eg. Rheumatoid Arthritis
 - Eg. Systemic Lupus Erythematosus
- **Type II, III & IV Hypersensitivity Reactions may be involved.**
- **NB: The Presence of Autoantibodies is Not Always Harmful** – (Because there is an extra ‘level’ of control – Exerted by T-Cells; i.e. ↓T-Cell Help → ↓Antibody Levels)

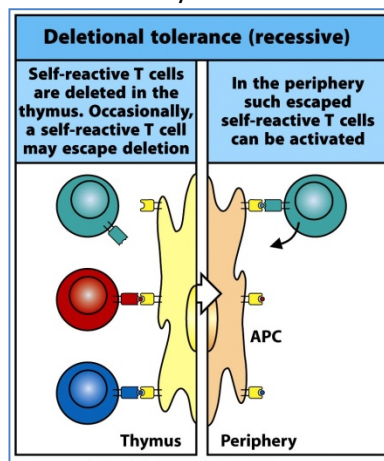
- Autoreactive T & B-Cells:

- **Both T & B-Cells are Involved in the Autoimmune Process:**
 - **Autoreactive T-Cells:**
 - → Cell-Mediated Destruction of Tissues expressing Self-Antigen.
 - **Autoreactive B-Cells:**
 - → Humoral Immunity (Abs) against Self-Antigen.
- **But How???**
 - Gene rearrangement during lymphocyte development in the Primary Lymphoid Organs is **Random**, and thus inevitably results in *some lymphocytes* with affinity for Self-Antigens.
 - These Autoreactive Lymphocytes are normally Removed/Inactivated by a variety of mechanisms → Self-Tolerance.
 - **However, Autoimmunity is a Failure of these mechanisms of Self-Tolerance.**

Revision of Tolerance Mechanisms – How they Normally Prevent Autoimmunity:

- Central (‘Thymic’) Tolerance:

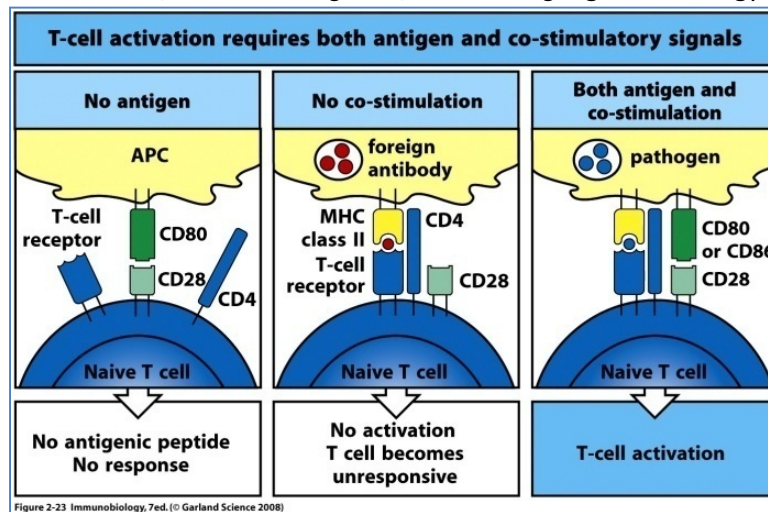
- **Elimination of Self-Reactive Lymphocytes in the Thymus:**
 - Many (But not all) of the body’s Self-Antigens are expressed in the Thymus/Bone Marrow by a subset of Dendritic-Like Cells → Delete Strongly-Autoreactive Lymphocytes.
- **- However, Some Self-Reactive Lymphocytes Escape Elimination.**
 - These Lymphocytes leave the Thymus & can be Activated to cause Autoimmune Disease.



- **Peripheral Tolerance:**

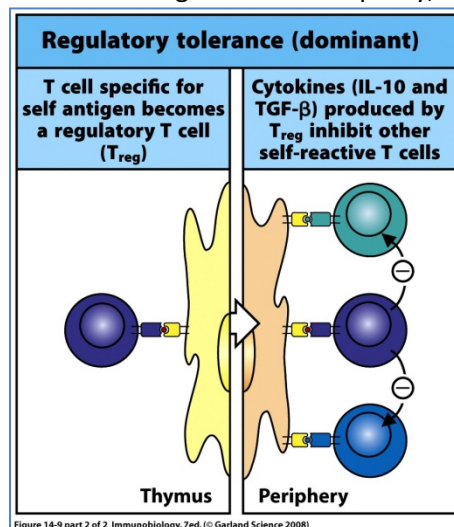
○ **Energy (& Lack of Co-Stimulation):**

- Relies on the Innate Immune System to Signal Infection → Permits the Adaptive Immune System to be Activated:
- In the *Absence* of infection, these signals are not generated.
- In such circumstances, Interactions between a Naive Lymphocyte with Self-Antigen, *without* Co-stimulation, leads to a *Negative, Inactivating* Signal → Anergy.



○ **Regulatory Tolerance:**

- (I.e. Suppression induced by Regulatory-T-Cells.)
- T_{Reg}-Cells develop in the Thymus in response to *Weak Stimulation* by *Self-Antigens*.
- → If they encounter Self-Antigens in the Periphery, they Secrete Inhibitory Cytokines.



○ **Ignorance:**

- (I.e. Self-Antigens are “invisible” to the immune system)
- Some lymphocytes with Relatively Low Affinity for Self-Antigens make *No Response* to them and are considered ‘*Ignorant of Self*’.
- - However, these *Ignorant but Latently Self-Reactive* cells can be recruited if the stimulus, (Eg. Infection), is strong enough.
 - Eg. Naive Self-Reactive *Ignorant* T-Cells become activated by a Dendritic Cell presenting Self-Antigen + High Levels of Co-Stimulatory signals.

○ **Separation of Autoreactive T-Cells and Self-Antigens:**

- Antigens may be located in ‘*Immunologically Privileged*’ Sites.
- (Eg. Brain & Anterior chamber of the Eye.)

PATHOGENIC MECHANISMS OF AUTOIMMUNE DISEASES:

Contributing Factors:

Genetic Factors:

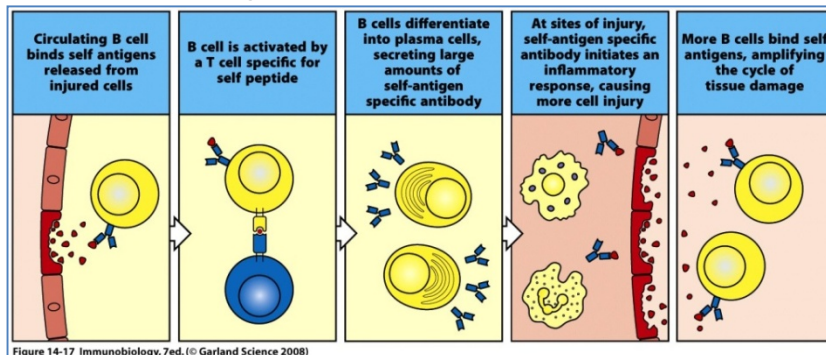
- Some individuals are Genetically Predisposed to Autoimmunity.
- Autoimmune diseases are more common in females than males.
- Some Autoimmune diseases (eg. Type 1 Diabetes) run in families.
- Scientists have isolated several Single-Gene traits associated with Autoimmunity.

Environmental Factors:

- Eg. SLE will only occur in *Both* Identical Twins around 25% of the time. Therefore, Environmental Variables must be at play.

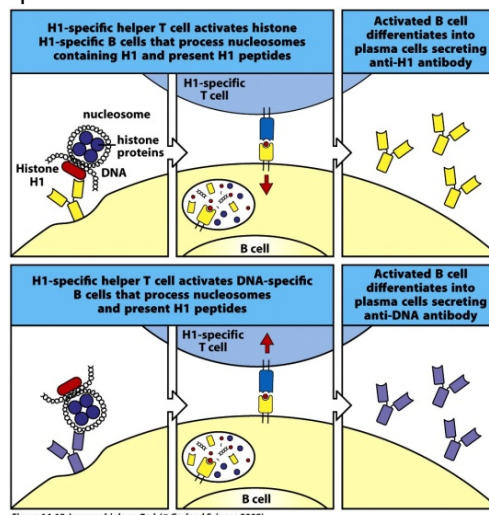
Exposure of Hidden Epitopes → Chronic Inflammation → Perpetuates Autoimmunity:

- (NB: Some antigens are not normally exposed – However, following Trauma/Disease, these antigens may be exposed → Formation of Auto-Antibodies → Chronic Inflammation.)
- 1. Cell damage releases self-antigens → Specific Circulating B-Cells may bind to these Self-Antigens.
- 2. APCs may ingest & present these Self-Antigens to specific CD4-T-Cells → Active Effector Th-Cells.
 - Active Effector Th-Cells → Activate Specific B-Cells.
- 3. Specific B-Cells differentiate into Plasma-Cells → Secrete Self-Ag-Specific Antibody.
- 4. Antibodies attack the sites of injury → Causing an Inflammatory Response → Further Cell Injury.
- 5. Further Cell Injury → ↑Release of Self Antigens → More B-Cells binding to Self-Antigens.
 - → Potentiates Tissue Damage.



“Epitope Spreading” Amplifies Autoimmunity:

- Epitope Spreading occurs when an Autoreactive B-Cell endocytoses & processes a specific antigen, and then Presents the Antigen-Derived Peptides to T-Cells.
- However, Processing of Antigens reveals previously hidden Epitopes → Therefore, a variety of T-Cells will be activated by that B-Cell.
- These Autoreactive T-Cells then provide help to multiple subsets of B-Cells → Production of a Greater Variety of Autoantibodies.
- (Eg. In SLE (Lupus), Autoreactive T-Cells specific to Histones, provide help not only to the original Histone-Specific B-Cells, but also DNA-Specific B-Cells → Production of both Anti-Histone & Anti-DNA antibodies)



MHC & Autoimmune Disease:

- **NB: There is a Tendency for Autoimmune Diseases to “Run in Families” – HLA Genes (MHC) are Involved:**
 - o **Different HLA Types are Associated with different Autoimmune Diseases:**
 - For Most Autoimmune Diseases, MHC-II is mostly implicated. (Some are MHC-I)
 - o **Many Autoimmune Diseases are Linked to Certain MHC Alleles:**
 - Eg. Siblings with an Autoimmune Disease are likely to *also* share the Same MHC Haplotypes.

Infectious Agents can Induce Autoimmune Diseases:

- **How? – By Providing an Environment that Promotes Lymphocyte Activation:**
 - o → ↑Inflammatory Mediators from APCs & Lymphocytes.
 - o → ↑Expression of Co-Stimulatory Molecules on APCs.
 - o → Tissue Destruction → ↑Availability of the Self-Antigen.
- → APCs presenting Self-Antigen can activate Autoreactive T-Cells (Incl. Ignorant T-Cells).
 - o → Autoimmune Disease.

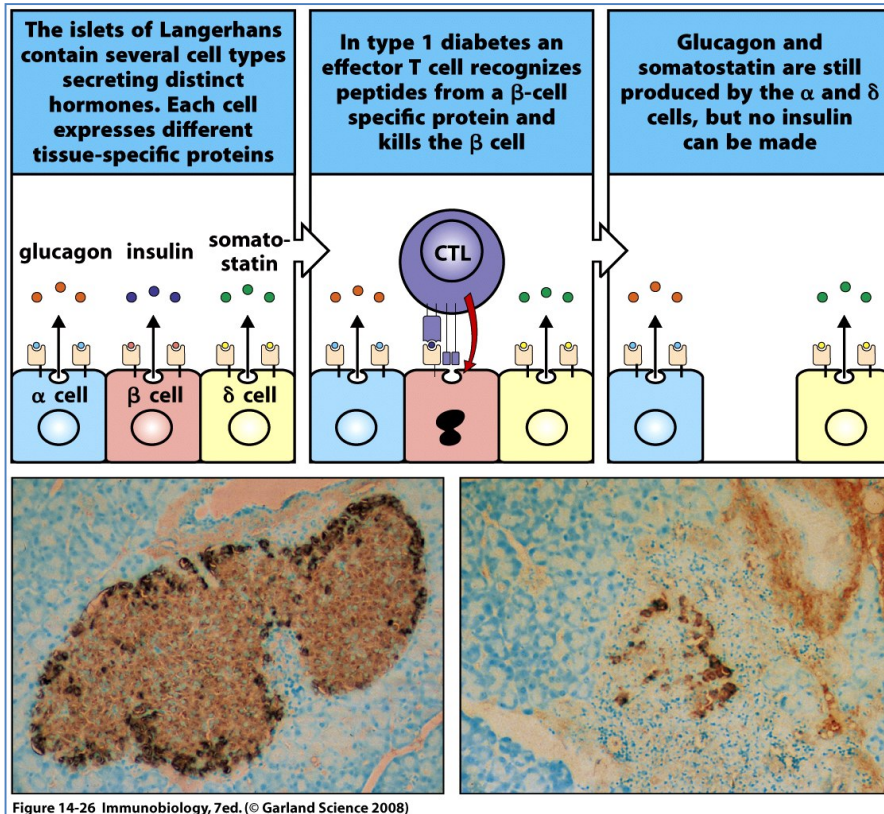
Cross-Reactivity with Micro-Organisms – (Molecular Mimicry):

- Some Pathogens express Antigens that resemble Host Molecules – (Molecular Mimicry).
- → Stimulate Adaptive Immune Response:
 - o → B-Cells secrete Antibodies that may cross-react with self protein.
 - o → T-Cell attack on self tissues.
- → Autoimmune Disease.
- (Eg. Rheumatic Fever – Similarity of Epitopes on Strep. Antigens (eg. M-Protein) and Host Cardiac Tissue → Causes Antibody-Mediated damage to a variety of tissues (Incl. Heart Valves/Myocardium))
- (Eg. Antibodies to Epstein-Barr Virus may react with Myelin → Multiple Sclerosis)
- **Background Info on Group-A-Strep (GAS):**
 - o **As a Normal Flora:**
 - ***Strep. Pyogenes* is one of the most frequent pathogens of humans.**
 - ≈5-15% of people harbour the bacteria (Respiratory Tract) – Asymptomatic.
 - There are ≈120 Strains – Some more rheumatogenic than others.
 - **Can Infect when Immunocompromised** → Pharyngitis/Cellulitis/Fasciitis/Toxic Shock.
 - **However, ‘Rheumatic Strains’ Can Also Cause Autoimmune Diseases** → Post-Strep Glomerulo-Nephritis/ Acute Rheumatic Fever (→ Rheumatic Heart Disease)
 - o **‘Rheumatogenic’ GAS:**
 - **‘Rheumatic Strains’ Can Cause Autoimmune Diseases:**
 - Eg. Rheumatic Fever (→ Rheumatic Heart Disease)
 - Eg. Post-Streptococcal Glomerular Nephritis
 - Eg. Reactive Arthritis (NB: NOT Rheumatoid Arthritis)
 - **NB: The degree of “Rheumatogenicity” depends on the concentration of M Proteins.**
 - o **Immunogenic Virulence Factors:**
 - **GAS produces a wide array of Virulence Factors:**
 - ****M-Protein** (Antiphagocytic, & Anti-Complement)
 - ***Exotoxins** (*Superantigens → Toxic Shock, *Pyrogens & Mitogens)
 - ***Invasins (Streptolysin)** (Lysis of RBCs/WBCs & Release of Lysosomal Enzymes)
 - ***DNAse** (Depolymerises free DNA)
 - **The Importance of ‘M-Protein’ in RHD:**
 - The M-Protein Antigen is remarkably similar to Cardiac Myosin (in Heart Muscle)
 - → Stimulates an Adaptive Immune Response → Anti-M-Protein Antibodies.
 - o Anti-M-Protein Antibodies *Cross-React* with Cardiac Myosin →
 - → Valvular Thickening
 - → Thickening/Fusion of Chordae Tendoneae
 - → Diffuse fibrosis
 - → Focal Fibrinoid Necrosis

Organ-Specific Autoimmune Diseases To KNOW:

Type 1 Diabetes Mellitus:

- **What is it?**
 - Deficiency of Insulin leading to Abnormalities in Glucose Utilisation by Insulin-Dependent Tissues.
- **Aetiology:**
 - Deficiency in Insulin due to CD8-Mediated Autoimmune Destruction of β -Cells in the Islets of Langerhans in the Pancreas.
- **Genetics:**
 - NB: Type1 Diabetes is strongly linked to Mutations in the HLA-DQ Genotype.



Myasthenia Gravis:

- **What is it?**
 - MG is an Antibody-Mediated Autoimmune Disease which attacks the ACh-Receptors @ the NMJ, leading to Failure of Neuromuscular Transmission.
 - **How? By 3 Mechanisms:**
 - A) Complement Binding & Activation @ the NMJ
 - B) 'Antigenic Modulation'
 - C) Functional AChR-Block by Antibodies (Relatively Rare)
- **Treatment:**
 - **Acetyl-Cholinesterase Inhibitors:**
 - Drugs that Inhibit the Cholinesterase Enzyme from degrading ACh in the Synapse.
 - \rightarrow Prolonged Action of ACh in the Synapse
 - $\rightarrow \uparrow$ [ACh] in the Synapse

Multiple Sclerosis:

- **What is it?**
 - Autoimmune Destruction of the Myelin Sheaths of Axons in the CNS.
 - (I.e. Strips the brain's 'wires' of 'insulation')
 - NB: 'Myelin Basic Protein' (MBP) Seems to be the targeted antigen.

Hashimoto's Thyroiditis:

- **What is it?**
 - Autoimmune Destruction of the Thyroid Gland:
 - Antibodies against Thyroid Peroxidase &/or Thyroglobulin → Destruction of Thyroid Follicles.
 - Strongly linked to the HLA-DR5 Gene.
- **Symptoms:**
 - Often Presents as Hypothyroidism
 - Weight Gain
 - Depression
 - Sensitivity to Heat/Cold
 - Fatigue
 - Others.

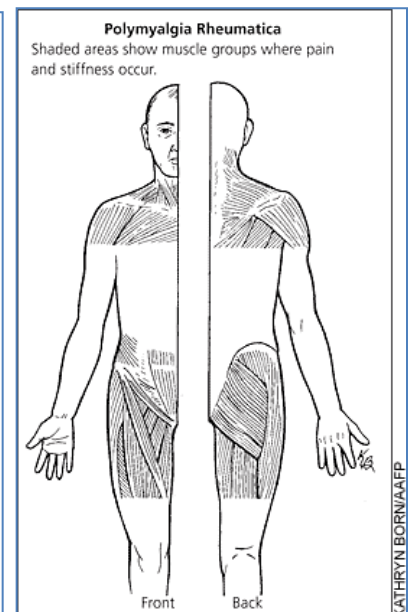
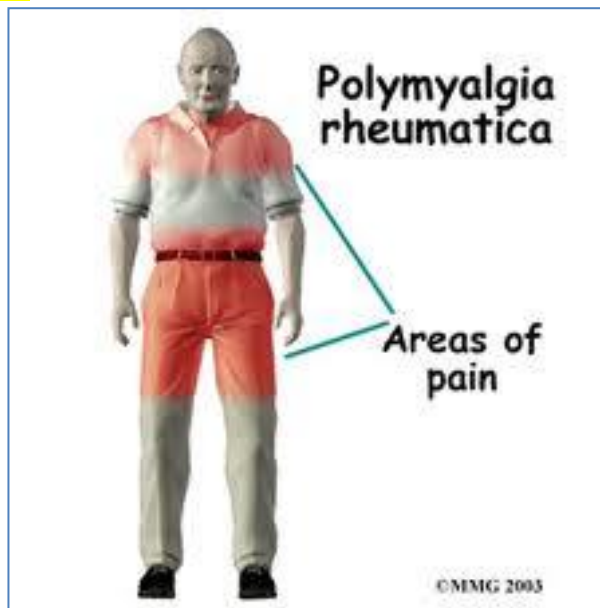
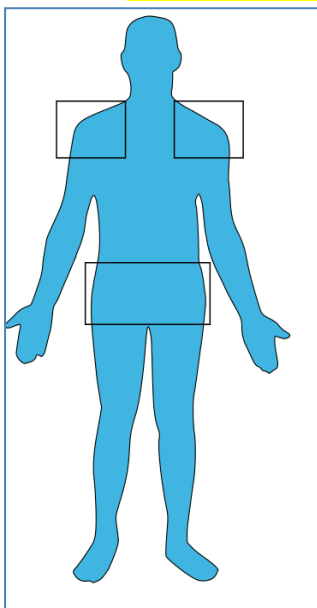
Graves' Disease:

- **What is it?**
 - An Autoimmune disease where the Thyroid is Enlarged & Overactive → Excessive Thyroid Hormones.
 - Due to Autoantibodies against the TSH-Receptor → Activate TSH-Receptor → Stimulate Thyroid Hormone Synthesis/Secretion.
 - →Hyperthyroidism.

MUSCULOSKELETAL Pathology:
POLYMYALGIA RHEUMATICA

POLYMYALGIA RHEUMATICA (PMR):

- **Aetiology:**
 - o **Unknown**
 - o Association with Giant-Cell Arteritis (Temporal Arteritis – [A Vasculitis])
 - o + Genetic (HLA-DR4) Susceptibility
 - o + Possible Viral Trigger (Parvovirus, Parainfluenza Virus, Adenovirus)
- **Pathogenesis:**
 - o Autoimmune Attack on the Joints & Muscles
- **Clinical Features:**
 - o Older Females – (2F:1M, >50yrs)
 - o **Severe Symmetrical Myalgia** (Not Arthralgia) of Proximal Extremities (Shoulder/Pelvic Girdle)
 - + Muscle Tenderness, BUT NO Weakness or Atrophy.
 - Myalgia Worst in Mornings
 - o + **Constitutional Symptoms** – (Fever, Weight Loss, Fatigue, Anorexia, Anaemia, Malaise)
- **Diagnosis:**
 - o >50yrs
 - o >2 Muscle Groups Affected
 - o Elevated ESR & CRP
 - o Responsive to Corticosteroids
 - o NB: **NORMAL Creatinine Kinase**
- **Treatment:**
 - o **Corticosteroids**



Non Organ-Specific Autoimmune Diseases To KNOW:

Rheumatic Fever & Rheumatic Heart Disease:

- **What is it?**
 - = A Complication of GAS infection characterised by Inflammatory changes in the Heart:
 - → Activation of T-Cells
 - → Activation of B-Cells → Antibodies against M-Protein (& Cardiac Myosin).
 - → Damage to Heart Valves &/or Muscle.
- **GLS Question - What is the difference between Rheumatic Fever (RF) & Rheumatic Heart Disease (RHD)?**
 - (NB: Neither RF or RHD is an Infection, and *Both* can affect the Heart.)
 - (The Distinction is whether it is *Reversible* (RF) or *Irreversible* (RHD).)
 - **Rheumatic Fever:**
 - An acute, *Post*-GAS-Infection Inflammatory Disease.
 - Occurs a few weeks *After* a GAS Infection.
 - If not treated aggressively → Acute Rheumatic Carditis → Valvular Deformities.
 - **Rheumatic Heart Disease:**
 - The Chronic Stage which causes Irreversible Myocardial Damage & Heart Valve Damage.

Clinical Features & Diagnosis – “The Revised Jones Criteria”:

- = Evidence of Prior Strep Infection + 1x Major *OR* a Few Minor Manifestations:

One major or a few minor manifestations
+
Evidence of previous GAS infection

- **Major Manifestations:**
 - Carditis – (Inflammation of the Heart)
 - Erythema (Erythematous Rash) – (pink rings on the trunk, arms &/or legs) – due to immune complexes depositing in the Vessels.
 - Polyarthritits
 - Chorea – (spasmodic movements of the body and limbs)
 - Subcutaneous Nodules
- **Minor Manifestations:**
 - Fever
 - Prolonged PR-Interval (Cardiac Fibrosis → Disruption in the Heart’s Conduction Pathway)
- **Lab Tests:**
 - Presence of Anti-Strep Antibodies – (Definitive)
 - Elevated ESR (Erythrocyte Sedimentation Rate) – (Non-Specific Inflammatory Marker)
 - Elevated CRP (C-Reactive Protein) – (Non-Specific Inflammatory Marker)
 - Anti-DNA Antibodies.



- **Aetiology – (Role of Group-A-Strep (GAS) in Rheumatic Heart Disease):**

- (NB: For Background Information on GAS, see section on 'Cross-Reactivity with Micro-Organisms')
- **The Main Point:**
 - Rheumatic Heart Disease is a *Consequence* of the lasting, *Cross-Reactive, Adaptive Immune Response* to a Previous GAS Infection.



○ **Immunogenic Virulence Factors:**

▪ **GAS produces a wide array of Virulence Factors:**

• ****M-Protein** (Antiphagocytic, & Anti-Complement)

- *Exotoxins (*Superantigens → Toxic Shock, *Pyrogens & Mitogens)
- *Invasins (Streptolysin) (Lysis of RBCs/WBCs & Release of Lysosomal Enzymes)
- *DNAse (Depolymerises free DNA)

▪ **The Importance of 'M-Protein' in RHD:**

- The M-Protein Antigen is remarkably similar to Cardiac Myosin (in Heart Muscle)
- → Stimulates an Adaptive Immune Response → Anti-M-Protein Antibodies.
 - Anti-M-Protein Antibodies *Cross-React* with Cardiac Myosin →
 - → Valvular Thickening
 - → Thickening/Fusion of Chordae Tendoneae
 - → Diffuse fibrosis
 - → Focal Fibrinoid Necrosis

- **Treatment:**

○ **Eradication Treatment:**

- Antibiotic Treatment to treat the Initial Strep Infection & prevent the *Development* of RF.
- If commenced within 9 days of onset → Prevents progression to Acute Rheumatic Fever.

○ **Secondary Prophylaxis:**

- Long-Term Antibiotic Treatment to prevent Re-Infection → Prevents progression to RHD.

MUSCULOSKELETAL Pathology:
RHEUMATOID ARTHRITIS

RHEUMATOID (AKA: "Seropositive") ARTHRITIS (Commonest):

- **Aetiology:**
 - o Genetic Autoimmune
- **Pathogenesis:**
 - o Genetic (HLA-DR4 & -DR1 Genes) → Rheumatoid Factor Production (Anti-IgG Ab) → Autoimmune
 - o → Macrophage-Mediated Local Joint Inflammation & Destruction
- **Morphology:**
 - o Erosion of the Articular Cartilage down to the bone.
 - o Pannus – Inflamed thickened hyperplastic synovium with *papillary projections*
 - (NB: Normal synovium is very thin and smooth and shiny)
 - o Fibrous Ankylosis (Bone Fusion)



- **Clinical Features:**
 - o Chronic, Multisystem Condition
 - o Onset Age: 20-40yrs
 - o **Symmetrical, POLY-arthritis, with Morning Stiffness.**
 - Particularly MCP & PIP Joints of the Hand
 - "Morning Stiffness" – (As with all Inflammatory Arthroses)
 - Joint Crepitus
 - o Signs:
 - "Swan-Neck Deformity" – (Ulnar Deviation & Subluxation of the MCP Joints)
 - Ankylosis - (Fusion) & Restriction of movement → Muscle Wasting
 - Dermatologic - Rheumatoid Nodules (eg. Elbows)
 - Vasculitis - Digital Infarcts (can cause gangrene)
 - Ophthalmologic - Dry eyes, Scleritits
 - Pulmonary - Fibrosis, lung nodules, pleuritis, effusion
 - Cardiac - pericarditis, pericardial effusion, valvular defects, conduction defects
 - GI - PUD (from NSAIDS), dry mouth
 - Renal - Amyloidosis --> Proteinuria
 - Hepatic - Nodules (Nodular regenerative hyperplasia), portal fibrosis
 - Neurologic - Cervical spine instability, peripheral nerve entrapment
 - Haematologic - Lymphadenopathy, splenomegaly and leukopenia, amyloidosis, anaemia.

- **Diagnosis:**

- o Diagnostic Criteria:

Requires 4 ⁺ of the Following Features for Diagnosis:
▪ Morning Stiffness
▪ >3 Joints
▪ MCP/PIP/Wrist Joints.
▪ Symmetrical Arthritis
▪ Rheumatoid Nodules in Skin
▪ RA Seropositivity (Rheumatoid Factor in Serum)
▪ X-Ray Changes: Erosions



- o Lab:

- Old - Serum Rheumatoid Factor Positive (Anti-IgG IgM Antibodies) –Hence "Seropositive"
- New – ACCP – ("Anti-Cyclic Citrullinated Peptide Antibody Test) 95% Specificity
- + Elevated ESR

- **Treatment:**

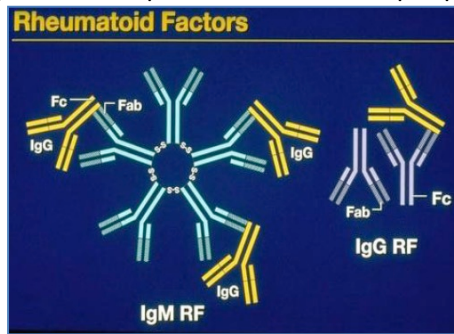
- o DMARDS – (**Methotrexate, Sulfasalazine**)
- o NSAIDs - For Symptomatic Control
- o Corticosteroids: Short-term adjuvants.

Rheumatoid Arthritis:

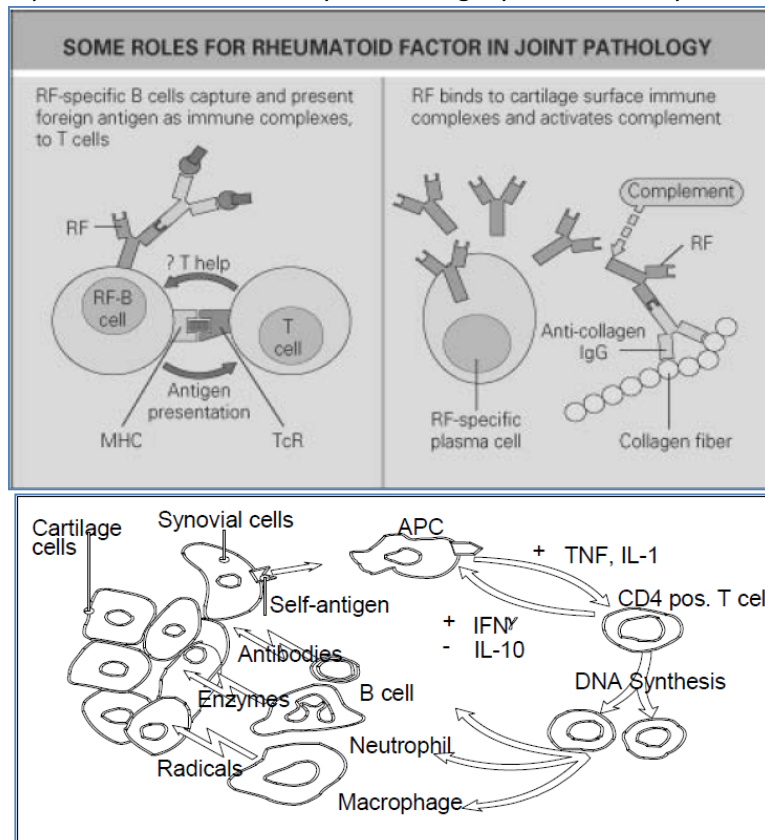
- **What is it?**
 - **Autoimmune Destruction of the Joint Cartilage & Inflammation of the Synovium.**
 - → Infiltration of Granulocytes, CD4-Th-Cells, Macrophages & Plasma cells into the synovium.
 - Peak onset ≈ 55yrs.
 - F:M (3:1)
 - NB: *Rheumatoid Factors* are present in 70% of all Rheumatoid Arthritis Pts. – (A Diagnostic Test)
- **Articular Features:**
 - Inflammation in joints
 - Joint pain & Swelling
 - Bony Malformation (Deformities)
 - Functional disability
- **Extra-Articular Features:**
 - Dermatologic - Rheumatoid Nodules (eg. Elbows), & Vasculitis
 - Ophthalmologic - Dry eyes, Scleritis
 - Pulmonary - Fibrosis, lung nodules, pleuritis, effusion
 - Cardiac - pericarditis, pericardial effusion, valvular defects, conduction defects
 - GI - PUD (from NSAIDS), dry mouth
 - Renal - Amyloidosis --> proteinuria
 - Hepatic - Nodules (Nodular regenerative hyperplasia), portal fibrosis
 - Neurologic - Cervical spine instability, peripheral nerve entrapment
 - Haematologic - Lymphadenopathy, splenomegaly and leukopenia, amyloidosis, anaemia.
- **Clinical Features & Diagnosis:**
 - **Early Stages:**
 - Morning Stiffness
 - 3/more joints.
 - *Smaller Joints* of Hands/Feet.
 - Bilateral Symmetric Distribution.
 - *Positive* Rheumatic Factor.
 - Rheumatoid Nodules
 - Intrinsic Muscle Wasting
 - ↑*ESR/CRP*
 - 
 - **Established Disease:**
 - Typical *Ulnar-Deviation* of fingers.
 - Erosions (seen in x-rays)
 - 
 - **Serological Tests:**
 - ***Anti-Citrullinated Protein Antibody (ACCP).**
 - Visible up to 10yrs before onset of disease.
 - Can discriminate between RA & Arthritic-SLE.
 - Test for Rheumatoid Factors.
 - Erythrocyte Sedimentation Rate (ESR) – Non Specific
 - C-Reactive Protein (CRP) – Non Specific

Aetiology:

- ****Autoantibodies called Rheumatoid Factors are generated (Aetiology unknown) and Accumulate in Joint Tissue →**
 - **→ Inflammation Via Inflammatory Mediators (Bradykinins, Prostaglandins, Cytokines).**
 - **→ Vascular Changes in Joint → Accumulation of Immune Cells.**
 - **→ Phagocytosis of Immune Complexes**
 - **→ Release of Enzymes → Attack Joint Tissues.**
 - **→ Free Radical Production**
 - **→ → JOINT DAMAGE.**
- **NB: Both Humoral Responses & Cell-Mediated are thought to play a part:**
- (Therefore Type-III & -IV hypersensitivities involved)
 - **CD4-Th-Cells → Activate Macrophages → Release Cytokines (TNF α , IL-1 & IL-6) → Inflammation:**
 - **→ Potentiate Production of Rheumatoid Factors (IgM Anti-IgG-Abs) by RF-B-Cells.**
 - **→ Activate Osteoclasts → Bone Erosion**
 - **→ → Joint Destruction.**
 - **Plasma Cells → secrete Rheumatoid Factors (IgM Anti-IgG-Antibodies) that bind to the Fc-Portion of IgG Antibodies → Forms Immune Complexes → Deposition in Joints & Periphery.**
 - (NB: Systemic Complications are due to peripheral deposition of Immune Complexes)



- **Binding of RF:IgG Complexes to Articular Cartilage →**
 - **→ Complement Activation → Lysis of Chondrocytes**
 - **→ Opsonisation of Chondrocytes → Phagocytosis/Direct Cytotoxic Killing.**



- **Treatment:**

- (NB: Since Tissue Injury occurs due to an Inflammatory Response, Meds aim to Decrease/Stop this.)
- **NSAIDs:**
 - (COX Inhibitors) → ↓Prostaglandin Synthesis → ↓Pain & ↓Inflammation.
- **DMARDs:**
 - (Disease Modifying Anti-Rheumatic Drugs) – Mild Chemotherapy drugs, used due to their *Immunosuppressive* 'Side-Effects'.
 - Eg. Methotrexate (an Antimetabolite) → Inhibits folate-dependent DNA Synthesis → Inhibits Lymphocyte Proliferation.
 - Eg. Sulfasalazine.
 - Eg. Hydroxychloroquine - ↓Acidity of lysosomes.
 - Eg. Leflunomide (an Antimetabolite) → Inhibits Pyrimidine Synthesis.
 - Eg. Cyclosporin – Inhibits IL-2 Receptors → (↓Antigen-Induced Lymphocyte Proliferation)
- **Corticosteroids:**
 - A General Immunosuppressant → ↓Cytokine Secretion & ↓Immune Cell Activity.
- **Biological Drugs:**
 - Direct inhibition of Pro-Inflammatory Cytokines:
 - TNF α Inhibitors
 - IL-1 Inhibitors
 - IL-6 Inhibitors
 - Inhibition of T-Cell Co-Stimulation.
- **Monoclonal Antibodies**
 - Against Osteoclasts.
 - Against B-Cells
 - Against Pro-Inflammatory Cytokines.

Systemic Lupus Erythematosus (SLE):

- What is it?

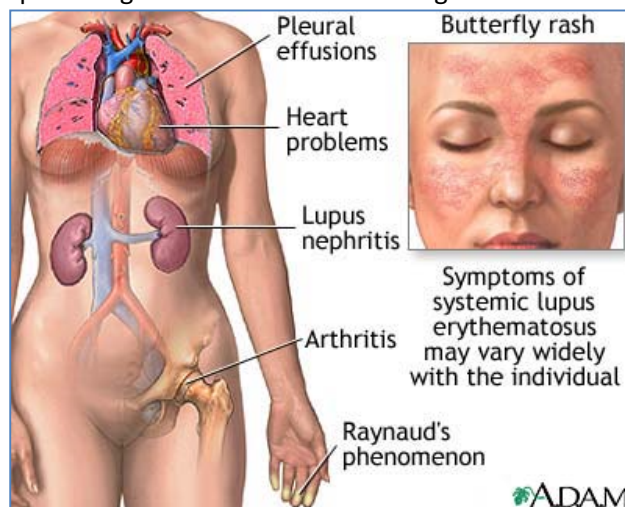
- **Chronic Multi-System Autoimmune Disease.**
- ***Characterised by Many Different Anti-Nuclear Antibodies:**
 - * Anti-DNA
 - Anti-Ribonucleoprotein
 - Anti-Histone
 - (NB: Autoantibodies may attack directly or form Immune-Complexes → Disease)
- **F:M (10:1)**

- Manifestations:

- Skin Rash
- Arthritis
- Glomerulonephritis
- Haemolytic Anaemia
- Thrombocytopaenia
- CNS Involvement

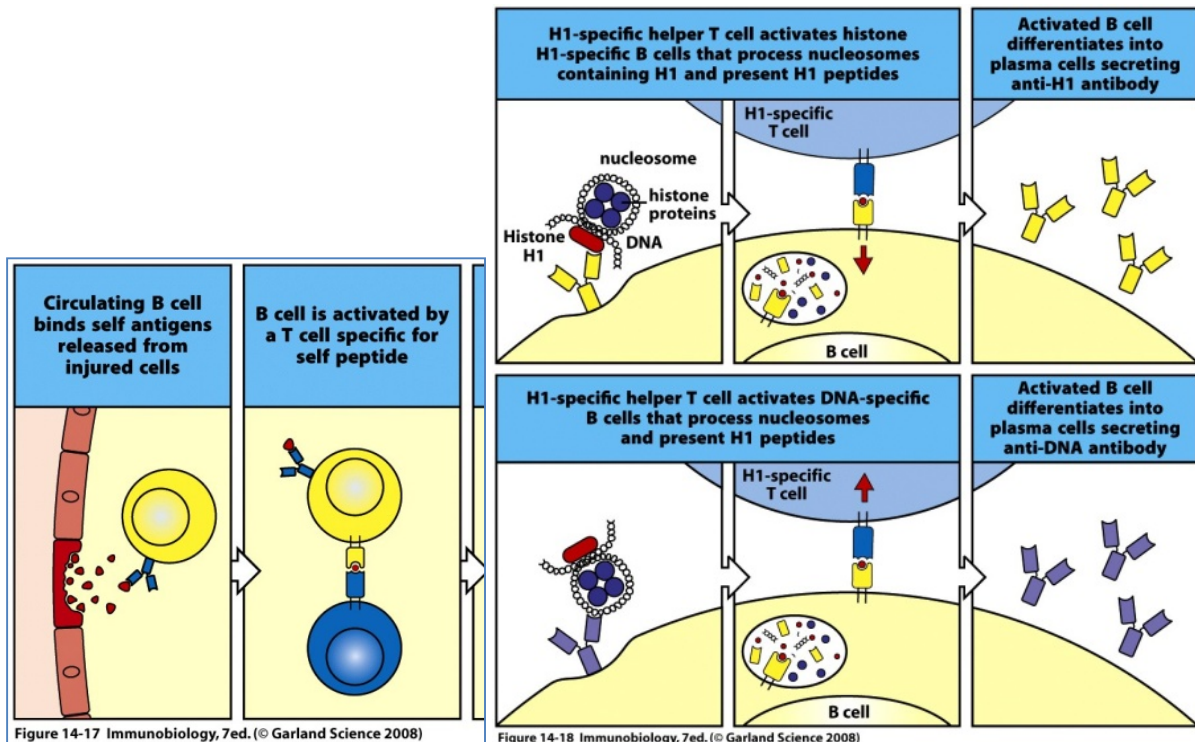
- Diagnostic Criteria:

- Malar Rash (Scaly, Red, Butterfly-Shaped rash on face)
- Disc-like rash
- Photosensitive Rash
- Oral Ulcers (Or in Nasal Cavity)
- Arthritis (Non-erosive)
- Serositis – (Eg. Pleuritis or Pericarditis)
- Renal Disorders – (Eg. Glomerulonephritis, Proteinuria, Cellular Casts)
- Neurological Disorders – (Eg. Seizures/Psychosis)
- Haematological Disorders – (Eg. Haemolytic Anaemia, Leukopaenia, Thrombocytopaenia)
- Antinuclear Antibody Test – Positive.
- **Serological Tests:**
 - **Antinuclear Antibody (ANA) Test** – (95% of SLE Pts are ANA positive):
 - The hallmark of systemic autoimmunity
 - However, not specific to SLE. (ENA test required for definitive diagnosis)
 - **Extractable Nuclear Antigens (ENA):**
 - Once presence of ANAs have been determined, ENAs are used to determine the specific Ag that the ANAs are binding to in the nucleus.



- **Pathogenesis:**

- ***SLE is Caused by Presence of Different Anti-Nuclear Antibodies – So How are they formed?:**
 - **Epitope Spreading:**
 - (Autoreactive T-Cells specific to Histones, provide help not only to the original Histone-Specific B-Cells, but also DNA-Specific B-Cells → Production of both Anti-Histone & Anti-DNA antibodies)
 - 1. A Damaged/Apoptotic cell releases Nuclear Material.
 - 2. An Autoreactive Histone-Specific B-Cell binds, endocytoses, and present it to Autoreactive CD4-Th-Cells – (Incl. Those specific to *other* Nuclear Antigens. – Eg. DNA-Specific)
 - 3. The Histone-Specific T-Cells then help DNA-Specific B-Cells → Produce Anti-DNA Antibodies, which form complexes with Nucleosomes and Complement protein C3.
 - 4. These complexes then deposit in the kidneys → Cause Glomerulonephritis.
- **NB: Some Genetic Predisposition**
- Deficiency of Fas Ligand → Failure to remove Autoreactive T-Cells by Apoptosis.



Treatment of Autoimmune Diseases:

- Immunosuppressive Drugs – Most Common:

Therapeutic approaches to treating autoimmunity	
Genetic/pathogenic pathway	Strategy
Co-stimulatory molecules	B7 blockade (CTLA-4-Ig) CD40L blockade (anti-CD40L) BAFF blockade (soluble receptor or antibody)
T _{reg}	Induction of self-antigen-specific T _{reg} clones for infection
Antigen clearance	Immune complex removal DNase to break up chromatin in SLE
Antigen presentation/ autoantibody secretion	B-cell depletion (with anti-CD20)
Cytokine polarization	Cytokine treatment Oral tolerization to induce cytokine deviation
Inflammatory mediators	Blockade of TNF- α (soluble receptor or antibody)

NEUROLOGICAL Pathology: HUNTINGTONS DISEASE

- Huntingtons Disease:

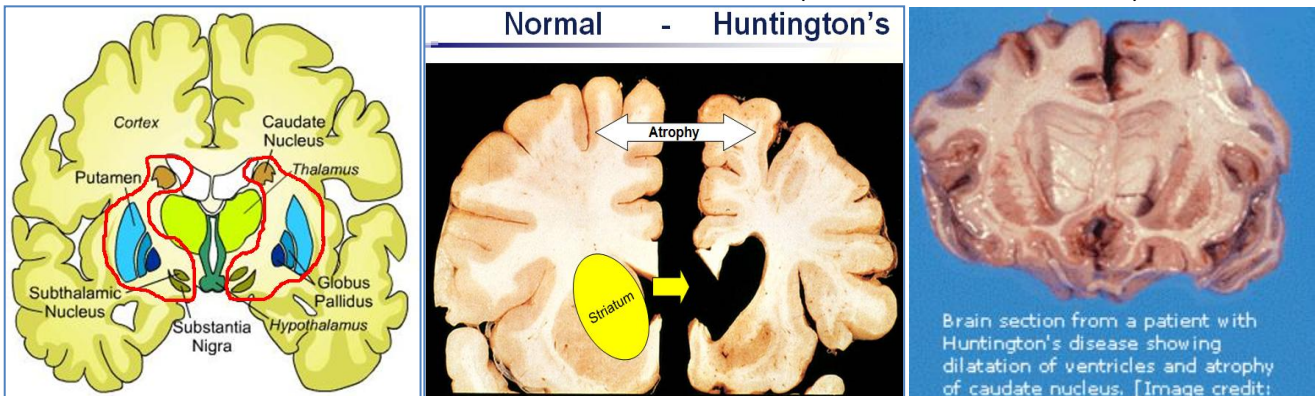
○ **Aetiology:**

- **Genetic - Autosomal Dominant**
- Defective Huntington Gene (Chromosome 4) – Excess CAG Tandem Repeats
- Onset Age & Severity depends on # of CAG Repeats in mutation.

5' -GAT-ATG-AGG-CAG-CAG-CAG-CAG-CAG->>>-3' 3' -CTA-TAC-TCC-GTC-GTC-GTC-GTC-GTC-GTC-TTA-5' (Asp-Met-Arg-Gln-Gln-Gln-Gln-Gln-Leu)	NORMAL REPLICATION	No. Repeats	Median age of onset
		39 repeats	66 yrs
		40 repeats	59 yrs
		41 repeats	54 yrs
		42 repeats	49 yrs
		43 repeats	44 yrs
		44 repeats	42 yrs
		45 repeats	37 yrs
		46 repeats	36 yrs
		47 repeats	33 yrs
		48 repeats	32 yrs
		49 repeats	28 yrs
		50 repeats	27 yrs

○ **Pathogenesis:**

- Excess CAG Tandem Repeats in Huntington Gene → Production of Mutant Huntingtin Proteins in the Brain → Increases *Decay Rate* of Certain Types of Neurons →
 - → **Selective Marked Degeneration of the Basal Ganglia (incl. The Striatum [Caudate + Putamen], Globus Pallidus & Substantia Nigra).**
 - NB: Loss of Basal Ganglia → Dysfunctional Action Selection → Chorea
 - → **Also loss of Cortical Tissue as well** (Dementia as well as chorea)



○ **Morphology:**

▪ **Macro:**

- Atrophy of Basal Ganglia (Striatum [Caudate & Putamen], Globus Pallidus & Substantia Nigra)
- Some Atrophy of Cortical Tissue as well.
- Compensatory Hydrocephalus of Lateral Ventricles (Lateral Ventricular Dilatation)

○ **Clinical Features:**

- Onset in 40's (NB: The more CAG repeats, the younger the onset & faster the progression)
- **Huntington's Triad:**
 - Dementia (Intellectual Decline)
 - Depression
 - Coreiform Movement (Involuntary Jerking) → Unsteady Gait
- **Late Stages:**
 - Slurred speech
 - Difficulty swallowing.

○ **Treatment:**

- Incurable
- Tetrabenazine, Neuroleptics, Benzodiazepines Can → ↓Chorea

○ **Prognosis:**

- <20yr life expectancy after Symptoms Begin.

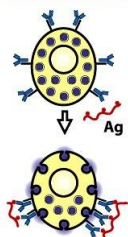
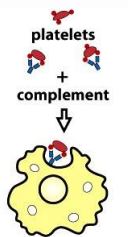
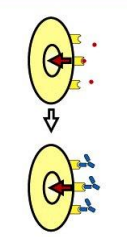
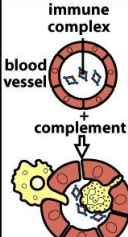
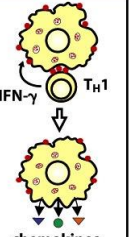
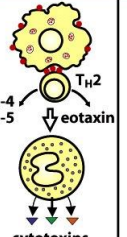
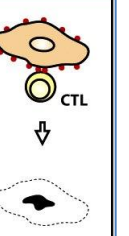
IMMUNOLOGY Pathology: HYPERSENSITIVITIES

Hypersensitivity:

- = an *Abnormal state of Immune Reactivity with Deleterious Effects* on the Host.
- (Atopy = "Hypersensitivity Tendency (usually IgE-Mediated) against Innocuous Substances)

There are 4 Types of Hypersensitivity:

- I - Anaphylactic
- II – Antibody Dependent Cytotoxicity
- III – Immune Complex
- IV – Cell Mediated Disease

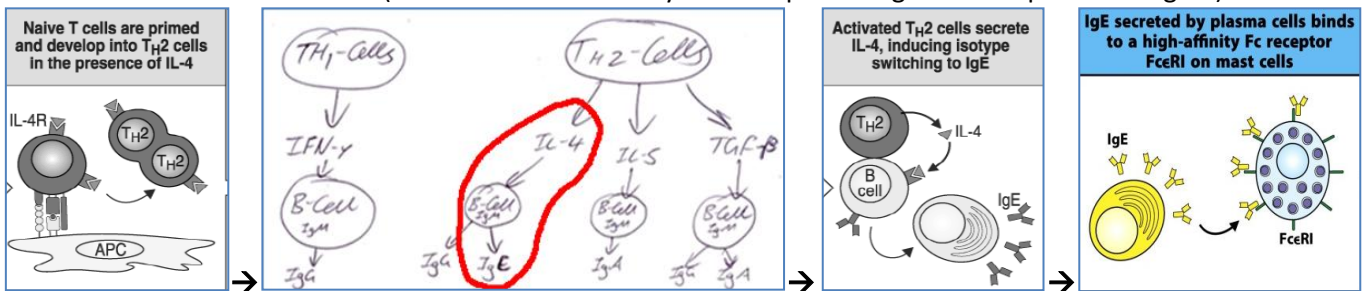
	Type I	Type II		Type III	Type IV		
Immune reactant	IgE	IgG		IgG	TH1 cells	TH2 cells	CTL
Antigen	Soluble antigen	Cell- or matrix-associated antigen	Cell-surface receptor	Soluble antigen	Soluble antigen	Soluble antigen	Cell-associated antigen
Effector mechanism	Mast-cell activation	Complement, FcR ⁺ cells (phagocytes, NK cells)	Antibody alters signaling	Complement, phagocytes	Macrophage activation	IgE production, eosinophil activation, mastocytosis	Cytotoxicity
							
Example of hypersensitivity reaction	Allergic rhinitis, asthma, systemic anaphylaxis	Some drug allergies (e.g. penicillin)	Chronic urticaria (antibody against FcεR1α)	Serum sickness, Arthus reaction	Contact dermatitis, tuberculin reaction	Chronic asthma, chronic allergic rhinitis	Graft rejection

HYPERSENSITIVITY REACTIONS			
Type I	Reactant: IgE Antigen: soluble Ag Effector: mast cells	⇒	Rhinitis Asthma Anaphylaxis
Type II	Reactant: IgG Antigen: cell / matrix Ag Effector: FcR ⁺ cells	⇒	Drug allergies
Type III	Reactant: IgG Antigen: soluble Ag Effector: FcR ⁺ cells + complement	⇒	Serum sickness
Type IV	Reactant: TH1 Antigen: soluble Ag Effector: macrophage	⇒	Contact dermatitis Tuberculin test
	Reactant: TH2 Antigen: soluble Ag Effector: Eosinophil	⇒	Chronic asthma Allergic rhinitis
	Reactant: CTL Antigen: Cell-assoc. Ag Effector: Cytotoxicity	⇒	Contact dermatitis

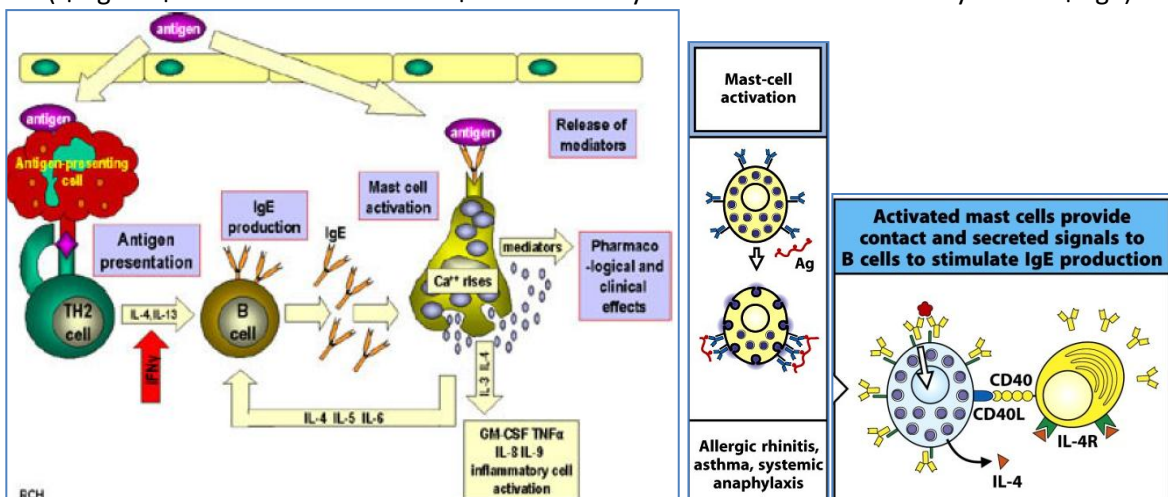
} Delayed

TYPE-I HYPERSENSITIVITY:

- **(Anaphylaxis/Allergy) - IMMEDIATE**
- **- A Function of Th2-Cells, IgE-Antibodies & Mast Cells:**
 - o Eg. Anaphylaxis.
 - o Eg. Atopic Asthma
 - o Eg. Rhinitis
 - o Eg. Urticaria (Hives)
- **Mechanism:**
 - o **Rapid immune reaction to a Previously-Sensitised Antigen**
 - o **- Antigen is Re-Exposed to a sensitized Mast-Cell/Basophil → Degranulates IgE-Bound ‘Mast Cells’:**
 - → Releasing Inflammatory Mediators of Type-1-Hypersensitivity Reactions.
 - o **Sensitization:**
 - 1. Allergen enters the body.
 - 2. APCs Presents the Allergen to Ag-Specific Th2-Cells
 - (NB: Allergens preferentially stimulate a Th2-Cell response → Drives IgE production)
 - 3. Th2-Cells → Activate Ag-Specific B-Cells to secrete IgE (**Via IL-4, IL-13 + Co-Stimulation**)
 - (Remember that Ig-Switching from IgM to IgE is Mediated by IL-4 from Th2-Cells.)
 - 4. B-Cells Produce **IgE**-Antibodies against the Allergen.
 - 5. Fc-Portion of IgE-Antibodies attach to *High-Affinity-Fc-Receptors* on Mast-Cells.
 - (Ie. Mast cells effectively become primed against the specific allergen.)



- o **Re-Exposure:**
 - 6. Re-Exposure of Antigen → Antigen binds Antibody on Mast-Cell → Mast-Cell Degranulates:
 - → Releases Inflammatory Mediators → Vasodilation & Smooth Muscle Contraction.
 - o Mediators Include:
 - Histamine
 - Leukotrienes
 - Prostaglandins
 - → Releases **IL-4** → **Potentiates & Amplifies IgE Production** by Plasma Cells.
- (↑ IgE = ↑ Mast cell Activation = ↑ Inflammatory Mediators & Inflammatory cells = ↑ IgE)

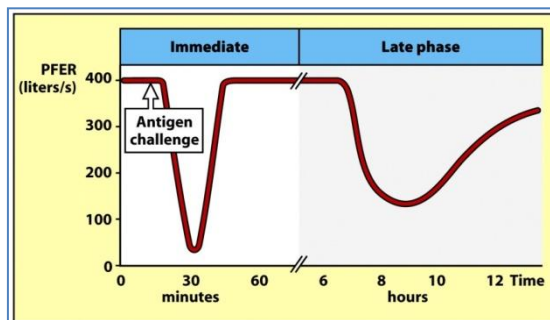


- **Mast Cells in Type-I Hypersensitivity:**

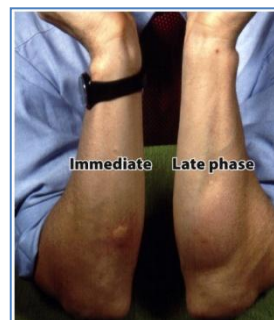
- Mast Cells line **Body Surfaces** → Alert the immune system to local infection.
- Have **High-Affinity Fc-Receptors** → Allow mast cells to bind Ag-Specific IgE Antibodies.
- Binding of Ag to IgE:FcRs → **Degranulation** of basophilic granules.
- **Molecules Released in Degranulation:**
 - ****Histamine:**
 - Vasodilation
 - ↑Vascular Permeability
 - **Bronchial Smooth Muscle Contraction.**
 - ****IL-4:**
 - Stimulates & Amplifies Th2-Cell Response.
 - ***Prostaglandins & Leukotrienes** → **Trigger further Histamine Release** →:
 - Vasodilation
 - ↑Vascular Permeability
 - Bronchial Smooth Muscle Contraction
 - ↑Mucus Secretion.
 - **TNFα:**
 - Proinflammatory Effects
 - Activates Endothelium.
 - **CCL3 Chemokine:**
 - Attracts Phagocytes (Monocytes, Macrophages & Neutrophil).

- **Allergic Responses are 'Bi-Phasic' – (Immediate- & Late- Phase Responses in Allergy):**

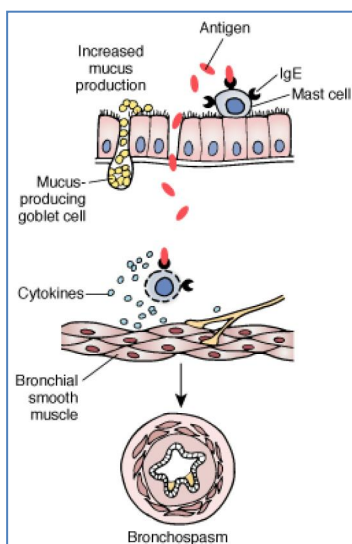
- **Immediate Phase Response:**
 - Occurs within seconds of Exposure.
 - Due to *Release of Preformed* Mediators by Mast-Cells. (I.e. Histamine, Prostaglandins)
- **Late Phase Response:**
 - Occurs 8-12hrs after Exposure → Oedema.
 - Due to *Synthesis* of Mediators by Mast-Cells. (I.e. Cytokines, Leukotrienes & Chemokines)



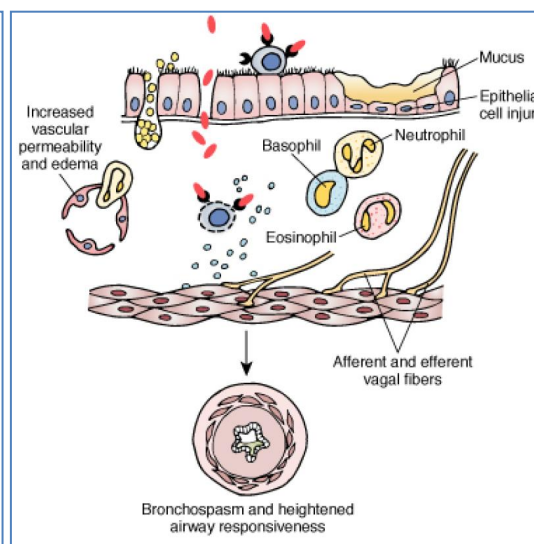
Asthma



Allergic Dermatitis



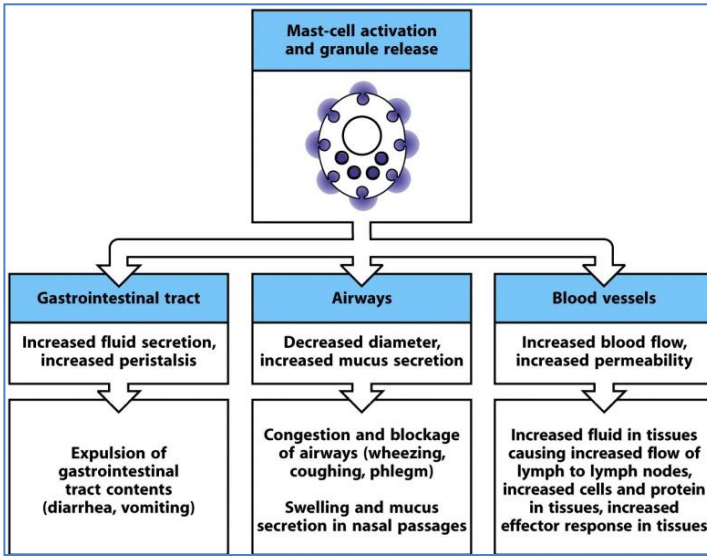
Early Phase Asthma



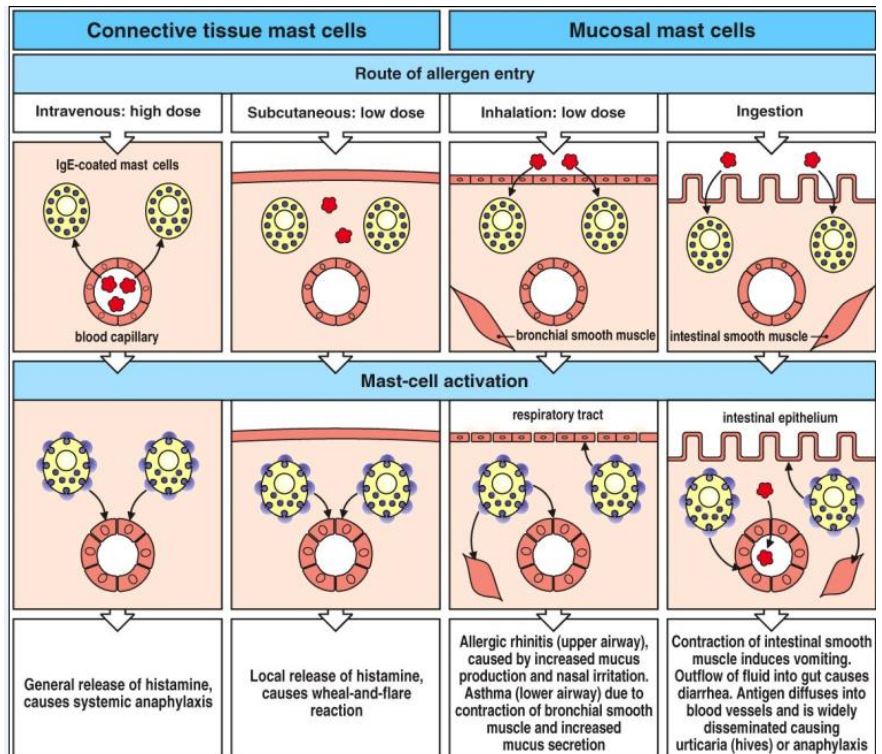
Late Phase Asthma

Clinical Effects of Mast Cell Degranulation:

- **Effects Depend On:**
 - 1. Specific Allergen
 - 2. Dose of Allergen
 - 3. Route of Entry (Antigen Location)



IgE-mediated allergic reactions			
Syndrome	Common allergens	Route of entry	Response
Systemic anaphylaxis	Drugs Serum Venoms Food, e.g. peanuts	Intravenous (either directly or following oral absorption into the blood)	Edema Increased vascular permeability Laryngeal edema Circulatory collapse Death
Acute urticaria (wheal-and-flare)	Animal hair Insect bites Allergy testing	Through skin Systemic	Local increase in blood flow and vascular permeability
Seasonal rhinoconjunctivitis (hay fever)	Pollens (ragweed, trees, grasses) Dust-mite feces	Inhalation	Edema of nasal mucosa Sneezing
Asthma	Danders (cat) Pollens Dust-mite feces	Inhalation	Bronchial constriction Increased mucus production Airway inflammation
Food allergy	Tree nuts Shellfish Peanuts Milk Eggs Fish Soy Wheat	Oral	Vomiting Diarrhea Pruritis (itching) Urticaria (hives) Anaphylaxis (rarely)



Blood Stream
Systemic anaphylaxis - anaphylactic shock

Airborne
Contact - allergic conjunctivitis
Inhalation - allergic rhinitis, allergic asthma

Skin
Localised - wheal and flare reaction
Generalised - urticaria
Chronic - atopic dermatitis (eczema)

Food
GIT transepithelial fluid loss

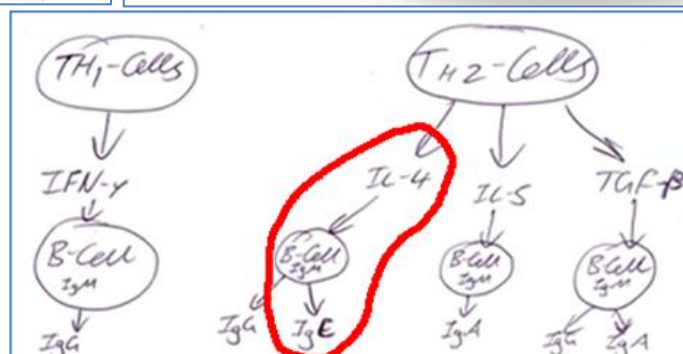
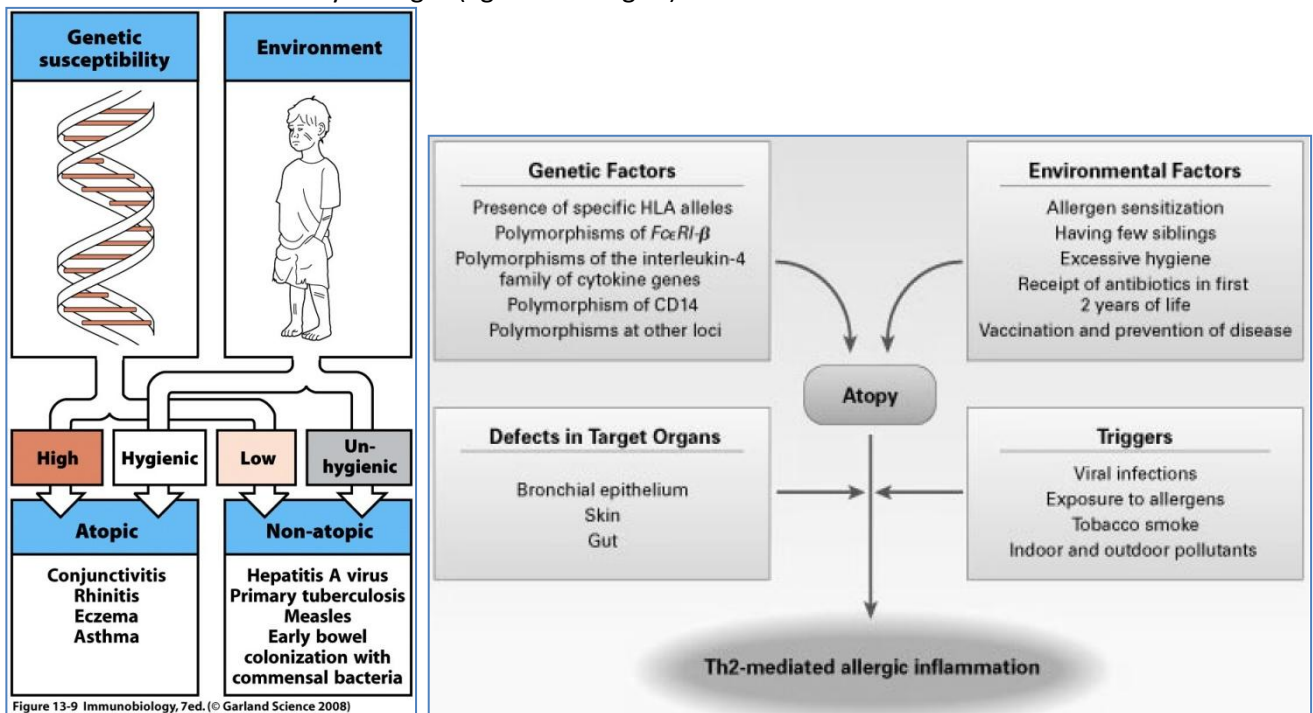
- **Determinants of Allergic Diseases (incl. Asthma):**

o **Genetic Susceptibility:**

- 'Atopy' has a strong familial basis.
- Ethnic differences in susceptibility for Atopy.
- There are distinct *Susceptibility Genes* for Allergic Diseases.

o **Environmental:**

- **'The Hygiene Hypothesis'** – A decrease in exposure to microbes in early childhood is a possible cause of the increase in allergies in high SES populations & Developed Countries.
 - Proposes that *Less Hygienic* Environments & Minor Infections during early childhood are protective against Atopy & Asthma.
 - Implies that Th2 (atopic) responses in early childhood are *Reprogrammed* to Th1 (non-atopic) responses by cytokines from early infections.
 - (Remember that Ig-Switching from IgM to IgE is Mediated by IL-4 from Th2-Cells.)
- Allergen Levels
- Environmental Pollution
- Dietary Changes (Eg. food allergies)



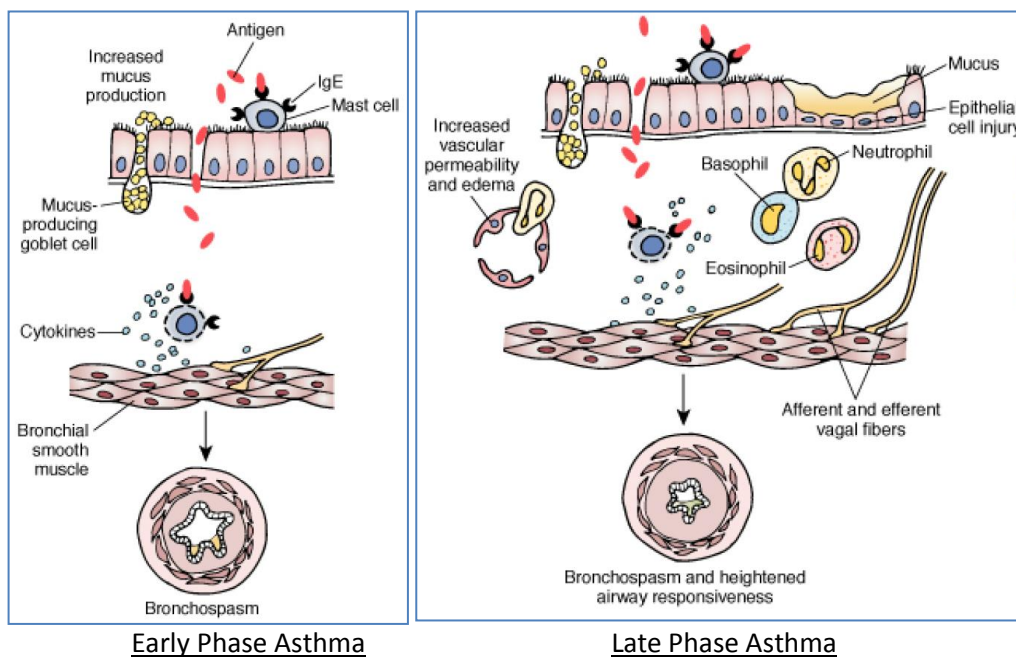
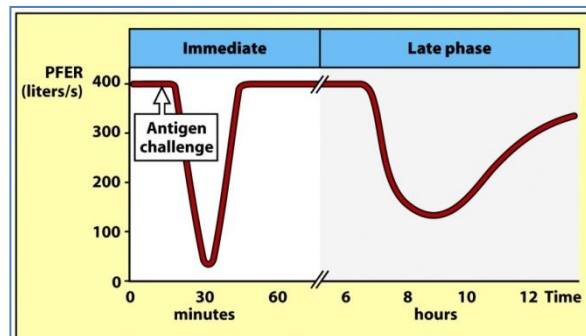
- **GLS Question – What is the Immunological Basis for Hypo-Sensitisation?:**

- o (AKA: Allergen Immunotherapy)
- o = Involves giving *Gradually-Increasing* quantities of specific allergens to people with IgE-Mediated (Type-I Hypersensitivity) Conditions. The *Aim* is to divert the Th2-Cell (IgE) Response to a Th1-Cell Response → Decrease in IgE Production.

EXAMPLES OF COMMON TYPE-I HYPERSENSITIVITY DISEASES:

**Eg. Allergic (Atopic) Asthma:

- **Exposure of Respiratory Sub-Mucosa to Allergen → Local Mast Cell Degranulation:**
 - → Local Histamine, Prostaglandin & Leukotriene Release
 - → Airway Vasodilation, ↑ Vascular Permeability & **Constriction of Airway Smooth Muscle (Bronchoconstriction)**
 - → Life-Threatening *Airway Obstruction*.
- **Triggers:**
 - Exposure to Allergens
 - Viral Infections
 - Tobacco Smoke
 - Pollutants
 - Exercise
 - Cold Air
 - Drugs – (β-Blockers, Aspirin, NSAIDs)
- **Biphasic Response:**
 - **Immediate Phase Response – The “Attack”:**
 - Occurs within seconds of Exposure.
 - Due to *Release of Preformed Mediators* by Mast-Cells:
 - (I.e. Histamine, Prostaglandins)
 - **Late Phase Response:**
 - Occurs 8-12hrs after Exposure → Oedema, SM Contraction, SM Hyperplasia, SM Hypertrophy.
 - Due to *Synthesis of Mediators* by Mast-Cells:
 - (I.e. Cytokines, Leukotrienes & Chemokines)



- **Pathophysiological Features:**
 - Airflow limitations → Wheezing & Hyperinflated Chest.
 - Over-distended lungs.
 - Airway hyper-reactivity – (Exaggerated broncho-constriction to non-specific stimuli)
 - Remodelling of Airway due to Inflammation:
 - ↑ Inflammatory Cells
 - Oedema
 - SM Hypertrophy
 - ↑ Mucous
 - (Often associated with Eczema, Urticaria/hives, Rhinitis, or Nasal Polyps)
- **Diagnosis:**
 - *Obstructive Spirometry – (Responsive to Bronchodilators)
 - IgE Levels – (Measurement of Allergic Status)
- **Treatment:**
 - **Symptomatic** – Bronchodilators (β -Agonists. Eg. Salbutamol)
 - **Immunosuppressants** – Inhaled Cortico-Steroids (ICS)
- **(NB: Other Types of Asthma):**
 - **Episodic Asthma:**
 - Pt is often asymptomatic but suffers attacks of asthma during URTI or after exposure to certain aeroallergens.
 - Common in older patients.
 - **Occupational Asthma:**
 - Variable airway obstruction caused by workplace exposures - (Fumes/Gases/Chemicals/Dust)
 - Due to hypersensitivity reaction to a substance at work.
 - Eg. Heavy exposure to Gas/Fumes/Vapour.

Eg. Allergic Bronchopulmonary Aspergillosis (ABPA):

- **What is it?**
 - An Allergic (Type-I Hypersensitivity) Reaction to Aspergillus Fungus.
- **Mechanism – Same as Asthma:**
 - **Exposure of Respiratory Sub-Mucosa to Aspergillus → Anti-Aspergillus IgE Antibodies → Bind to Mast Cells.**
 - **Re-Exposure → Local Mast Cell Degranulation:**
 - → Local Histamine, Prostaglandin & Leukotriene Release
 - → Airway Vasodilation, ↑ Vascular Permeability & Bronchoconstriction.
 - → Intense Bronchial Inflammation with high IgE & Eosinophilia.
- **Diagnostic Features:**
 - Asthma (majority of cases)
 - Mucus Plugging
 - Proximal Bronchiectasis
 - Positive Skin-test to an extract of Aspergillus Fungus.
 - Elevated serum IgE – (Specific to Aspergillus)
 - Shadows on Chest XR.
 - Presence of Aspergillus in Sputum Microscopy.
- **Treatment:**
 - Prednisolone (Oral Corticosteroid) → Immunosuppressant avoids further tissue damage.
 - High dose *Inhaled* Corticosteroid. → (As above)

Eg. Allergic Rhinitis:


- **What is it?**
 - Characterised by Episodes of Sneezing/Itching/Rhinorrhea/Nasal Obstructions.
- **Treatment:**
 - Allergen Avoidance
 - Anti-Allergic Meds
 - Immunotherapy for specific allergens.

****Eg. Anaphylaxis (& Anaphylactic Shock):**

- **Blood-Borne Antigen → Systemic Mast-Cell Degranulation:**
 - →Systemic Histamine, Prostaglandin & Leukotriene Release
 - →Systemic Vasodilation & ↑Vascular Permeability
 - →Life-Threatening *Fluid Shifts, Oedema & Hypotension* → **Anaphyl.Shock:**
- **Features of Shock – (The result of Hypoperfusion of Vital Organs):**
 - Low Blood Pressure
 - Cool Extremities
 - ↓Cerebral Perfusion → Altered Mental Status
 - ↓Renal Perfusion → ↓Urine Output
 - ↓Coronary Perfusion → Ischaemic Chest Pain
 - ↓General Tissue Perfusion → Lactic-Acidosis
- **Treatment:**
 - *Adrenaline – (A Vasoconstrictor, Antihistamine, Bronchodilator & Cardiostimulator)
 - Remove Causative Agent
 - Volume Replacement
- **GLS Q: How does Penicillin Cause Anaphylaxis?**
 - - **Penicillin forms Conjugates with Self-Proteins → Essentially *Modifying* them:**
 - →APCs can take up Penicillin-Modified Self-Peptides → Present them to Th2-Cells:
 - →Th2-Cells Activate Penicillin-Binding B-Cells → IgE against Penicillin.
 - →IgE binds to High Affinity Fc-Receptors on Mast-Cells
 - – **Binding of Penicillin to IgE-Bound Mast-Cells → Degranulation → Anaphylaxis:**
 - →Systemic Histamine, Prostaglandin & Leukotriene Release
 - →Systemic Vasodilation & ↑Vascular Permeability
 - →→Causes Life-Threatening *Fluid Shifts, Oedema & ↓BP* →Shock.

Type-II Hypersensitivity:

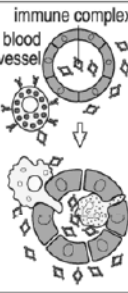
- **(Autoimmune Diseases & Drug Allergies) - DELAYED**
- **– Antibody-Mediated Attack against Altered Cell-Surface Antigens:**
 - **Eg. Drug-Induced Haemolytic Anaemia** (Drugs bind to surface antigens of RBCs)
 - **Eg. Autoimmune Thrombocytopaenia** (Drugs bind to surface antigens of Platelets)
 - **Eg. Rheumatic Heart Disease.** (Anti-*M-Protein*-Abs cross react with Cardiac Myosin)
- **Mechanism:**
 - **IgG Antibodies against specific Host Cell-Antigens bind to Cells & Opsonise them for Phagocytosis:**
 - → Altered Blood-Borne cells targeted are cleared by Macrophages in the Spleen.
 - (Eg. Drug-Induced Haemolytic Anaemia)
 - (Eg. Autoimmune Thrombocytopaenia)
 - → Tissue-Cells targeted are destroyed by *Resident* Macrophages in that tissue.
 - (Eg. Rheumatic Heart Disease)
 - **NB: Drug-Induced Haemolytic Anaemia/Thrombocytopaenia:**
 - Specific Drugs bind to the Surface of RBCs/Platelets → Are Targeted by Anti-Drug IgG.
 - → Anti-Drug IgG binding to RBCs/Platelets → Opsonises them for Phagocytosis in Spleen.

	Type II
Immune reactant	IgG
Antigen	Cell- or matrix-associated antigen
Effector mechanism	FcR ⁺ cells (phagocytes, NK cells)
	 <p>The diagram illustrates the mechanism of Type II hypersensitivity. It shows several platelets at the top, with Y-shaped antibodies binding to their surface. An arrow points down to a larger cell, likely a macrophage, which is engulfing one of the antibody-coated platelets, representing phagocytosis.</p>
Example of hypersensitivity reaction	Some drug allergies (e.g., penicillin)

Some common autoimmune diseases classified by immunopathogenic mechanism		
Syndrome	Autoantigen	Consequence
Type II antibody against cell-surface or matrix antigens		
Autoimmune hemolytic anemia	Rh blood group antigens, I antigen	Destruction of red blood cells by complement and FcR ⁺ phagocytes, anemia
Autoimmune thrombocytopenic purpura	Platelet integrin GpIIb/IIIa	Abnormal bleeding
Acute rheumatic fever	Streptococcal cell-wall antigens. Antibodies cross-react with cardiac muscle	Arthritis, myocarditis, late scarring of heart valves

Type-III Hypersensitivity:

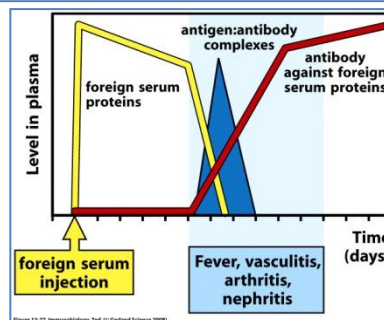
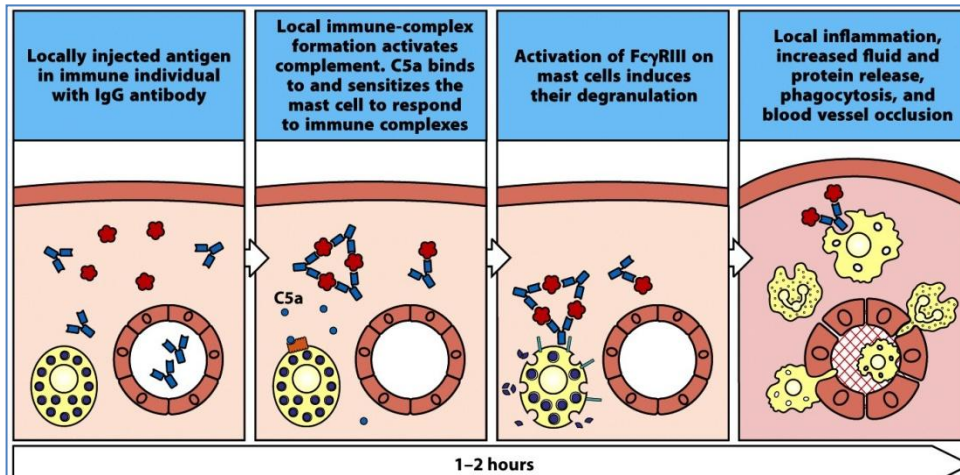
- (**'Arthus Reaction', 'Serum Sickness' & Some Autoimmune Diseases**) - **DELAYED**
- **Immune-Complex (Ag:Ab) Deposition → Activate Fc-Receptor⁺ & Complement :**
 - Eg. 'Arthus Reaction' → Vasculitis.
 - Eg. 'Serum Sickness'
 - Eg. Rheumatoid Arthritis
- **Mechanism:**
 - **Deposition of Small Immune-Complexes (Ag:IgG) in Vessel Walls:**
 - → IgG binds to Fc-Receptor on **Mast Cells** → Degranulation.
 - → Local Inflammation → Vasodilation, ↑Vascular Permeability.
 - → Local Oedema → Vessel Occlusion.
 - → Activation of **Complement** & Recruitment of Granulocytes.
 - →→**Vasculitis.**

	Type III
Immune reactant	IgG
Antigen	Soluble antigen
Effector mechanism	FcR ⁺ cells Complement immune complex blood vessel 
Example of hypersensitivity reaction	Serum sickness, Arthus reaction

Some common autoimmune diseases classified by immunopathogenic mechanism		
Syndrome	Autoantigen	Consequence
Type III immune-complex disease		
Mixed essential cryoglobulinemia	Rheumatoid factor IgG complexes (with or without hepatitis C antigens)	Systemic vasculitis
Rheumatoid arthritis	Rheumatoid factor IgG complexes	Arthritis

- **Eg. 'Arthus Reaction' → Vasculitis:**
 - Intradermal Injection of Antigen → In Situ formation of Ag:IgG Complexes:
 - Local Deposition of Ag:IgG in dermal Blood Vessels → Manifests as local Vasculitis.
- **Eg. 'Serum Sickness' → Vasculitis/Glomerulonephritis/Arthritis.**
 - IV Injection of Foreign Antigen (Eg. Tetanus Antiserum) → formation of Ag:IgG Complexes:
 - Systemic Deposition of Ag:IgG in Blood Vessels:
 - → Manifests as Vasculitis/GlomeruloNephritis/Arthritis. (Self-Limiting)

(NB: Rarely seen anymore due to advent of *Monoclonal Antibodies*.)



Arthus Reaction → Vasculitis

Serum Sickness

○ **Other Examples of Immune-Complex (Type-III Hypersensitivity) Diseases:**

Bacterial diseases

Streptococcal infections, Mycoplasma pneumonia, leprosy, syphilis

Viral diseases

Infectious mononucleosis, hepatitis, Dengue

Parasitic diseases

Malaria, Leishmaniasis

Autoimmune diseases

Rheumatoid arthritis, systemic lupus erythematosus, autoimmune thyroiditis

Others

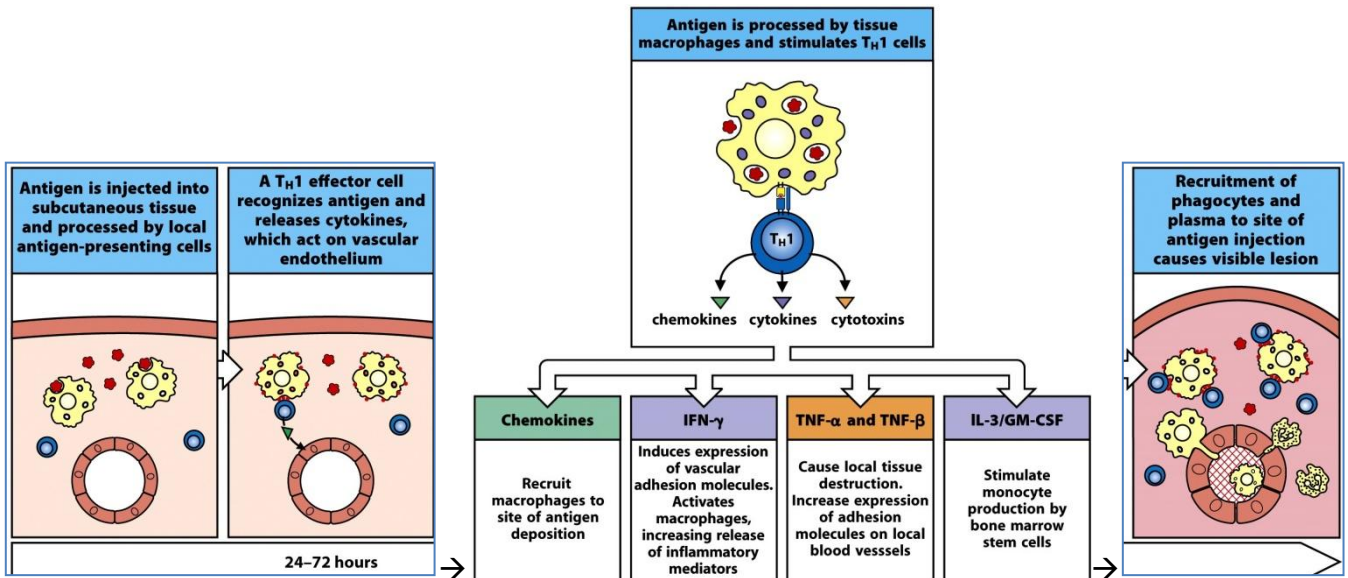
Serum sickness, hypersensitivity pneumonitis, IgA nephropathy

Type-IV Hypersensitivity:

- **(Autoimmune Diseases) - DELAYED**
- **Function of Th1, Th2 & Cytotoxic T-Cells:**
 - o ***Th1 – Eg. Contact Dermatitis, Tuberculin Reaction (Mantoux Test) – OUR FOCUS!**
 - o Th2 – Eg. Chronic Asthma, Chronic Rhinitis.
 - o CTL – Eg. Type-1-Diabetes Mellitus
 - o Eg. Multiple Sclerosis
 - o Eg. Coeliac Disease

Mechanism:

- o **Pre-Primed Ag-Specific Th-1-Cells Recognise and Bind Macrophages displaying Ag:MHC-II**
→ Activates Macrophages → Secretion of Cytokines, Chemokines & Cytotoxins:
 - IFN γ & TNF β → Activates Endothelium & \uparrow Vessel Permeability → inflammation.
 - → Visible Swelling
 - → Tissue Damage → **Granulomas**



	Type IV		
Immune reactant	Th1 cells	Th2 cells	CTL
Antigen	Soluble antigen	Soluble antigen	Cell-associated antigen
Effector mechanism	Macrophage activation	IgE production, Eosinophil activation, Mastocytosis	Cytotoxicity
	<p>IFN-γ → Th1</p> <p>chemokines, cytokines, cytotoxins</p>	<p>IL-4, IL-5 → Th2</p> <p>eotaxin</p> <p>cytotoxins, inflammatory mediators</p>	<p>CTL</p>
Example of hypersensitivity reaction	Contact dermatitis, tuberculin reaction	Chronic asthma, chronic allergic rhinitis	Contact dermatitis

Some common autoimmune diseases classified by immunopathogenic mechanism		
Syndrome	Autoantigen	Consequence
Type IV T-cell-mediated disease		
Type 1 diabetes	Pancreatic β -cell antigen	β -cell destruction
Rheumatoid arthritis	Unknown synovial joint antigen	Joint inflammation and destruction
Multiple sclerosis	Myelin basic protein, proteolipid protein, myelin oligodendrocyte glycoprotein	Brain invasion by CD4 T cells, muscle weakness, and other neurological symptoms

IMMUNOLOGY Pathology:
IMMUNODEFICIENCY

2. Immuno-Deficiency – (Host Defences are Abnormal):

- **Primary Immune Deficiency:**
 - (I.e. Host defences are *Inherently/Genetically* Defective)
 - Most have Genetic Aetiology.
- **Secondary Immune Deficiency:**
 - (I.e. Physically/Chemically/Infectively –Induced Immune Deficiency)
 - **Physically-Induced Immune Deficiency:**
 - Eg. Radiation
 - **Chemically-Induced Immune Deficiency:**
 - Eg. Drugs – Corticosteroids/Immunosuppressants.
 - **Infectively-Induced Immune Deficiency:**
 - Eg. HIV

“Red-Flags” for Immunodeficiency:

- **History:**
 - **1. History of Unusual Number of Infections:**
 -
 - **2. History of Severe/Unusual TYPES of Infections:**
 - Eg. Overwhelming Infections *without* a predisposing cause.
 - Eg. Recurrent Infections with *Low Virulence Organisms* – (I.e. Commensals/yeasts/Staph Epi)
 - Eg. Infections with *Unusual Organisms* – (Eg. PCP, Serratia)
 - Eg. Infections in *Unusual Sites* – (Eg. Nails)
 - **3. History of a Predisposing Event Compromising the Immune System:**
 - Malnutrition
 - Nutrient Deficiencies – (Eg. ↓Vit. A)
 - Specific Viral Infections – (Eg. HIV, Measles)
 - Immunosuppressive Therapy – (Eg. Asthma Corticosteroids)
 - Cancer Chemotherapy/Radiotherapy.
 - Adverse Drug Reactions
 - Autoimmune Disorders
 - Splenectomy/Thyroidectomy/Tonsilectomy
- **Examination:**
 - **Syndromes Associated with Immunodeficiency:**
 - Eg. Down’s Syndrome
 - Eg. Ataxia Telangiectasia
 - Eg. Kwashiorkor – (→Severe Malnutrition)
 - Eg. DiGeorge Syndrome
 - **Skin Manifestations:**

Skin findings	Syndrome/defect
Eczema and petechiae	Wiskott-Aldrich
Telangiectasia	Ataxia-telangiectasia
Oculocutaneous albinism	Chédiak-Higashi
Chronic dermatitis	Hyper-IgE syndrome
Extensive molluscum, warts, candidiasis	T-cell deficiency
 - **Sites & Nature of Infection:**
 - Eg. Fungal Infection of Nail Beds.
 - Eg. Multiple Abscesses
 - **Absence of Tonsils**
 - **Lymph Nodes:**
 - Eg. Obvious infection, but no Lymph Node Swelling.
 - **Nutritional State.**

- **Gingivostomatitis:**
 - Inflammation of the Oral Mucosa and Gingiva.

Laboratory Investigations – Confirming your Suspicion:

- **Blood Count:**
 - Full Blood Count
 - Specific Count of Cell Types:
- **White Cell Morphology:**
 - **B-Cells:**
 - Number
 - Phenotyping
 - **T-Cells:**
 - Number
 - Phenotyping
 - Cytokine Production
 - Response to Mitogens – (Ie. Lymphocyte Proliferation Assays)
 - **NK-Cells – Cytotoxicity**
 - **Phagocytic Function:**
 - Adhesion
 - Killing
- **Immunoglobulin Count:**
 - **Specific Ig-Isotype Titres:**
 - (IgG, IgA, IgM)
 - **Antibody Response to Disease:**
 - Immunisation response.
- **Complement Count:**
 - Eg. In Glomerulonephritis/Nephrotic Syndrome – Complement proteins can be lost in urine.
- **Skin Tests**
 - For Delayed Hypersensitivity (Eg. **Type-IV** For TB)
- **Molecular Genetics:**
 - Looking for genetic mutations associated with known Immuno-Deficiencies.

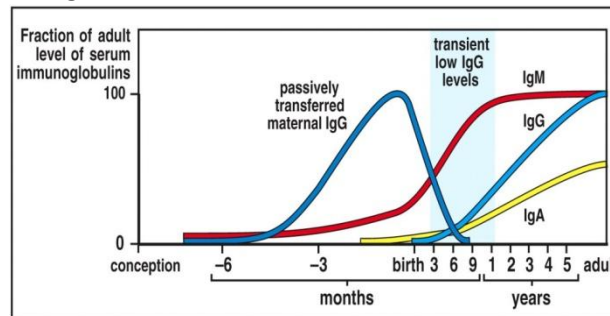
Clinical Categories for Understanding Immunodeficiency:

- PID – Primary Immunodeficiency:

○ Primary B-Cell Diseases:

▪ ↓Antibodies → Inability to Clear *Extracellular* Organisms → Recurrent Infections:

- Eg. IgG Deficiency
- Eg. IgA Deficiency
- Eg. **Bruton's X-linked Agammaglobulinaemia – (X-Linked Recessive)**
- Eg. **Common Variable Immune Deficiency – (Abs are present, but non-functional)**
- Eg. **Transient Hypogammaglobulinaemia of Infancy. (THI)** – Around 6-12mths; between when Maternal IgG wanes and when infants begin to make their own IgG.



○ Primary T-Cell Diseases:

- **Presents as Severe Infections in Infancy**
 - (Or Chronic Thrush (Mucocutaneous Candidiasis))
- **Often Presents as Recurrent Viral/Fungal Infections**
- **Often Associated with B-Cell Defects:**
 - Eg. Thymic Hypoplasia – (I.e. DiGeorge Syndrome)
 - Eg. **Hyper IgM Syndrome – (T-Cells fail to direct B-Cells in Isotype Switching)**
 - Eg. Defective Cytokine Receptors
 - Eg. Defective Cytokine Production

○ Combined B- & T-Cell Diseases:

- **Presents as Severe, Frequent, Opportunistic Infections → Early Death.**
 - ***Eg. SCID – Severe Combined Immuno-Deficiency – (X-Linked Recessive)**

○ Disorders of Phagocytic Function:

- **Inability to contain Local Infections → Chronic Abscesses.**
- **2 Major Categories:**
 - Eg. **Leukocyte Adhesion Deficiency**
 - Eg. **Defects of Intracellular Killing – (I.e. 'Chronic Granulomatous Disease')**

○ Disorders of the Complement System:

- **Defective Humoral Immune Function → Chronic Infections:**
 - Eg. Classical Pathway Deficiency – (C2,3,5,6,7,8,)
 - Eg. Alternative Pathway Deficiency – (Properdin Deficiency)
 - Eg. C1-Esterase Deficiency → Angioedema

- **SID – Secondary Immunodeficiency:**

○ ***HIV:**

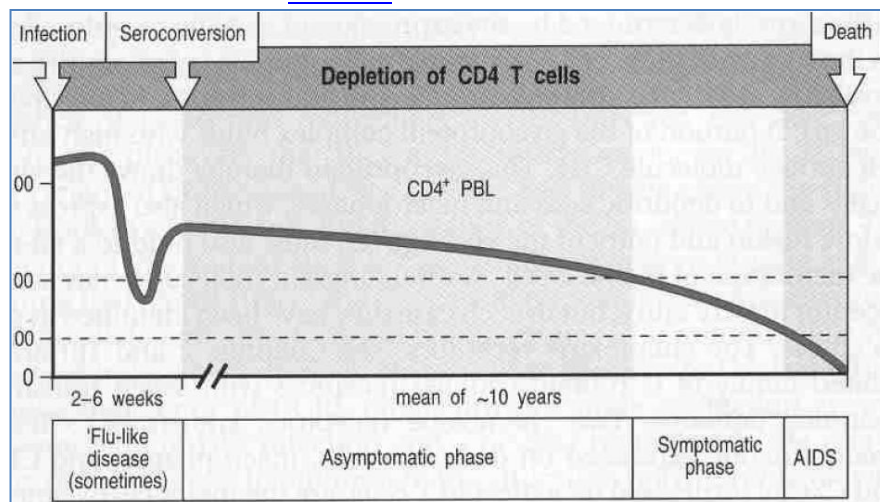
▪ **Why does it lead to Acquired Immunodeficiency?:**

- Directly – Via killing of infected cells.
 - *Killing of Infected CD4 Cells by CD8-Cytotoxic-T-Cells
 - (Low CD4 count → Loss of Cell-Mediated Immunity)
- Increased Susceptibility to Apoptosis of Infected Cells

▪ **6 Stages of HIV & AIDs:**

- 1. Acute Seroconversion Illness
- 2. Asymptomatic HIV Infection – (CD4 count >500)
- 3. Early Symptomatic HIV Infection – (CD4 count >500)
- 4. Middle Symptomatic HIV Infection – (CD4 count 200-400)
- 5. Late Symptomatic HIV Infection – (CD4 count <200)
- 6. Advanced HIV Disease.

▪ **To successfully** reproduce itself, HIV must convert its RNA **genome** to **DNA** via **Reverse Transcriptase**, which is then imported into the host cell's nucleus and inserted into the host genome through the action of **HIV integrase**. Because HIV's primary cellular target, CD4+ T-Cells, functions as the **memory cells** of the **immune system**, integrated HIV can remain **dormant** for the duration of this cell's lifetimes.



- (Others – Malnutrition, Immunosuppressive Therapy, Splenectomy, Etc)

Treating Immunodeficiency:

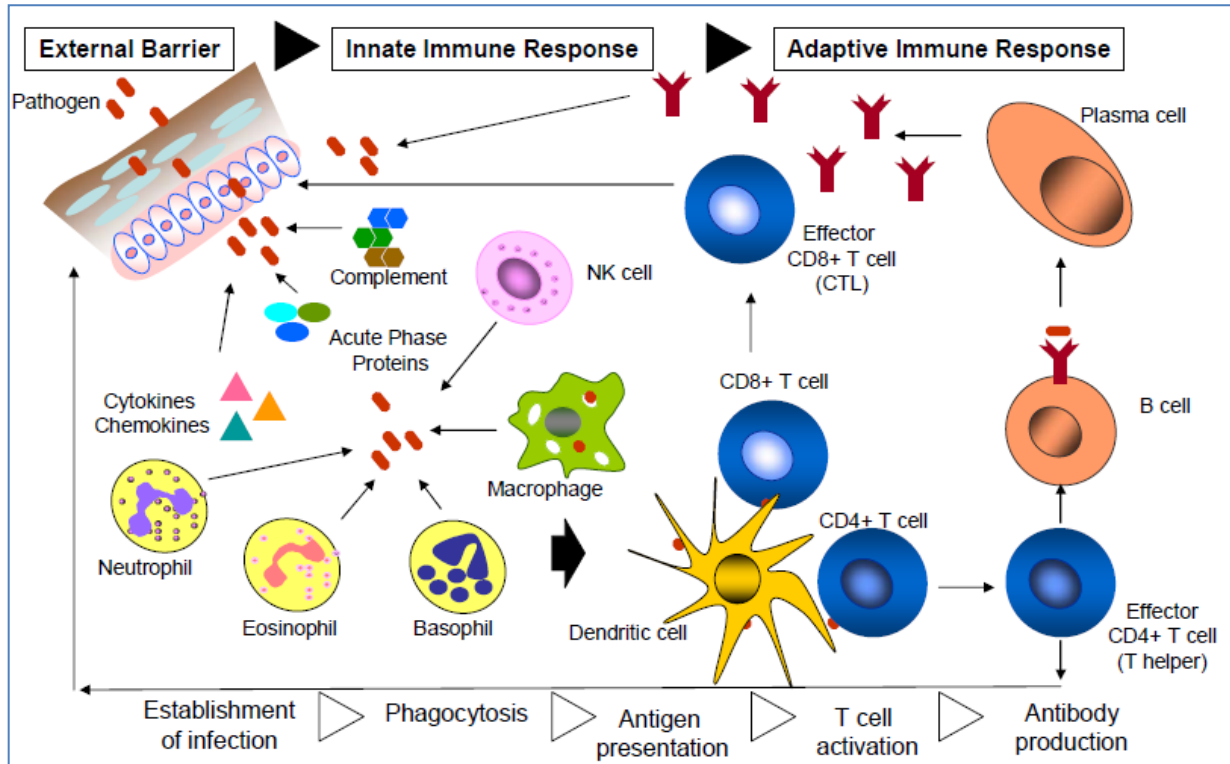
- **Treating B-Cell Defects:**
 - Antibiotics
 - IV Immunoglobulins
- **Treating T-Cell & Combined Immunodeficiencies:**
 - Quarantine
 - Antibiotics
 - Bone Marrow Transplant
 - Thymic Transplant (in DiGeorge Syndrome)
- **Treating Phagocytic Dysfunction:**
 - Antibiotics
 - Bone Marrow Transplant
- **Treating Complement Deficiency:**
 - Plasma Infusion
 - Treatment of Infections
- **Treating Secondary Immune Deficiencies:**
 - Prevention
 - Aggressive Treatment
 - Antiretroviral Agents (In HIV)

IMMUNOLOGY Pathology:
INFECTION IMMUNOLOGY

The Immune System - During Infection:

Innate Immune System: The passive & rapid-response mechanisms of the immune system that defend the host from infection by other organisms, in a non-specific manner. (I.e. Recognises & responds to pathogens in a generic way) Unlike the adaptive immune system, it doesn't confer long-lasting immunity (memory).

Adaptive Immune Responses: The highly-specialised mechanisms of the immune system that, once activated by the Innate Immune System, has the ability to recognise & remember specific pathogens and mount stronger attacks each time the pathogen is encountered.



Stages of Infection:

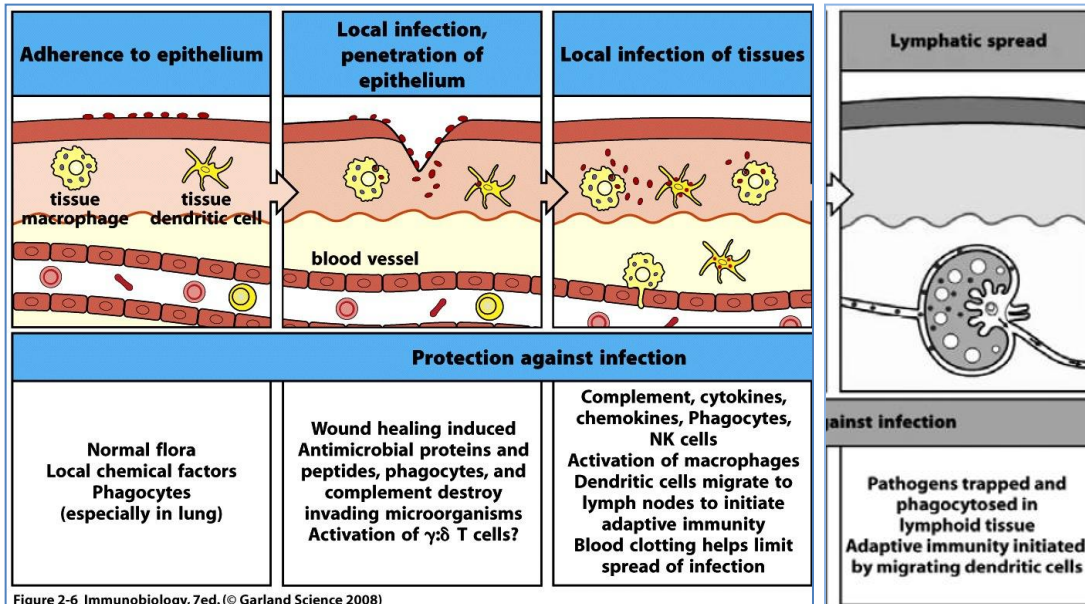
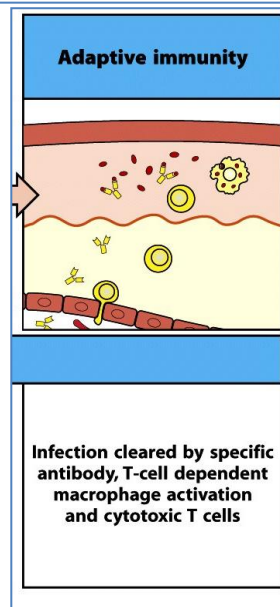
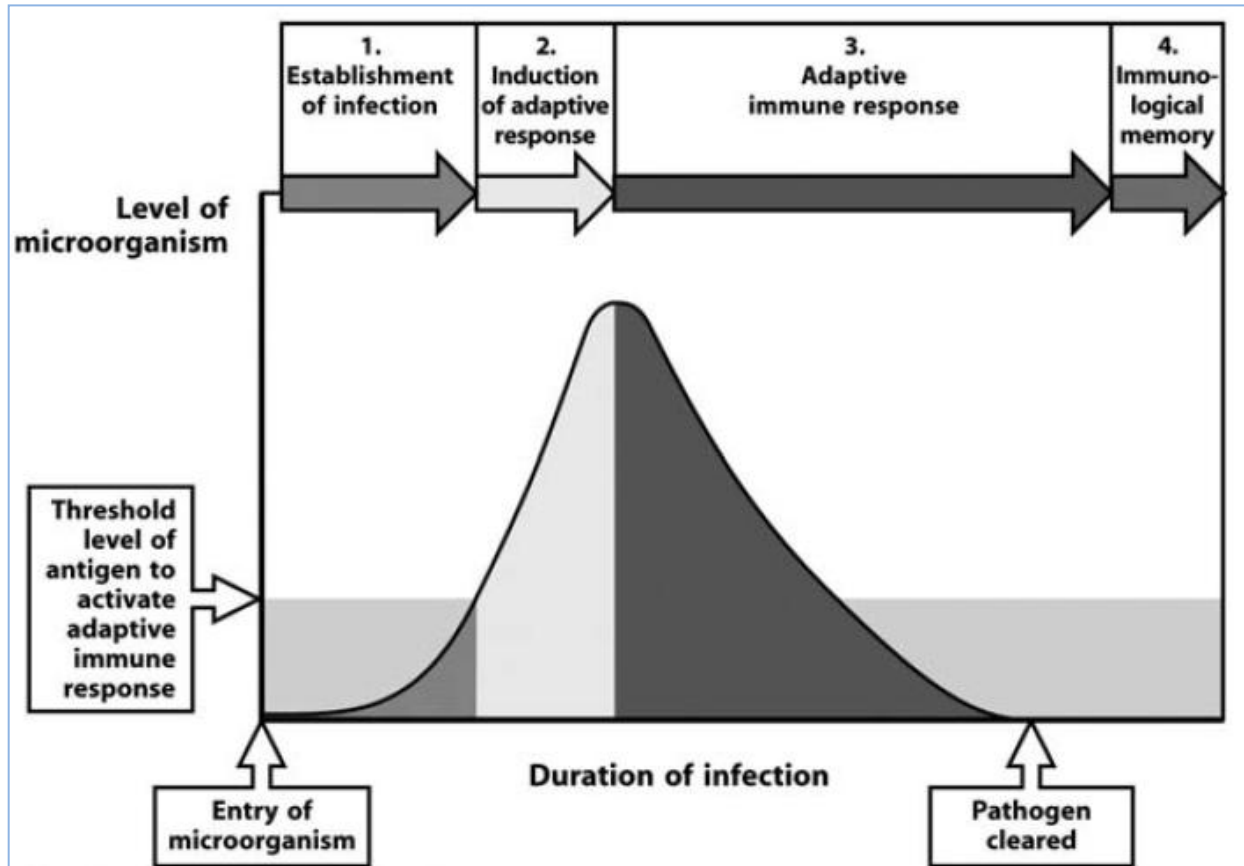


Figure 2-6 Immunobiology, 7ed. (© Garland Science 2008)



NB: If Antigen enters the blood, it is filtered by the spleen, not the lymph node.

The course of a Typical Acute Infection:



	INNATE IMMUNE RESPONSE		ADAPTIVE IMMUNE RESPONSE
	Immediate (<4 hours)	Early (4-96 hours)	Late (96> hours)
Barriers	Skin Mucosal cell surface	Local inflammation C3a, C5a, TNF- α	Local inflammation IgA in mucosal surfaces IgE bound to mast cells
Extracellular infection	Phagocytes Lectin & alternate complement pathways	C-reactive proteins Complements Thymus independent B cell antibodies	IgM and IgG antibodies Classical complement pathway activation Fc receptor expression on cells
Intracellular infection	Macrophages	NK cell activation Macrophage activation IL-1, IL-6, TNF- α , IL-12	T cell activation and secretion of IFN- γ Macrophage activation
Characteristics	Nonspecific No specific T, B cells	Nonspecific No specific T, B cells No memory	Specific Specific T, B cells Memory

Primary & Secondary Immune Responses:

- **Primary Response:** The Body's Initial Response to a Novel Antigen.
 - o **Lag Phase:** Approx. 6 Days = The period during which the Innate Immune Response is in Action & the Adaptive Immune System is being sensitized.
 - o **Antigen Response:** B-Cells of the adaptive immune system secrete Antibodies.
- **Secondary Response:** Very small Lag-Period, then an Amplified Antibody Response due to Pre-Existing Memory B-Cells, which rapidly proliferate & differentiate into specific Ab-Secreting Plasma Cells.
 - o NB: Antibody levels from Secondary Responses *Persist Longer*.

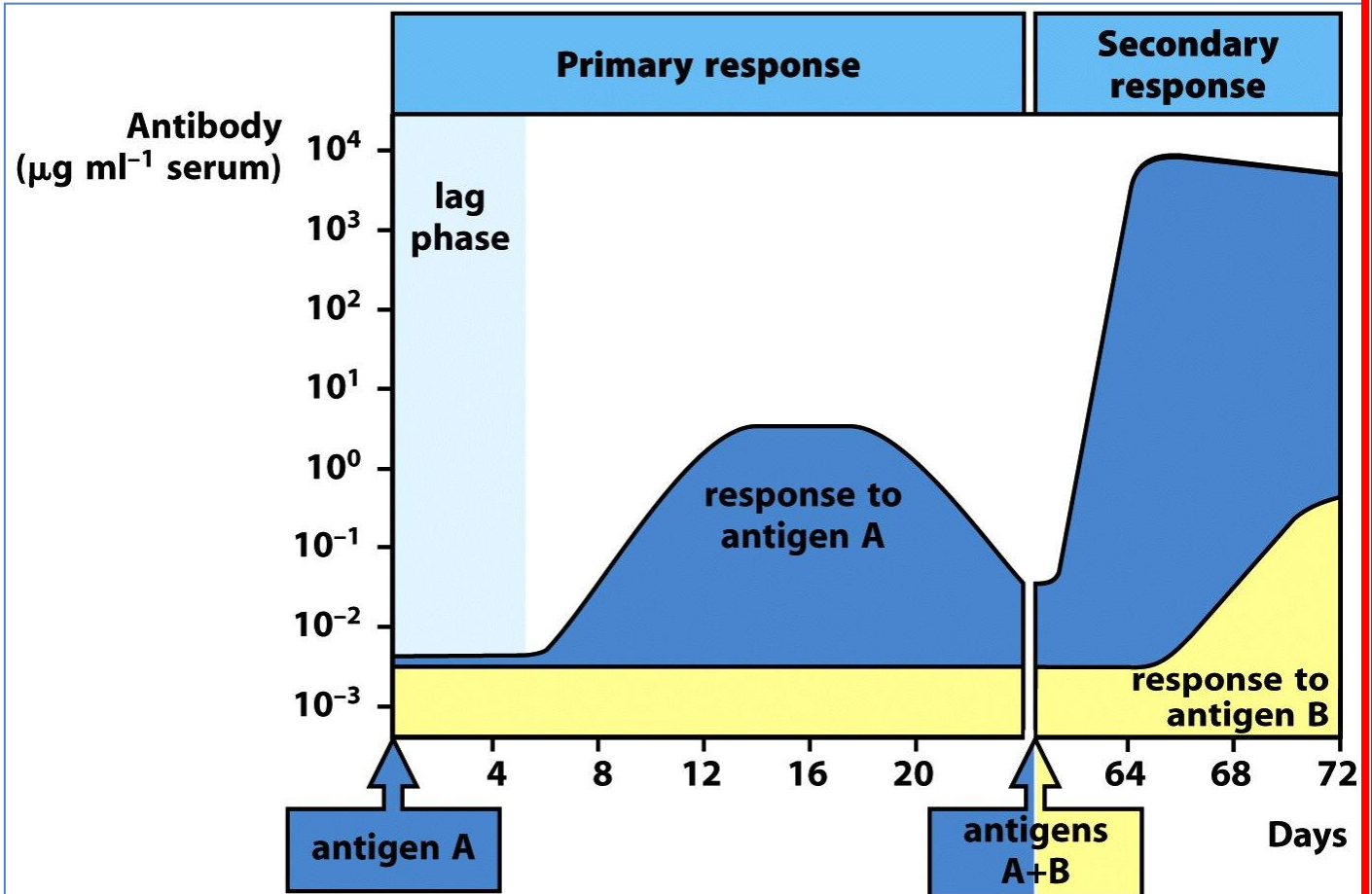


Figure 1-24 Immunobiology, 7ed. (© Garland Science 2008)

Cell Adhesion Molecules (CAM's) & Leukocyte Migration:

CAMs = Proteins displayed on Immune Cells and Vascular Endothelium, that aid in:

- 1) Routine Lymphocyte Circulation, and
- 2) Migration & 'Homing' of WBCs to Extravascular sites.

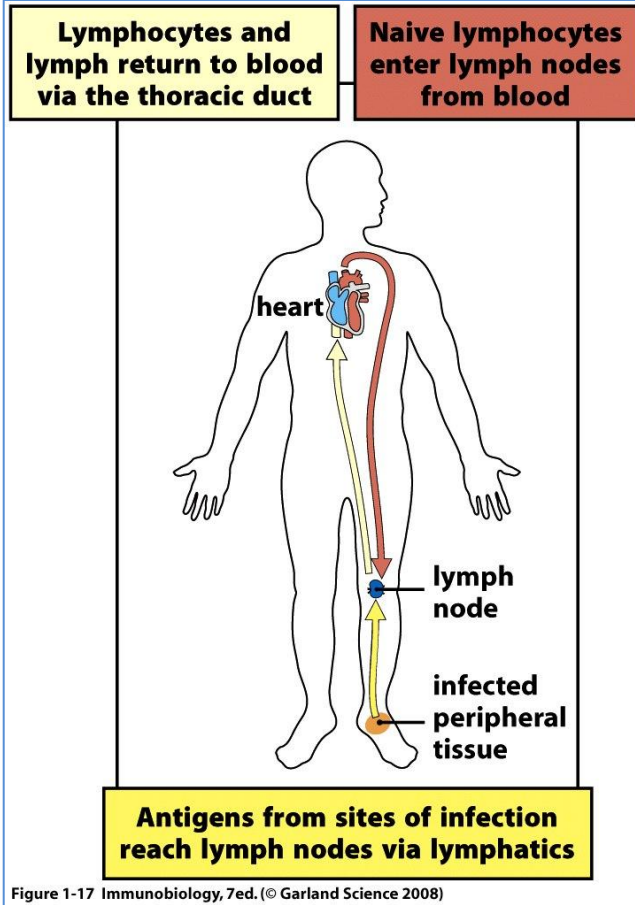
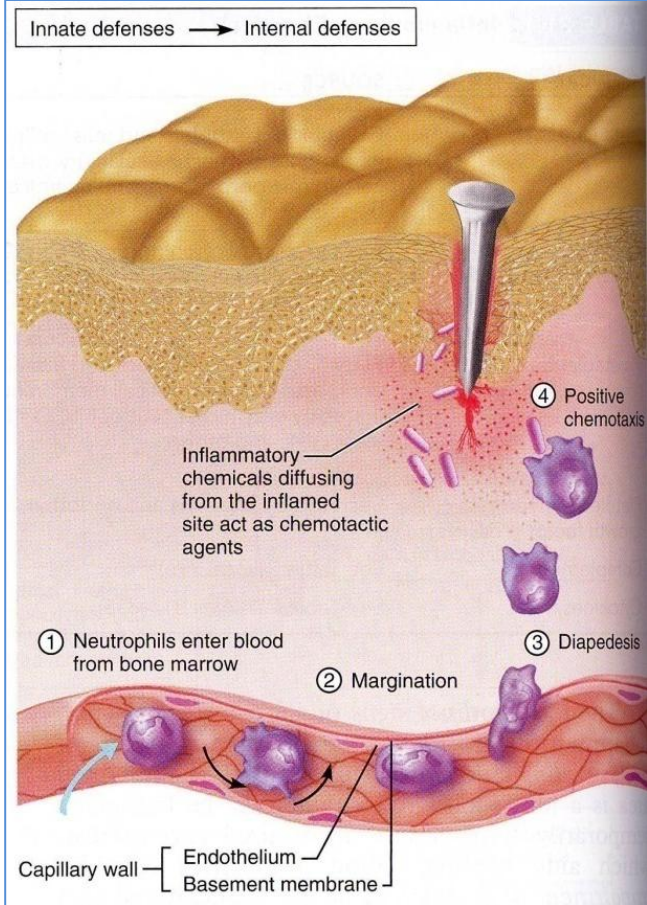


Figure 1-17 Immunobiology, 7ed. (© Garland Science 2008)

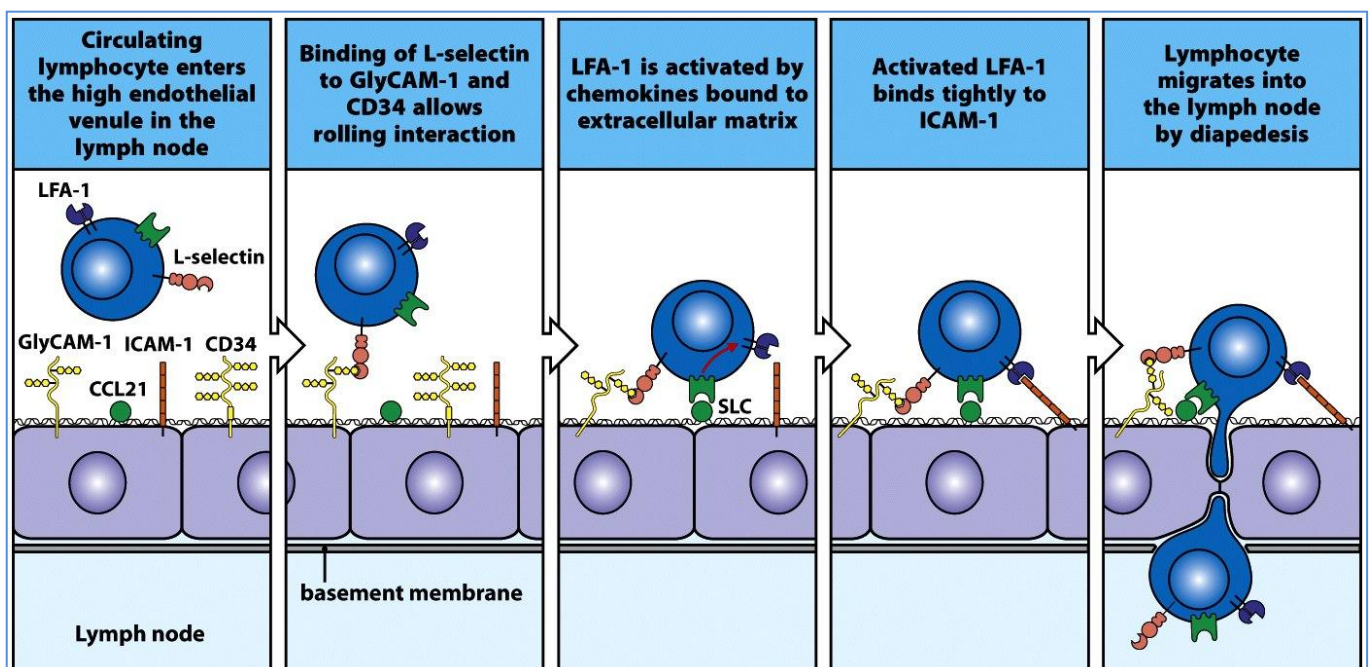


		Name	Tissue distribution	Ligand
Selectins	P-selectin	P-selectin (PADGEM, CD62P)	Activated endothelium and platelets	PSGL-1, sialyl-Lewis ^x
		E-selectin (ELAM-1, CD62E)	Activated endothelium	Sialyl-Lewis ^x
Integrins	LFA-1	$\alpha_1:\beta_2$ (LFA-1, CD11a:CD18)	Monocytes, T cells, macrophages, neutrophils, dendritic cells	ICAMs
		$\alpha_M:\beta_2$ (CR3, Mac-1, CD11b:CD18)	Neutrophils, monocytes, macrophages	ICAM-1, iC3b, fibrinogen
		$\alpha_X:\beta_1$ (CR4, p150.95, CD11c:CD18)	Dendritic cells, macrophages, neutrophils	iC3b
		$\alpha_5:\beta_1$ (VLA-5, CD49d:CD29)	Monocytes, macrophages	Fibronectin
Immunoglobulin superfamily	ICAM-1	ICAM-1 (CD54)	Activated endothelium	LFA-1, Mac1
		ICAM-2 (CD102)	Resting endothelium, dendritic cells	LFA-1
		VCAM-1 (CD106)	Activated endothelium	VLA-4
		PECAM (CD31)	Activated leukocytes, endothelial cell-cell junctions	CD31

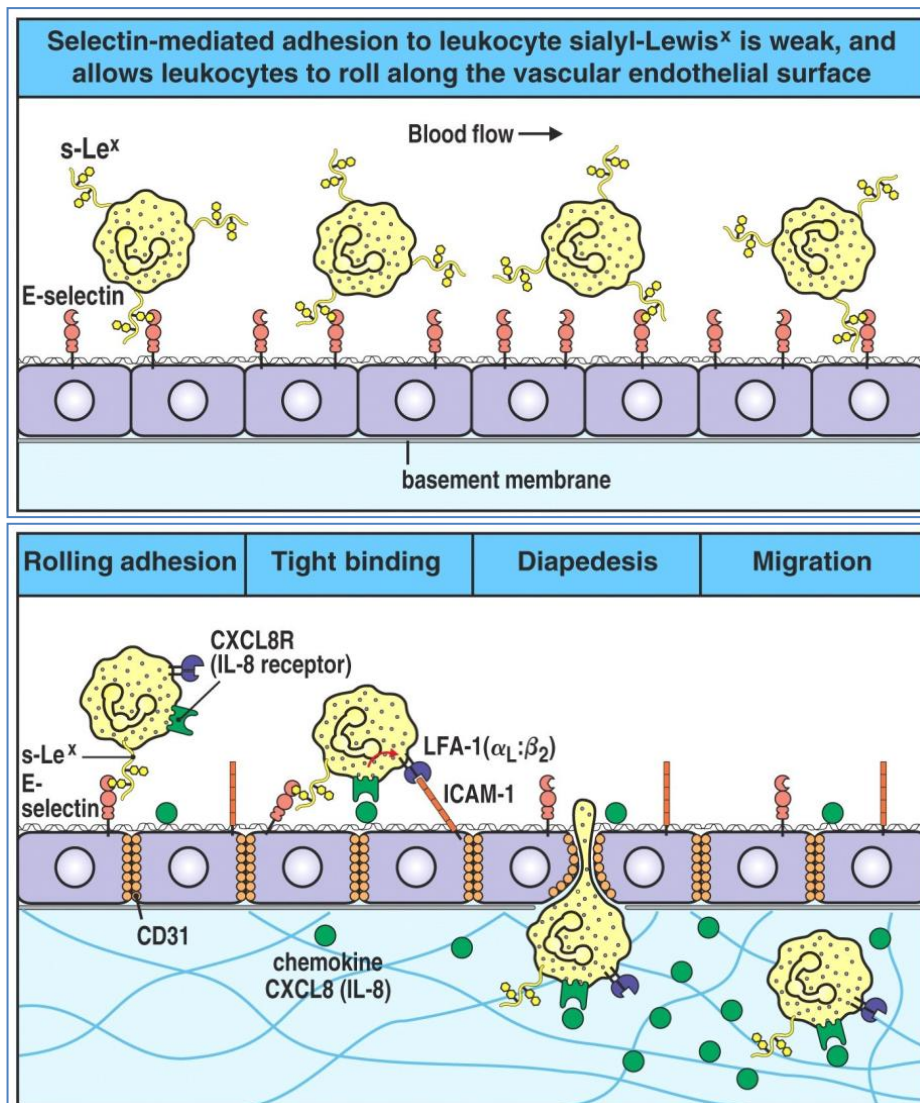
Figure 2-47 Immunobiology, 7ed. (© Garland Science 2008)

CAMS – The Basics: With the help of various cytokines, interactions between CAMs on Immune Cells & the Endothelium cause **Margination** (Adhesion) of Immune Cells to the Endothelium Wall. Following margination, **Diapedesis** occurs (Migration of immune cells through the endothelium wall). There are multiple types of CAMs, including Selectins, Integrins, Addressins, ICAM, GlyCAM & LFA-1. See below for more detail...

- **1) Routine Lymphocyte Circulation (Blood → Lymphatics):** Lymphocytes are constantly circulating between the Blood Vessels, the Lymphatic System & Lymphoid Tissues to ensure that they are readily available to attend to infected/damaged sites quickly. **How?:**
 - Naive T-Cells preferentially leave the blood & enter Lymph Nodes across High Endothelial Venules (HEVs – specialised post-capillary vessels found in T-Cell areas of all secondary lymphoid organs, except the spleen. They are the Naive T-Cell’s gateway into the lymphatic system – Particularly to Lymph Nodes)
 - The specialised endothelium lining these HEVs expresses a number of molecules involved in lymphocyte homing to the lymph node:
 - **GlyCAM-1**
 - **ICAM-1**
 - **Chemokines** (Membrane Bound)
 - The initial binding of the Naive T-Cell to the vascular endothelium (HEV) is mediated by **L-Selectin** binding to **GlyCAM-1**.
 - Next, the binding of **Chemokines** on the vascular Extracellular Matrix to the Naive T-Cell triggers TIGHT binding of **LFA-1** to **ICAM-1**, arresting the lymphocyte on the endothelium.
 - The Naive T-Cell is then able to migrate across the endothelium, and into the T-Cell area of the Lymph Node. There it can inspect Dendritic Cells in the lymph node for the presence of its specific Antigen.
 - If it doesn’t recognise any Antigens, the T-Cell is not activated & passes out of the lymph node to return to the circulation.
 - The Naive T-Cells that do meet their specific antigen, are then activated via Antigen Presentation to their Antigen Receptors (TCRs), and begin to proliferate & mature into Effector CD4 & CD8 T-Cells within the Lymph Node.
 - The activated CD4-T-Cells then activate antigen-specific B-Cells which migrate to nearby follicles & begin secreting Antibodies into the lymph → Blood.
 - The activated CD8-T-Cells leave the lymph node & return to the Blood ready to fight off invaders. They exit the lymphatic system through the Efferent Lymphatics → The Thoracic Duct → the Superior Vena Cava.
 - **NB:** Most of the Lymphocytes in Peripheral Blood are T-Cells, despite being only 2% of the total lymphocyte population.



- **2) Migration & Homing of WBCs (Blood → Peripheral Tissue): Effector+Memory T-Cells** (i.e. Activated T-Cells), as well as **Monocytes** and **Granulocytes**, are recruited from the blood and enter Peripheral Tissues through the vascular Endothelium of Venules at sites of Infection/Injury.
 - **Leukocytosis** – Injured cells release ‘**Leukocytosis-Inducing Factors**’ which promote rapid release of WBC’s from red bone-marrow → Leukocytosis (High WBC count).
 - **Margination** – Activated vascular endothelial cells express a number of Adhesion Molecules involved in arresting WBCs at the site of infection:
 - **E-Selectin**
 - **ICAM-1**
 - **Chemokines** (Membrane Bound) (In this case = **IL-8**)
 - Leukocytes (WBCs) initially adhere by binding to **E-Selectin** on the endothelium, which recognises the **Sialylated Lewis X Carbohydrate (S-Le^x)**, & other glycoprotein ligands on the leukocytes.
 - Next, as the leukocyte rolls over, **LFA-1** weakly binds to **ICAM-1**.
 - Subsequently, the binding of **Chemokine IL-8** on the vascular Extracellular Matrix to the Leukocyte triggers TIGHT binding of **LFA-1** to **ICAM-1**, arresting it on the endothelium.
 - **Diapedesis** – The tightly-bound leukocyte now migrates across the endothelium, squeezing between adjacent endothelial cells.
 - **Chemotaxis** – The Leukocyte then follows the Chemokine Concentration Gradient to the site of injury/infection. (Specifically, IL-8 – a Chemoattractant & Angiogenic Factor).
 - **NB:** Monocytes that migrate into inflamed tissue mature into macrophages



NB: Leukocyte Adhesion Deficiency: This disorder stems from a defect in the B₂ chain of the LFA-1 Molecule required for tight binding of the Leukocyte to the ICAM-1 receptor on the Endothelium. These patients are prone to recurrent infection & impaired wound healing due to diminished capacity to recruit inflammatory cells in response to infection or injury.

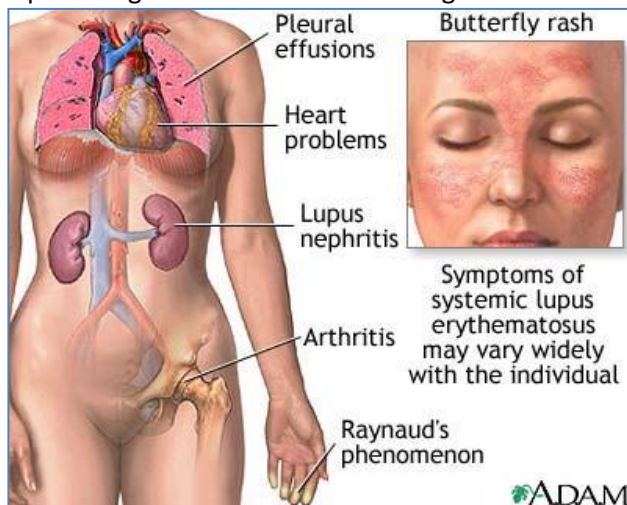
RHEUMATOLOGY Pathology:
LUPUS

Systemic Lupus Erythematosus (SLE):

- **What is it?**
 - **Chronic Multi-System Autoimmune Disease.**
 - ***Characterised by Many Different Anti-Nuclear Antibodies:**
 - * Anti-DNA
 - Anti-Ribonucleoprotein
 - Anti-Histone
 - (NB: Autoantibodies may attack directly or form Immune-Complexes → Disease)
 - **F:M (10:1)**

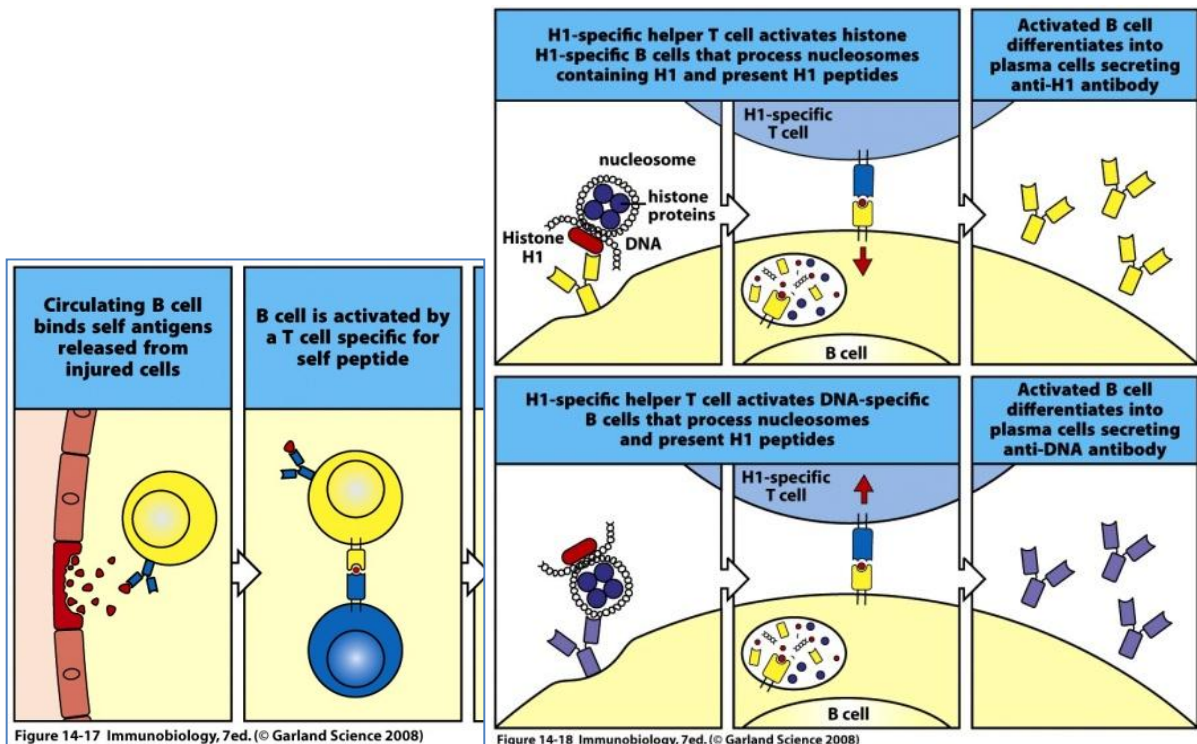
- **Manifestations:**
 - Skin Rash
 - Arthritis
 - Glomerulonephritis
 - Haemolytic Anaemia
 - Thrombocytopenia
 - CNS Involvement

- **Diagnostic Criteria:**
 - Malar Rash (Scaly, Red, Butterfly-Shaped rash on face)
 - Disc-like rash
 - Photosensitive Rash
 - Oral Ulcers (Or in Nasal Cavity)
 - Arthritis (Non-erosive)
 - Serositis – (Eg. Pleuritis or Pericarditis)
 - Renal Disorders – (Eg. Glomerulonephritis, Proteinuria, Cellular Casts)
 - Neurological Disorders – (Eg. Seizures/Psychosis)
 - Haematological Disorders – (Eg. Haemolytic Anaemia, Leukopenia, Thrombocytopenia)
 - Antinuclear Antibody Test – Positive.
 - **Serological Tests:**
 - **Antinuclear Antibody (ANA) Test** – (95% of SLE Pts are ANA positive):
 - The hallmark of systemic autoimmunity
 - However, not specific to SLE. (ENA test required for definitive diagnosis)
 - **Extractable Nuclear Antigens (ENA):**
 - Once presence of ANAs have been determined, ENAs are used to determine the specific Ag that the ANAs are binding to in the nucleus.



- **Pathogenesis:**

- ***SLE is Caused by Presence of Different Anti-Nuclear Antibodies – So How are they formed?:**
 - **Epitope Spreading:**
 - (Autoreactive T-Cells specific to Histones, provide help not only to the original Histone-Specific B-Cells, but also DNA-Specific B-Cells → Production of both Anti-Histone & Anti-DNA antibodies)
 - **1. A Damaged/Apoptotic cell releases Nuclear Material.**
 - **2. An Autoreactive Histone-Specific B-Cell binds, endocytoses, and present it to Autoreactive CD4-Th-Cells – (Incl. Those specific to *other* Nuclear Antigens. – Eg. DNA-Specific)**
 - **3. The Histone-Specific T-Cells then help DNA-Specific B-Cells → Produce Anti-DNA Antibodies, which form complexes with Nucleosomes and Complement protein C3.**
 - **4. These complexes then deposit in the kidneys → Cause Glomerulonephritis.**
- **NB: Some Genetic Predisposition**
- Deficiency of Fas Ligand → Failure to remove Autoreactive T-Cells by Apoptosis.



Immunity Against Infectious Organisms & Evasion of the Immune Response

General Terminology:

- **Normal Flora:** ("Commensal") Bacteria consistently associated with an animal.
- **Pathogen:** A microorganism able to produce disease
- **Pathogenicity:** Ability of a Microorganism to cause disease
- **Virulence:** The *Degree* of Pathogenicity
- **Opportunistic Pathogens:** Bacteria which cause disease in a compromised host.
- **Infection:** When an organism breaches a body surface into an area where it shouldn't.
NB: Infection doesn't *necessarily* mean Disease.
- **Disease – Depends on:**
 - o Route of entry. (→Spleen/nodes/MALT/etc)
 - o Number of Infectious Bacteria
 - o Immune status of the host.

How Pathogens Cause Tissue Damage:

- **Exotoxins:**
 - o – Released by microorganisms
 - o → Act at the Surface of Host Cells (Ie. Binding to Host Receptors).
 - o Eg. Superantigens → Toxic Shock (Due to mass release of cytokines)
- **Endotoxins:**
 - o – Are Intrinsic Components of the Microbial Structure
 - o Eg. LPS → Trigger Phagocytes to release Cytokines → Septic Shock.
- **Direct Cytopathic Effect:**
 - o Many pathogens are Cytopathic → Directly damage Infected Cells.
- **Immune Complexes:**
 - o Eg. Ag:Ab Complexes deposit in the Kidneys/Microvessels/etc. → Disease.
 - Eg. Glomerulonephritis
- **Anti-Host Antibodies:**
 - o Some Bacterial Antigens (Eg. M-Protein on Streptococcus) are very similar to Host Antigens.
 - Therefore, the resultant Antibodies will cross-react with Host-Cells → Cell Damage.
- **Cell-Mediated Immunity:**
 - o Ie. T-Cells which kill infected cells.
 - o NB: Neutrophils can also cause tissue damage by Degranulation & Respiratory Bursts.

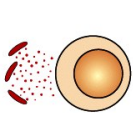
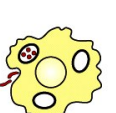
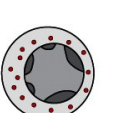
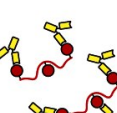

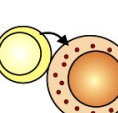
	Direct mechanisms of tissue damage by pathogens			Indirect mechanisms of tissue damage by pathogens		
	Exotoxin production	Endotoxin	Direct cytopathic effect	Immune complexes	Anti-host antibody	Cell-mediated immunity
Pathogenic mechanism						
Infectious agent	<i>Streptococcus pyogenes</i> <i>Staphylococcus aureus</i> <i>Corynebacterium diphtheriae</i> <i>Clostridium tetani</i> <i>Vibrio cholerae</i>	<i>Escherichia coli</i> <i>Haemophilus influenzae</i> <i>Salmonella typhi</i> <i>Shigella</i> <i>Pseudomonas aeruginosa</i> <i>Yersinia pestis</i>	Variola Varicella-zoster Hepatitis B virus Polio virus Measles virus Influenza virus Herpes simplex virus Human herpes virus 8 (HHV8)	Hepatitis B virus Malaria <i>Streptococcus pyogenes</i> <i>Treponema pallidum</i> Most acute infections	<i>Streptococcus pyogenes</i> <i>Mycoplasma pneumoniae</i>	<i>Mycobacterium tuberculosis</i> <i>Mycobacterium leprae</i> Lymphocytic choriomeningitis virus <i>Borrelia burgdorferi</i> <i>Schistosoma mansoni</i> Herpes simplex virus
Disease	Tonsillitis, scarlet fever Boils, toxic shock syndrome, food poisoning Diphtheria Tetanus Cholera	Gram-negative sepsis Meningitis, pneumonia Typhoid fever Bacillary dysentery Wound infection Plague	Smallpox Chickenpox, shingles Hepatitis Poliomyelitis Measles, subacute sclerosing panencephalitis Influenza Cold sores Kaposi's sarcoma	Kidney disease Vascular deposits Glomerulonephritis Kidney damage in secondary syphilis Transient renal deposits	Rheumatic fever Hemolytic anemia	Tuberculosis Tuberculoid leprosy Aseptic meningitis Lyme arthritis Schistosomiasis Herpes stromal keratitis

Figure 2-4 Immunobiology, 7ed. (© Garland Science 2008)

The Process of Infection:

- 1. Commensals (Normal Flora) are where they're meant to be.
- 2. Passive, Protective Barrier is broken → Local Infection
- 3. Innate Immune Response & Afferent Adaptive Immune Response:
 - o (Afferent Adaptive = The sensitisation phase – APCs stimulate respective T-Cells; and Th-Cells stimulate their respective B-Cells)
- 4. Efferent Adaptive Immune Response:
 - o (Efferent Adaptive = Lymphocytes differentiate into Effector Cells → Clear the Infection)

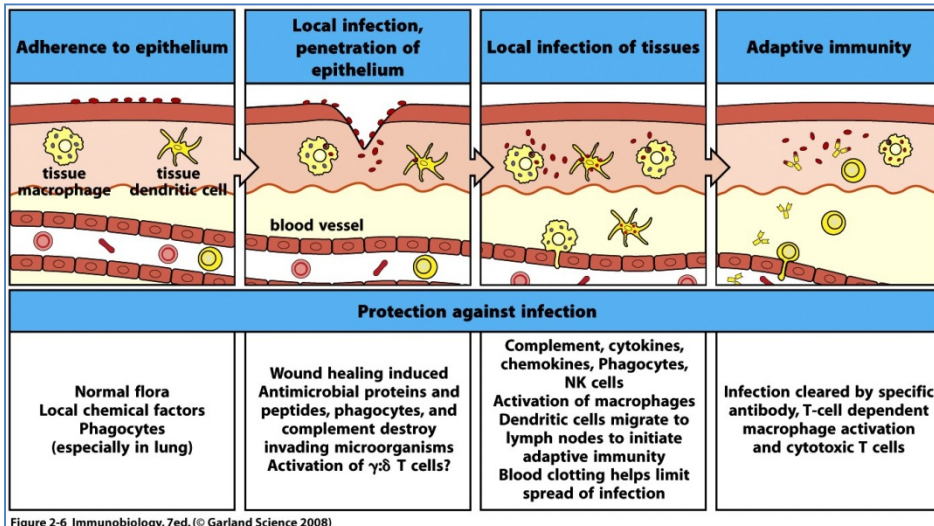


Figure 2-6 Immunobiology, 7ed. (© Garland Science 2008)

Effector Immune Functions Depend on Pathogen Location:

- **Extracellular:**
 - o NB: Virtually all Pathogens have an *Extracellular* Phase, during which they are vulnerable to the circulating molecules & cells of the Immune System (Innate & Adaptive):
 - Complement
 - Antibodies
 - Phagocytes (Macrophages, Neutrophils, Dendritic Cells)
 - o NB: These primarily aim to eliminate the Microorganism via Lysis or Promoting Phagocytosis.
- **Intracellular:**
 - o Pathogens are *Not* accessible to humoral mechanisms. Instead the Infected Cell is Attacked by:
 - Natural Killer (NK)-Cells (Innate Immune System)
 - Cytotoxic-T-Cells (Adaptive Immune System)
 - NB: Activation of Macrophages by NK/Tc-Cells induce the Macrophage to Kill their intracellular pathogens.

	Extracellular		Intracellular	
	Interstitial spaces, blood, lymph	Epithelial surfaces	Cytoplasmic	Vesicular
Site of infection				
Organisms	Viruses Bacteria Protozoa Fungi Worms	<i>Neisseria gonorrhoeae</i> <i>Mycoplasma</i> spp. <i>Streptococcus pneumoniae</i> <i>Vibrio cholerae</i> <i>Escherichia coli</i> <i>Helicobacter pylori</i> <i>Candida albicans</i> Worms	Viruses <i>Chlamydia</i> spp. <i>Rickettsia</i> spp. <i>Listeria monocytogenes</i> Protozoa	<i>Mycobacterium</i> spp. <i>Salmonella typhimurium</i> <i>Yersinia pestis</i> <i>Listeria</i> spp. <i>Legionella pneumophila</i> <i>Cryptococcus neoformans</i> <i>Leishmania</i> spp. <i>Trypanosoma</i> spp. <i>Histoplasma</i>
Protective immunity	Complement Phagocytosis Antibodies	Antimicrobial peptides Antibodies, especially IgA	NK cells Cytotoxic T cells	T-cell and NK-cell dependent macrophage activation

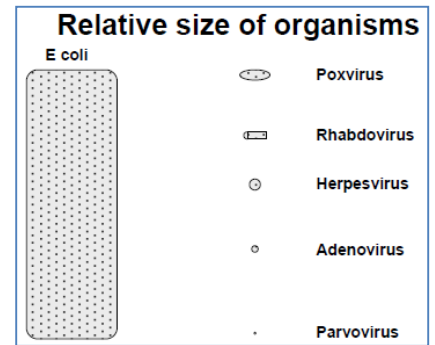
Figure 2-3 Immunobiology, 7ed. (© Garland Science 2008)

INFECTIOUS AGENTS:

VIRUSES:

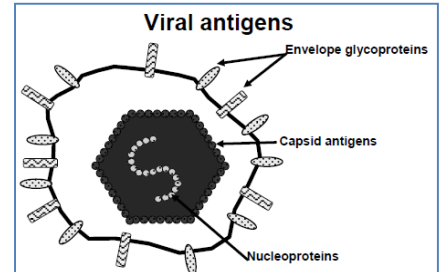
Properties of Viruses:

- Relatively Small compared to bacteria.
- Grow *Intracellularly*
- Many are *Totally Dependent* on the cell to provide Enzymes for Nucleic Acid Replication
- Some have sophisticated mechanisms for *Avoiding the Immune System*.



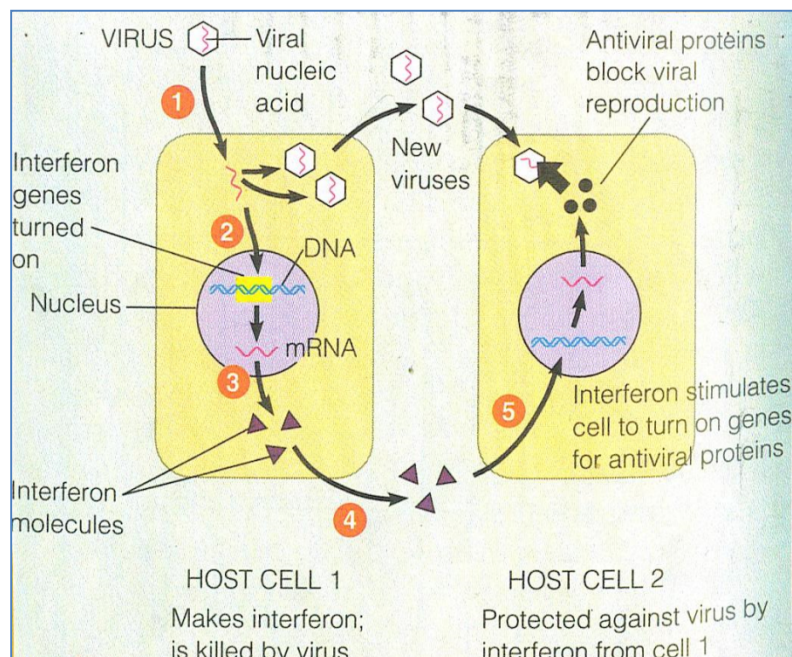
Viral Antigens:

- **May be Structural or Non-Structural:**
 - o Envelope Glycoproteins (AKA. Matrix Proteins)
 - o Capsid Antigens
 - o Nucleoproteins

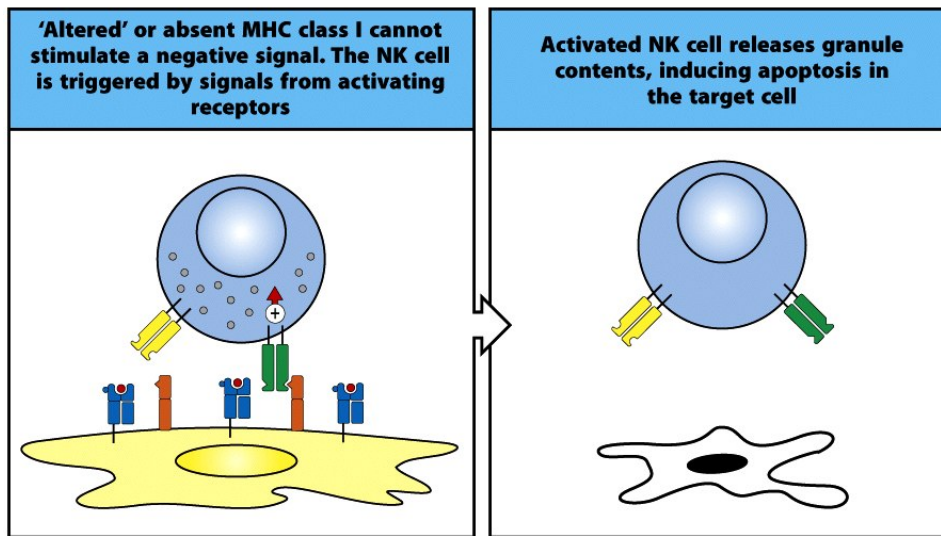


Immunity Against Viruses:

- **Innate Immunity:**
 - o *****Interferons (IFNs):**
 - **(Four Major Classes):**
 - IFN α – Produced by virally-infected WBCs.
 - IFN β – Produced by virally-infected Fibroblasts
 - IFN γ – Produced by Ag-Stimulated Effector T-Cells (Helper & Cytotoxic)
 - IFN ω – Secreted by Embryonic Trophoblasts
 - **Early, non-specific Anti-Viral Proteins (Particularly IFN- γ)**
 - Secreted by Virally Infected Cells to protect nearby cells that haven't yet been infected.
 - **Mechanism of Action \rightarrow IFN results in Synthesis of Gene Products:**
 - ****Ribonuclease:**
 - o Cleaves Viral mRNA \rightarrow Inhibits Viral Protein Synthesis & Reproduction.
 - o Allows time for Adaptive Immunity to destroy infected cells.
 - **Nitric Oxide Synthase:**
 - o Prevents viral growth in Macrophages
 - **Protein Kinase:**
 - o Prevents Elongation of Viral dsRNA
 - **Mx Protein:**
 - o Can inhibit the Transcription & Translation of some viral mRNA.
 - **Also Activates Natural Killer-Cells.**



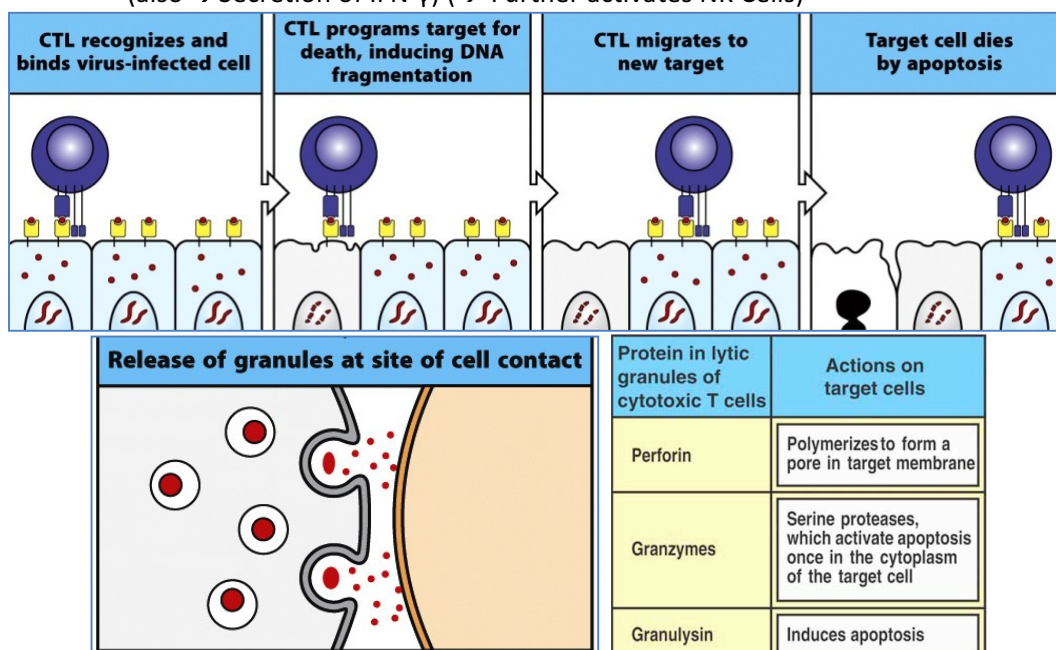
- ****Natural Killer Cells:**
 - (Activated by IFN- γ)
 - Lyse some Virally-Infected Cells.
 - Altered/Missing MHC-I \rightarrow NK cell lyses cell.



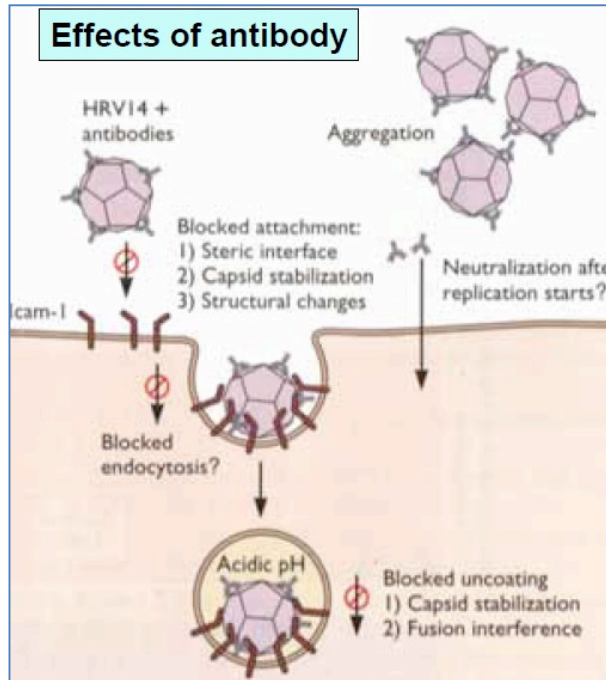
- ****Complement Activation (Alternate Pathway) & Phagocytosis of Extracellular Viruses:**
 - C3b opsonisation \rightarrow Phagocytosis
- **Lysozyme:**
 - (in Tears/Saliva/Mucus/Neutrophils)
 - Some viruses are susceptible.
- **Stomach Acid:**
 - Denatures some viruses.
- **Intestinal Enzymes:**
 - Degrade some viruses.

- **Adaptive Immunity:**

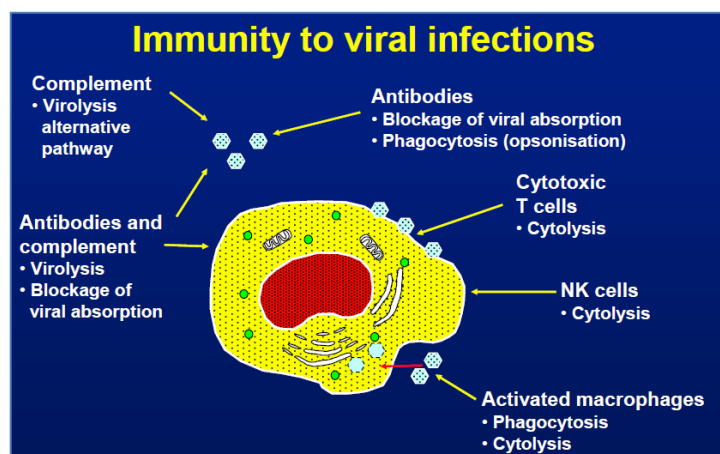
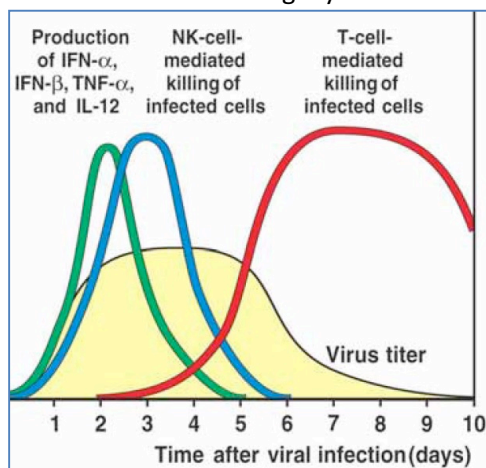
- ****Helper CD4 T-Cells:**
 - \rightarrow Secretion of IFN- γ (\rightarrow Further activates NK Cells)
 - \rightarrow Activates Macrophages \rightarrow Kill intracellular contents
 - \rightarrow Activates CD8-T-Cells \rightarrow Proliferate
- ****Cytotoxic CD8 T-Cells:**
 - Recognition of **Viral Peptide:MHC-I** \rightarrow Cytotoxic Granules line up @ site of cell contact
 - \rightarrow Apoptosis of Virally Infected Cells
 - (also \rightarrow Secretion of IFN- γ) (\rightarrow Further activates NK Cells)



- ****Antibodies:**
 - **Antibodies** → **Neutralise** Extracellular Viruses
 - (By Blocking Viral Absorption & causing Agglutination)
 - **Antibodies** → **Opsonisation** of Virus for **Phagocytosis** (Macrophages)
 - **Antibodies** → **Opsonisation** of Virus for **Antibody-Dependent Cell-Mediated Cytotoxicity**.
 - (ADCC – Fc Receptors on Cytotoxic cells bind to Antibody → Lysis of Virus)
 - **Antibodies + Complement** → **Opsonisation** of Virus for Phagocytosis (Macrophages)
 - **Antibodies + Complement** → **Virolysis** (NK Cells/T_c-Cells)
 - **Antibodies + Viral Ags on Cells** → Initiate Complement → CD8-mediated Lysis of infected cell.
 - **Antibodies + Viral Ags on Cells** → Cell-Mediated Cytotoxicity → Lysis of infected cell.



- **Activated Macrophages:**
 - (Via CD4 T-Helper Cells)
 - → Phagocytosis & destruction of Extracellular Viruses



Contribution of the Immune-Response to the Disease:

- **Destruction of Important Cells expressing Viral Antigens:**
 - Eg. Neuron Destruction → Brain Damage
 - Eg. Schwann cells Destruction → Inadequate Insulation in CNS
 - Eg. CD4-T-Helpers are destroyed in HIV Infection.
- **Immune Complexes (Ag:Ab) may deposit in Vessels/Ducts:**
 - → Glomerular Damage (Glomerulonephritis)
 - → Vascular Damage
- **IE. Sometimes the Immune Response can be more detrimental than the disease.**

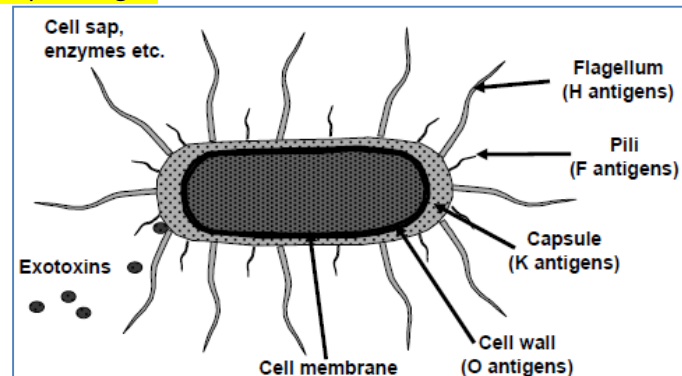
BACTERIA:

Properties of Bacteria:

- **Terminology:**
 - o **Normal Flora** = Bacteria consistently associated with an animal. (No disease)
 - o **Opportunistic Infections** = Bacteria which cause disease in a compromised host.
- **Tissue Invasion:**
 - o Some bacteria release enzymes to penetrate tissues:
 - Eg. Hylauronidase
 - Eg. Collagenase
 - Eg. Elastase
 - o Some secrete Coagulases → Induce Clotting (an environment in which they can grow).
 - o Some even invade *Cells* → Grow in the Cytoplasm/Nucleus.

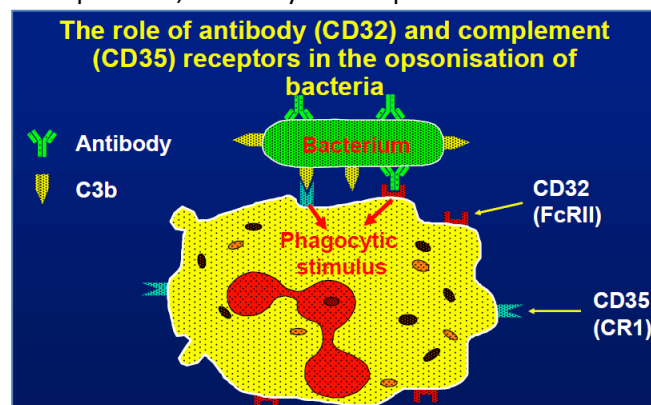
Bacterial Antigens (Virulence Factors):

- **Endotoxins – (In the Walls of Gram Negative Bacteria) → Septic Shock:**
- **(NB: Recognised by Toll-Like Receptors on Macrophages → Cytokines)**
 - o *****Lipopolysaccharide (LPS)**
 - o Surface Array Proteins (Eg. Enzymes)
 - o Flagellum
 - o Adhesion Pili
 - o Capsule Antigens
 - o Cell Wall Antigens
 - o Cell Membrane
- **Exotoxins – (Toxic Molecules Released by the Bacteria) → Toxic Shock:**
 - o Eg. Tetani Toxin
 - o Eg. Staph → **Superantigen.**

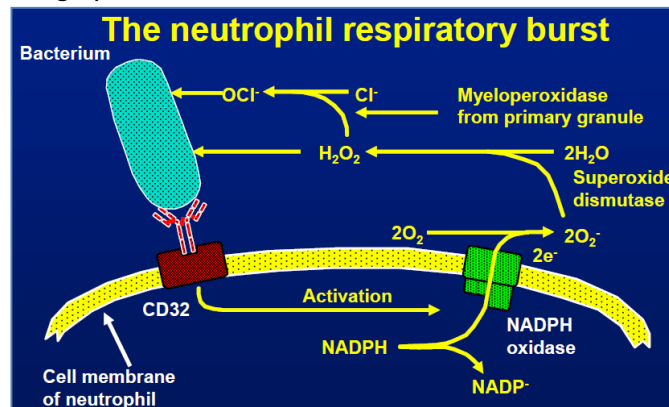


Immunity Against Bacteria:

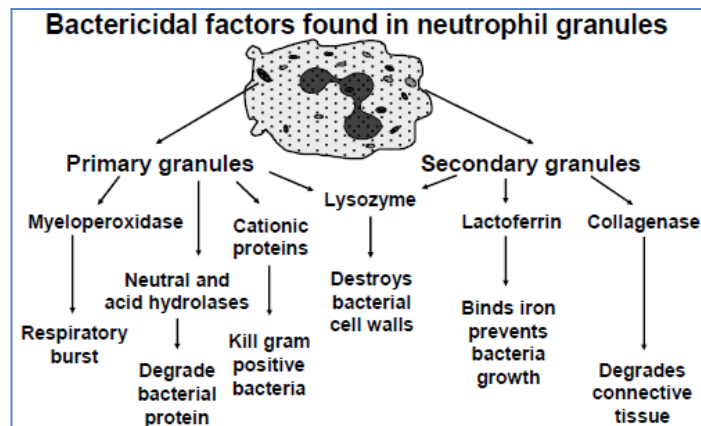
- **Innate Immunity:**
 - o ****Phagocytosis:**
 - By Macrophages/Dendritic Cells/Neutrophils
 - May be Independent, Antibody or Complement Mediated.



- ***Lysozyme:**
 - An Antibacterial enzyme dissolved in bodily secretions. (Tears/Saliva/Mucus/Neutrophils)
 - → Splits the Cell Wall Proteoglycans of Bacteria → Lysis
- ****Complement Activation – Via Alternative Pathway:**
 - → **Phagocytosis:**
 - C3b opsonisation → Phagocytosis of Bacteria.
 - → **Lysis:**
 - Membrane attack complex formation → Lysis of Bacteria.
- ****Neutrophils:**
 - → **Phagocytosis:**
 - Neutrophils ingest & kill many Microbes.
 - → **“Respiratory Burst”:**
 - Binding of Fc-portion of Antibodies on opsonised Bacteria stimulate production of Highly Oxidative Molecules which kills the bacteria.



- → **Bacteriocidal Granules:**

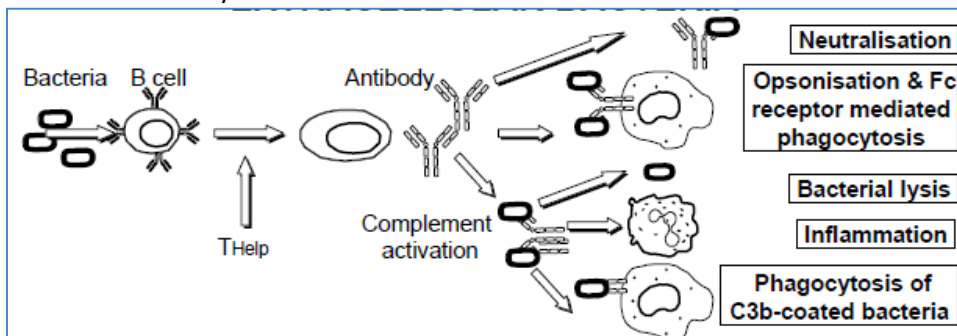


- **Local Inflammation – (Due to Cytokine Release after Macrophage Phagocytosis):**
 - → Local Inflammation
 - → Fever
 - → Acute Phase Proteins
- **Acute Phase Proteins:**
 - (C-Reactive Protein [CRP], Mannose-Binding Lectin [MBL])
 - Both are:
 - **Opsonising Agent for microbes** → Phagocytosis (Similar action to Antibodies – except have broad specificity for PAMPs)
 - **Complement Activators** → Activate the *Classical (CRP)/Lectin (MBL) Pathways of the Complement Cascade.*

Adaptive Immunity:

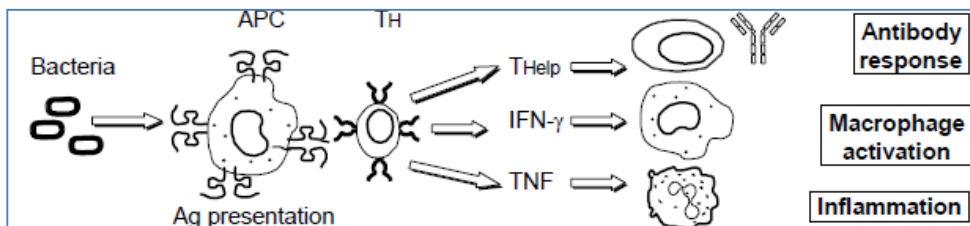
****Antibodies – (Produced by B-Cells):**

- → **Exotoxin Neutralisation:**
 - IgG is Entirely Responsible for this.
 - IgG essentially competes with the receptor for the toxin → Prevents binding to cellular target.
- → **Endotoxin Opsonisation:**
 - Fc-Receptor-Mediated Phagocytosis
- → Bacteriolysis.



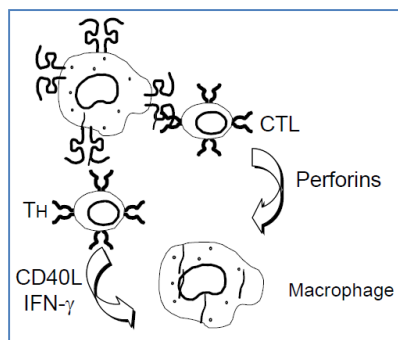
CD4-T-Helper Cells:

- → **Activate Macrophages:**
 - → Destruction of Phagocytosed Bacteria
- → **Activate B-Cells:**
 - → Secretion of Antibodies



CD8-T-Cytotoxic Cells → Kill Infected Cells:

- Infected Cells displaying bacterial peptide on MHC-I are lysed by Perforins released by Cytotoxic CD8-T-Cells.



Mechanisms of Immune Evasion:

For more details, see the section on immune evasion at the end of these notes.

(EXTRACELLULAR BACTERIA)		(INTRACELLULAR BACTERIA)	
Evasion Strategies	Examples	Evasion Strategies	Examples
Antigenic variation	<i>N. gonorrhoeae</i> , <i>E. coli</i> , <i>S. typhimurium</i>	Inhibition of phagolysosome formation	<i>M. tuberculosis</i> , <i>L. pneumophelia</i>
Inhibition of complement activation	Many bacteria	Scavenging of reactive O ₂ intermediates	<i>M. leprae</i>
Resistance to phagocytosis	Pneumococcus	Disruption of phagosome membrane, escape into cytoplasm	<i>L. monocytogenes</i>
Scavenging of reactive O ₂ intermediates	Catalase-positive staphylococci		

PARASITES:

Properties of Parasites:

- Parasites in General:

- Lives at the expense of their host → Acquires Nutrients/Other Benefits without Reciprocal Benefits.
- Are Successful if:
 - Produces minimal disturbance
 - Not regarded by host as foreign
- Parasite infections tend to be Long-Term (As opposed to Bacteria/Viruses)
- Many make use of the Host's growth-factors to promote their *own* growth.
- **(Incl. Protozoa, Metazoa [Helminths/Worms] & Arthropods):**

Protozoa

Unicellular, either intracellular (for example, malaria) or extracellular (for example, African trypanosomes). Malaria kills over 1 million per year.



Leishmania mexicana

Helminths

Multicellular, metazoan worms; includes round-worms (nematodes), schistosomes and tape-worms. Over 25% of global population infected.



Heligmosomoides polygyrus



Ixodes hexagonus

Ectoparasites

Lice, mites, ticks and other arthropods.

Immunity Against Parasites:

- Innate Immunity:

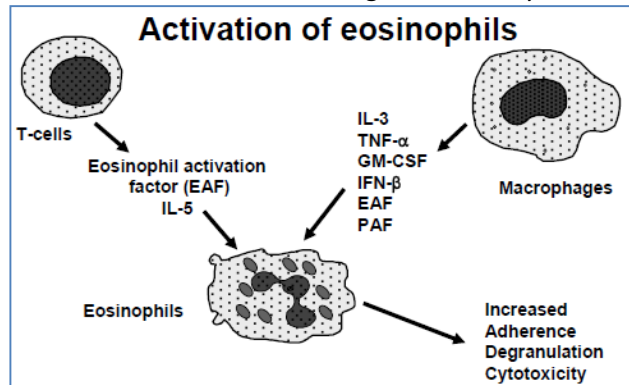
- **Lysozyme:**
 - (in Tears/Saliva/Mucus/Neutrophils)
 - Some parasites are susceptible.
- **Eosinophils (Eosinophil Granulocytes):**
 - Combat multicellular Parasites.
 - Degranulate → Release Reactive Oxygen Species → to kill parasites.
- **Complement Activation:**
 - By Alternate Pathway – Complement Activation by Binding to Pathogen Surface
 - By MB-Lectin Pathway – Complement Activation by Binding to Lectin on Pathogen Surface.
 - (NB: Classical Pathway is Adaptive – Complement Activation by Ab's on Pathogen Surface)
- **Phagocytes in Spleen:**
 - Infected RBCs express specific Parasite Antigens which are opsonised by antibody/complement → Recognised & Removed by Phagocytes in the Spleen.

- Adaptive Immunity:

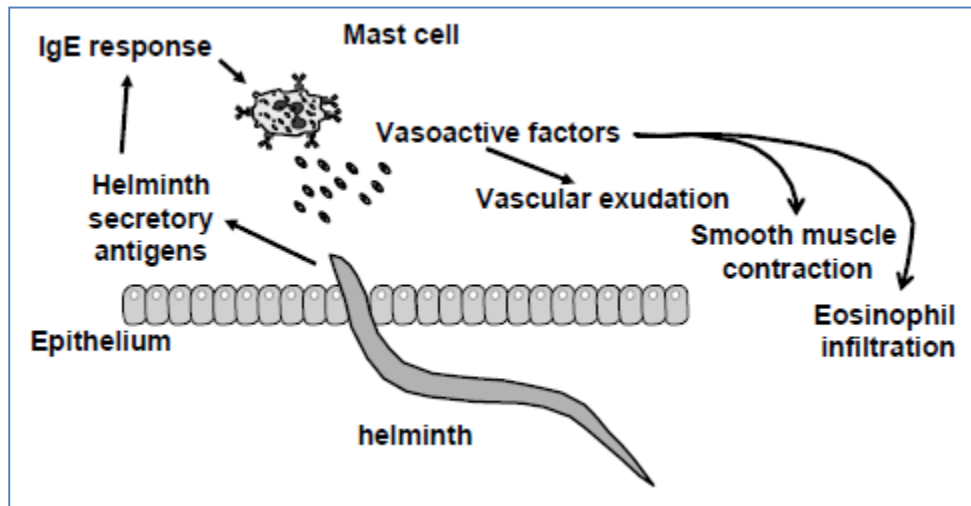
- **Antibodies (B-Cells):**
 - **Typically for Extracellular Infections (in blood/Tissues)**
 - **IgE** is the Major Isotype (Important in eliminating many helminth infections)
 - → (Hence, many infections are associated with **Type-1 Hypersensitivity** reactions.)
 - → Oedema, Asthma, Urticaria.
 - - Can destroy Tachyzoites (young parasites) in blood.
 - - Can neutralise *Proteases* used by parasites to enter tissues.
 - - Can block 'Anal Pores' of parasites.
 - - Can block enzyme pathways of some helminths (Can arrest egg production)
 - (NB: However, Many parasites are unaffected by antibodies)
 - **Complement Activation (By Classical Pathway):**
 - Complement Activation by Ab's on Pathogen Surface
 - - Can destroy Tachyzoites (young parasites) in blood.
 - **Cell-Mediated:**
 - **Typically for Intracellular Infections.**
 - **Th1-Cells Activate Macrophages:**
 - Macrophages become more Phagocytic and Destroy Intracellular Parasites.
 - (NB: Typically only Protazoan parasites are small enough to live intracellularly)
 - **Th2-Cells Help B-Cells produce Antibodies:**
 - (Th2 is the predominant response)
 - **Tc-Cells Destroy Infected Cells:**
 - May also directly destroy larvae.

○ **Eosinophils:**

- **NB: They are the MAIN Effector Cell against Helminth Infections.**
- **Activated by:**
 - Th-Cells (IL-5) & Macrophages (TNF- α , IFN- β , IL-3)
 - → Increased Adherence & Degranulation Cytotoxicity.



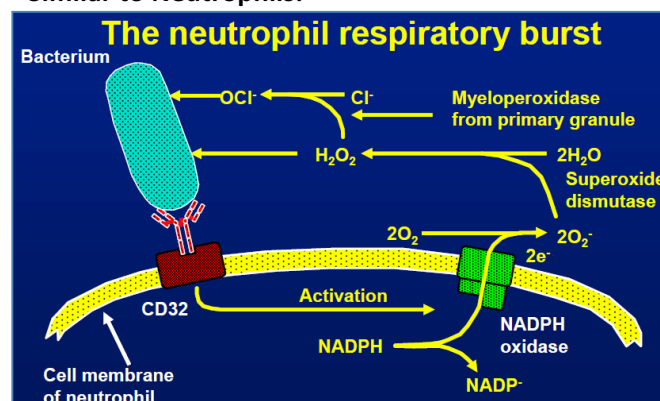
- **Eosinophils have Fc receptors (Allow binding to Parasites covered with IgE-Antibodies)**
 - Binding of Antigen to Eosinophil-Bound-IgE → Degranulation.
 - **Similar to Mast Cells:**



- **Release Granules onto the worm:**
 - ***Major Basic Protein (Damages Cuticle of Helminths)**
 - Eosinophil-Cationic Protein (A Ribonuclease – Toxic to Helminths)
 - Lysophospholipase
 - Phospholipase D

▪ **Respiratory Burst:**

- Superoxide
- Chloride Ions
- Hydrogen Peroxide
- **Similar to Neutrophils:**



IMMUNE EVASION MECHANISMS

Immune-Evasion by Various Pathogens:

(Background: Many organisms have strategies to avoid the immune response.)

	Infectious agent	Disease	Humoral immunity				Cell-mediated immunity	
			IgM	IgG	IgE	IgA	CD4 T cells (macrophages)	CD8 killer T cells
Viruses	Herpes zoster	Chickenpox	Diagonal	Diagonal	None	None	None	Diagonal
	Epstein-Barr virus	Mononucleosis	None	Diagonal	None	None	None	Diagonal
	Influenza virus	Influenza	None	Diagonal	None	Diagonal	None	Diagonal
	Polio virus	Poliomyelitis	None	Diagonal	None	Diagonal	None	Diagonal
Intra-cellular bacteria	<i>Rickettsia prowazekii</i>	Typhus	None	None	None	None	Diagonal	Diagonal
	Mycobacteria	Tuberculosis, leprosy	None	None	None	None	Diagonal	Diagonal
Extra-cellular bacteria	<i>Staphylococcus aureus</i>	Boils	Diagonal	Diagonal	None	None	None	None
	<i>Streptococcus pneumoniae</i>	Pneumonia	Diagonal	Diagonal	None	Diagonal	None	None
	<i>Neisseria meningitidis</i>	Meningitis	None	Diagonal	None	None	None	None
	<i>Corynebacterium diphtheriae</i>	Diphtheria	None	Diagonal	None	Diagonal	None	None
	<i>Vibrio cholerae</i>	Cholera	None	Diagonal	None	Diagonal	None	None
Fungi	<i>Candida albicans</i>	Candidiasis	None	Diagonal	None	None	Diagonal	None
Protozoa	<i>Plasmodium</i> spp.	Malaria	None	Diagonal	None	None	Diagonal	None
	<i>Trypanosoma</i> spp.	Trypanosomiasis	None	Diagonal	None	None	None	None
Worms	Schistosome	Schistosomiasis	None	None	Diagonal	None	Diagonal	None

Figure 10-16 Immunobiology, 7ed. (© Garland Science 2008)

Antigenic Variation:

- (I.e. Pathogens can evade detection by altering their antigens – Especially *Extracellular Pathogens*)
 - (Viruses, Bacteria & Protozoa)
- **1. Antigenic “Serotypes”:**
 - Many pathogens exist in a wide variety of Antigenic Types.
 - (Eg. Strep. **Pneumoniae** has 84 known types – each with different surface antigens)
 - (Eg. Some **Protozoa** have several *Variable Antigens*, encoded by different genes, and can *Switch* between different genes once the immune system is sensitised)
 - **Therefore**, infection with *One Serotype* leads to ‘*Type-Specific Immunity*’, which protects against reinfection of *That Same Serotype*, but NOT against a Different Serotype.

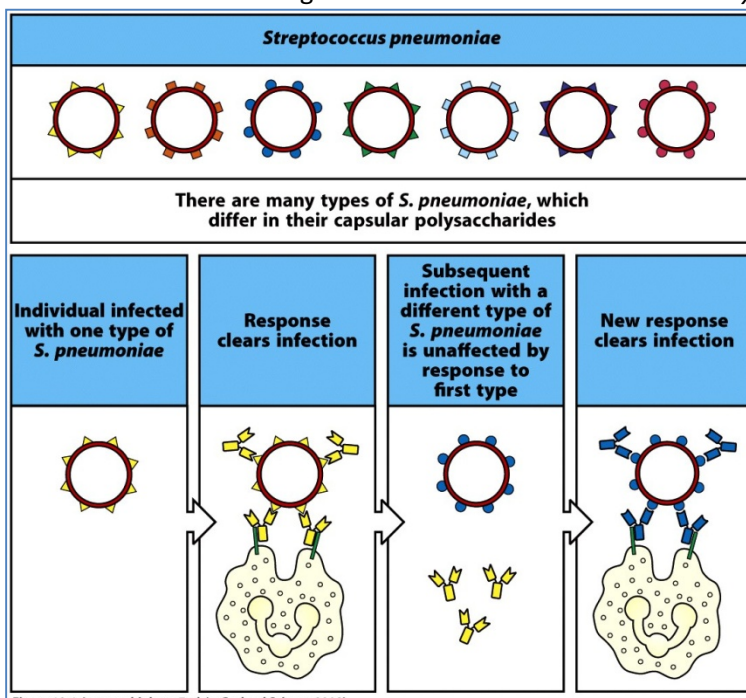
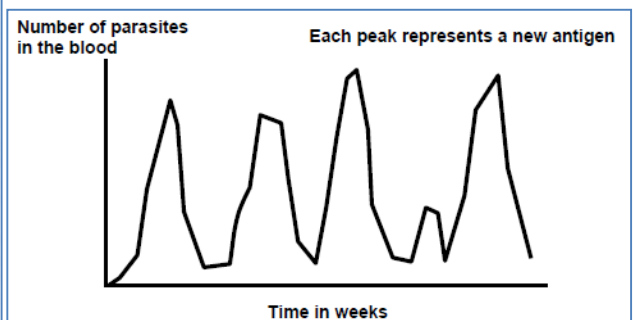
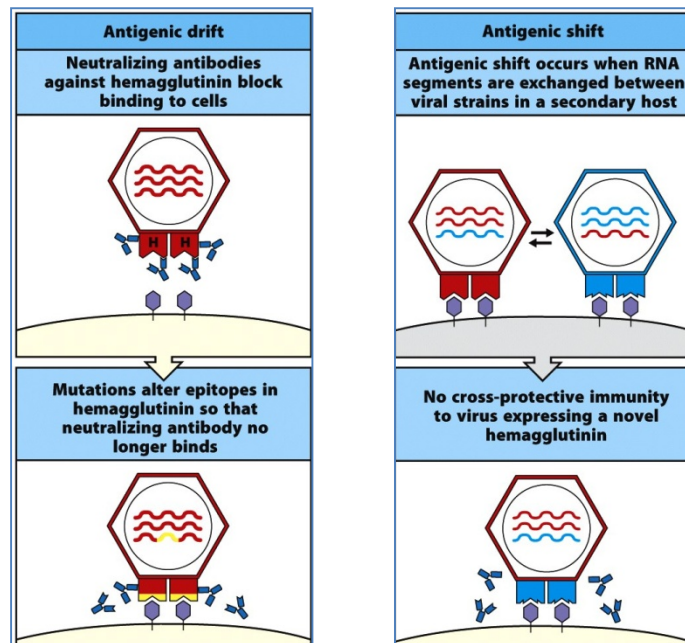


Figure 12-1 Immunobiology, 7ed. (© Garland Science 2008)

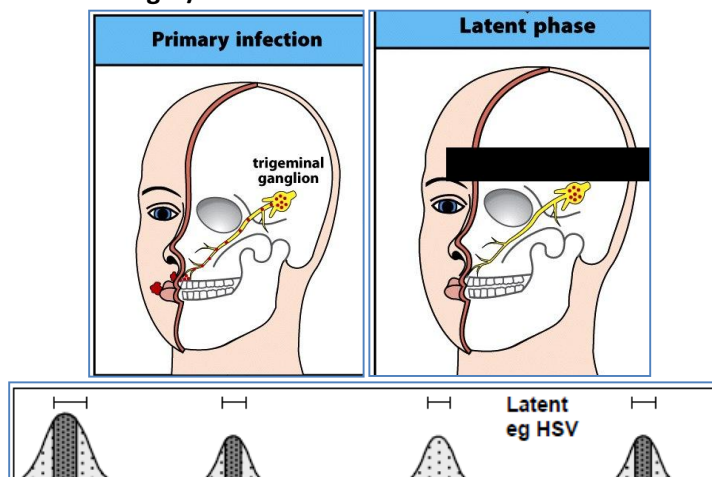


- **2. Antigenic “Drift”:** (RNA Viruses only):
 - Some Pathogens can *Mutate* Genes encoding for Surface Antigens → Change in Epitopes of Surface Antigens → Leads to Different “*Strains*” of the same pathogen.
 - (Eg. Influenza Virus – There is a new strain of Influenza Virus every 2-3 years.)
 - Therefore, Antibodies & T-Cells produced in earlier infections are *LESS* protective.
- **3. Antigenic “Shift”:** (RNA Viruses only):
 - Some Pathogens can *Exchange* Genes between their Human & Animal counterparts → Resulting in a virulent “*Hybrid-Virus*” or “*Quasispecie*” that can infect Humans.
 - (Eg. Human Influenza Virus + Swine Influenza → Human-Swine-Flu → Pandemics)
 - Therefore, Antibodies & T-Cells produced in earlier infections are *NOT* protective.
 - → Leads to Global Pandemics of Severe Disease & High Mortality.



- **Latency:**

- (I.e. Some Viruses persist *In Vivo* by Ceasing to Replicate until Immunity Wanes.)
- **Normally: Non-Latent Viruses:**
 - To replicate, viruses need to direct the synthesis of viral proteins, which can be displayed on the MHC-I molecules of the Infected Cell → CD8-T-Cell Immune Response.
- **However, Latent Viruses – Eg. Herpes Simplex Virus:**
 - Some viruses enter a state of *Latency*, where the Virus lies dormant.
 - In the latent state, there is *NO* viral Replication → *NO* Disease & *NO* Immune Response.
 - Often, such viruses persist in their *Latent State* inside *Sensory Neurons* – Which express few MHC-I molecules → Low CD8-T-Cell Recognition.
 - **Reactivation (“*Recrudescence*”)** can be triggered by **Immunosuppression/Stress/Sunlight/Hormonal Changes/etc.**



- **Resistance to Immune Effector Mechanisms:**
- **(I.e. Some pathogens induce a normal Immune Response, but have Mechanisms for Resisting them)**
 - (Viruses, Bacteria & Parasites)
 - **Eg. Preventing Fusion of Lysosome with Phagosome:**
 - **Eg. Bacteria: M.Tuberculosis** is phagocytosed, but *Blocks* fusion of Lysosome with Phagosome → Protects itself from Lysosomal Contents.
 - **Eg. Protozoa: Toxoplasma Gondii** – Tachyzoites are phagocytosed, but *Blocks* fusion of Lysosome with Phagosome → Protects itself from Lysosomal Contents.
 - **Eg. Neutralising the Respiratory Burst:**
 - **Eg. Bacteria: Pseudomonas** Produces *Superoxide Dismutase* (to neutralise Respiratory Burst Free-Radicals.) – Hence avoid Bactericidal Effects.
 - **Eg. Helminths** may also produce Antioxidants (to protect against the respiratory burst)
 - **Eg. Escaping from Phagosome into Cytoplasm of Cell:**
 - **Eg. Bacteria: Listeria** escapes from the Phagosome → Into the Cytoplasm of the Macrophage.
 - → Multiply inside the Cytoplasm of the Macrophage.
 - → They can also spread to Adjacent Cells *Without* emerging into the Extracellular Environment.
 - (I.e. Avoids attack by Antibodies, but still vulnerable to CD8-T-Cell attack)
 - **Eg. Self-Isolation by Creating its Own Vesicle:**
 - **Eg. Parasite: Toxoplasma Gondii** Generates its *OWN* Vesicle once inside the cell, and doesn't fuse with any cellular vesicle.
 - → Isolates the Parasite from the rest of the cell.
 - → Also means less peptides are available for loading onto MHC-I molecules.
 - **Eg. Molecular Mimicry:**
 - **Eg. Expression of Host-Proteins:**
 - **Eg. Bacteria: Syphilis** coats itself with *Host Proteins* while it is Extracellular.
 - → **Avoids Recognition by Effector Immune Mechanisms**
 - It also likes to invade CNS tissue (which is less accessible to antibodies).
 - **Eg. Some Schistosomes** cover themselves with *Host Proteins* (Eg. Blood-Group Antigens & MHC products)
 - → **Avoids Recognition by Effector Immune Mechanisms**
 - **Eg. Expression of the Complement-Inhibitor Protein, "Factor-H":**
 - **Eg. Bacteria: Lyme Disease** avoids Complement-Lysis by coating itself with the *Complement-Inhibitory Protein = "Factor H"*, normally made by the host.
 - **Eg. Protease Production to Neutralise Anti-Parasite Immune Components:**
 - **Eg. Shistosomula (Helminth)** Produces Proteases → Cleave Antibodies
 - They also Inhibit Macrophage Function.
 - **Host Proteases may be Inactivated by Protease Inhibitors.**

- **Immunosuppression or Inappropriate Immune Responses:**

○ **Superantigens:**

- **Superantigens (Bacterial/Viral)** – facilitate *Non-Specific* binding between TCRs & MHCs → Mass Non-Specific T-Cell Activation → Huge Release of Cytokines → “Cytokine Storm” or “Toxic Shock Syndrome”.
- **NB:** These stimulated T-Cells proliferate and then rapidly undergo *Apoptosis*:
 - → Generalised Immunosuppression
 - → Deletion of Certain Families of T-Cells.

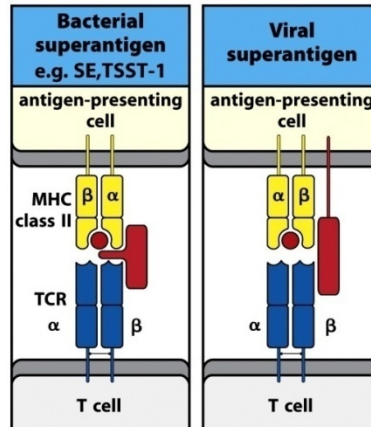


Figure 5-22 part 1 of 2 Immunobiology, 7ed. © Garland Science 2008

○ **Capturing Host Genes by Viruses:**

▪ **Eg. For Cytokines (Virokines)/Cytokine Receptors:**

- **Eg.** Some viruses direct production of Viral Cytokines (Virokines) which act as antagonists @ Cytokine Receptors → Inhibits Inflammation.
- **Eg.** Large Viruses (eg. Poxviruses) also direct production of IL-1-Receptor Analogues that Mop Up & Inactivate IL-1 → Inhibits Inflammation.

▪ **Eg. For Complement-Regulatory Molecules:**

- **Eg.** Herpes Simplex can direct production of Complement Inhibitory Proteins → which Reduce the Effects of Complement.

▪ **Eg. Inhibition of MHC-I Synthesis/Assembly:**

- **Eg.** Herpes Simplex Virus direct expression of a protein → Inhibits synthesis of MHC-I
 - Or → Inhibits MHC-I Assembly.
 - Or → Inhibits the 'TAP' → Prevents Peptide Transport into the ER → Prevents Peptide-Loading onto MHC-I.
- → Infected cells Can't Present Viral Peptides to Tc-Cells.

▪ **Eg. Production of Decoy Proteins**

- **Eg.** Human Cytomegalovirus directs expression of 'UL18', an MHC-I Analogue → Binds to Inhibitor Receptor on NK-Cells → Inhibits NK-Cells.
- **Eg.** Epstein-Barr Directs expression of IL-10 → Inhibits Th1-Lymphocytes → Reduces IFN γ Production.

○ **Eg. Anthrax Toxin – Suppresses the Immune Response:**

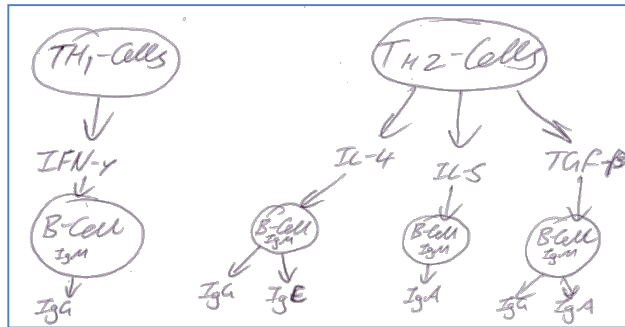
- **Bacteria: Anthracis** – suppresses the immune system via a Toxin: “Anthrax Lethal Toxin”.
 - Anthrax Lethal Toxin is a *Metalloproteinase* → Alters MAP-Kinase cascades → Apoptosis of Infected Macrophages & Abnormal Dendritic Cell Activity → Immunosuppression.

○ **Eg. Helminths – Secrete Soluble Immunosuppressant Factors:**

- → Inhibit Lymphocyte Function.
- → Inhibit Mast-Cell Degranulation.

○ **Eg. Helminths – Skew the T-Helper Response to Favour Th1-Cells:**

- By favouring the Th1-response, you don't get class-switching to IgE, the primary AntiParasitic Antibody.
- NB: Some can even *Upregulate* IL-10, → T-Regulatory-Response → ↓ Immune Response.



- **Sheltering in Immune-Privileged Sites:**

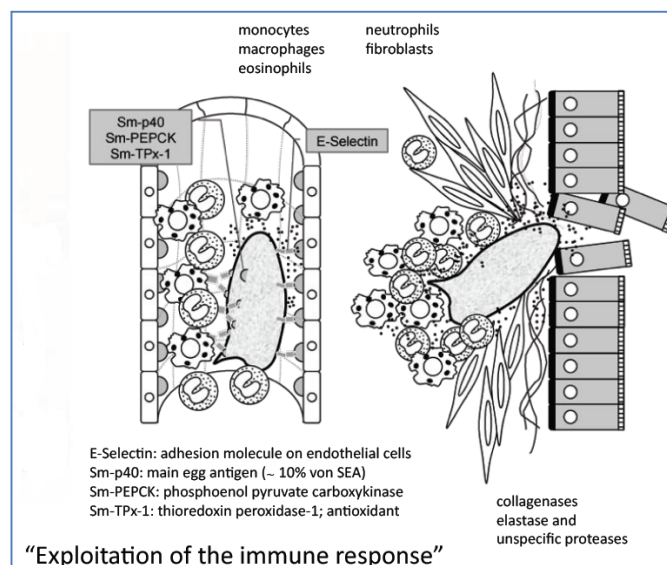
○ **(I.e. Sites where antigens CANNOT be targeted by Immune Activity)**

- Eg. Intracellular (I.e. Eg. Inside macrophages)
- Eg. Brain
- Eg. Eye
- Eg. Testis
- Eg. Uterus (Foetus)
- Eg. Vagina
- Eg. Urethra
- Eg. RBCs:
 - *Plasmodium Falciparum* (Malaria) – lives inside RBCs which don't express MHC-I:
 - → Can't be recognised by CD8-T-Cells.
 - → Are Shielded from Antibodies.
 - However, Infected RBCs *Can* be recognised/destroyed in the spleen:
 - To avoid this, Malaria Parasites cause the RBCs to become *Sticky* →
 - RBCs adhere to endothelium in peripheral organs.
 - (NB: Can lead to peripheral vasculopathies & ischaemic organ failure)
- Eg. GI-Lumen

- **Exploiting The Immune System to Aid in Life-Cycle:**

○ **Eg. Some Helminths Exploit the Increased Expression of Cell-Adhesion-Molecules in Inflammation:**

- **Eg. Helminths which lay eggs need to get the eggs out of the Blood Vessels.**
 - Therefore, by causing Inflammation, Endothelial Cells Increase CAM Expression.
 - → Eggs use these Adhesion Molecules to adhere to the Endothelium.
 - → They then secrete Collagenases/Elastases/Proteases → to Exit the Blood Vessel.



**IMMUNOLOGY Pathology:
PSYCHONEUROIMMUNOLOGY**

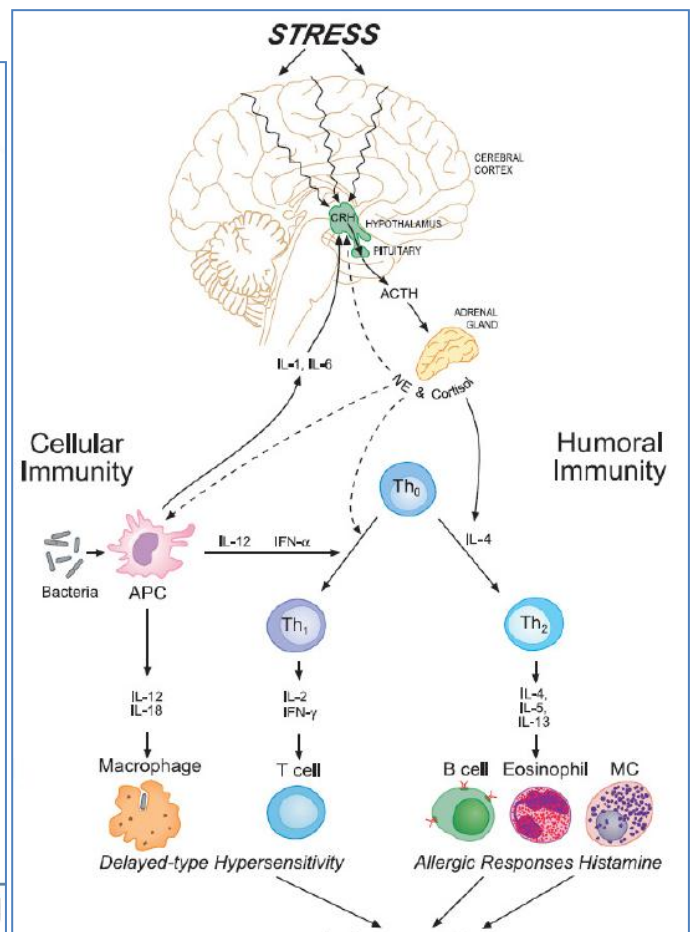
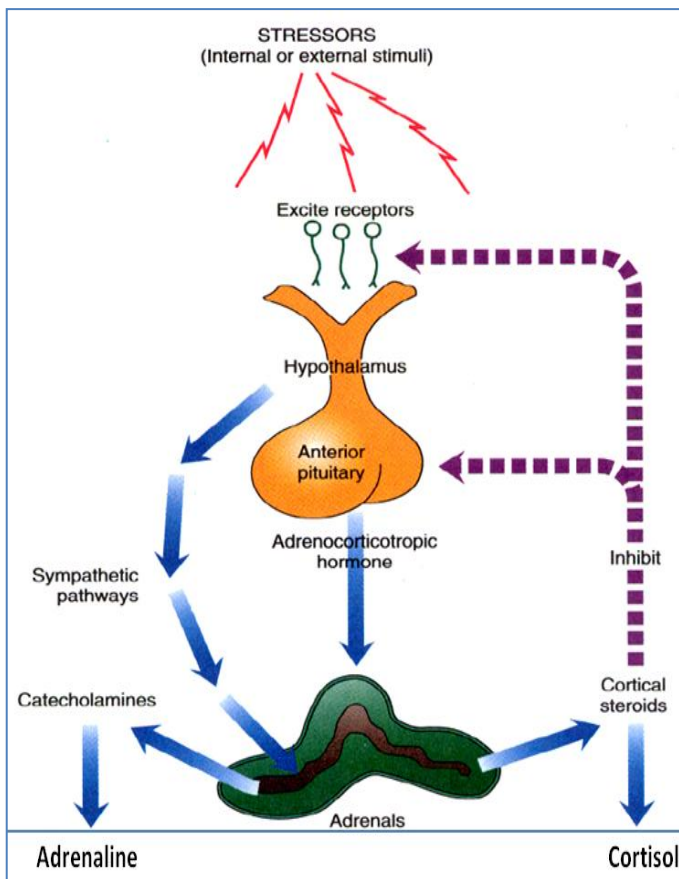
Psychoneuroimmunology (PNI):

The Brain-Endocrine-Immune System Interactions:

- **Immune Cells are Regulated by:**
 - o Neurotransmitters
 - o Hormones
 - o Neuropeptides

- **Immune Cells Communicate with Nervous Tissue through Cytokines:**
 - o – Either Local or Systemic Cytokines
 - o – Cytokines (IL1, IL6) Stimulate Peripheral Nerves → Stimulate Vagus Nerve → Stimulates Cytokine Release in CNS → Cytokines in CNS Activate Hypothalamus → Sickness Behaviour.

- **Physical/Emotional Stress & Psychiatric Illness can compromise the Immune System:**
 - o **Acute Stress ENHANCES** the Immune System, but **Chronic Stress SUPPRESSES** the Immune System:
 - 1. During Acute Stress – There is a shift towards ↑ Innate Immune Responses.
 - 2. If Chronic Stress – There is a Decrease in almost all functional Immune Responses
 - (Hence: Increase in Stressor Duration → Shifts from Adaptive to Detrimental.)
 - o **Some Hormones are Immunostimulatory:**
 - Prolactin & Growth Hormone
 - o **Stress Hormones (Adrenocortical & Glucocorticoid) are Immunosuppressive & Anti-Inflammatory:**
 - Stress → CRH Release from Hypothalamus
 - CRH → ACTH Release from Pituitary
 - o ACTH → **Noradrenaline & Cortisol** Release from Adrenal Gland.



↓ Adaptive Immune Response; ↑ Innate Immune Response



**Continue Reading For Bonus
Supplementary Study Materials...**

Susan Armstrong and Amy Miles, chapter editors

Hart Stadnick and Kevin Yau, associate editors

Alex Cressman, EBM editor

Dr. Arthur Bookman, Dr. Simon Carette, and Dr. Natasha Gakhal, staff editors

Anatomy of Joint Pathology	2	Seronegative Rheumatic Disease	21
Basics of Immunology	2	Ankylosing Spondylitis	
Immune Mechanisms of Disease		Enteropathic Arthritis	
Immunogenetics and Disease		Psoriatic Arthritis	
		Reactive Arthritis	
Differential Diagnoses of Common Presentations	3	Crystal-Induced Arthropathies	25
Synovial Fluid Analysis	4	Gout	
Septic Arthritis	4	Pseudogout (Calcium Pyrophosphate Dihydrate Disease)	
Degenerative Arthritis: Osteoarthritis	5	Non-Articular Rheumatism	27
Seropositive Rheumatic Disease	6	Polymyalgia Rheumatica	
Connective Tissue Disorders	8	Fibromyalgia	
Rheumatoid Arthritis		Adult Onset Still's Disease	
Systemic Lupus Erythematosus		Common Medications	30
Antiphospholipid Antibody Syndrome		Landmark Rheumatology Trials	31
Scleroderma (i.e. Systemic Sclerosis)		References	32
Idiopathic Inflammatory Myopathy			
Sjögren's Syndrome			
Mixed Connective Tissue Disease			
Overlap Syndrome			
Vasculitides	17		
Small Vessel Non-ANCA Associated Vasculitis			
Small Vessel ANCA-Associated Vasculitis			
Medium Vessel Vasculitis			
Large Vessel Vasculitis			

Acronyms

Ab	antibody	dsDNA	double stranded DNA	PM	polymyositis
ACPA	anti-citrullinated protein antibodies	EA	enteropathic arthritis	PMN	polymorphonuclear leukocyte
Ag	antigen	ECASA	enteric-coated acetylsalicylic acid	PMR	polymyalgia rheumatica
ANA	antinuclear antibody	ESR	erythrocyte sedimentation rate	PsA	psoriatic arthritis
ANCA	antineutrophil cytoplasmic antibody	GC	Neisseria gonorrhoeae/gonococcus	PTT	partial thromboplastin time
Anti-RNP	antinuclear protein	GCA	giant cell arteritis	PUD	peptic ulcer disease
Anti-Smith	anti-Smith antibodies	GPA	granulomatosis with polyangiitis	RA	rheumatoid arthritis
APLA	antiphospholipid antibody syndrome	H/A	headache	RBC	red blood cell
AS	ankylosing spondylitis	Hb	hemoglobin	ReA	reactive arthritis
AVN	avascular necrosis	HLA	human leukocyte antigen	RF	rheumatoid factor
BUN	blood urea nitrogen	IA	intra-articular	ROM	range of motion
CBC	complete blood count	IBD	inflammatory bowel disease	SI	sacroiliac
CCB	calcium channel blocker	IE	infective endocarditis	SLE	systemic lupus erythematosus
CCP	cyclic citrullinated peptide	ILD	interstitial lung disease	SNRI	serotonin-norepinephrine reuptake inhibitors
CMC	carpometacarpal joint	ITP	idiopathic thrombocytopenic purpura	SS	Sjögren's syndrome
CNS	central nervous system	MCP	metacarpal phalangeal joint	SSA	Sjögren's syndrome antigen A
CTD	connective tissue disease	MCTD	mixed connective tissue disease	SSB	Sjögren's syndrome antigen B
CPPD	calcium pyrophosphate dihydrate	MHC	major histocompatibility complex	TNF	tumour necrosis factor
CRP	C-reactive protein	MPO	myeloperoxidase	U/A	urinalysis
DEXA	dual energy X-ray absorptiometry	MTP	metatarsal phalangeal joint	ULN	upper limit of normal
DIP	distal interphalangeal joint	MTX	methotrexate	U-SpA	undifferentiated spondyloarthropathy
DM	diabetes mellitus	OA	osteoarthritis	VDRL	venereal disease research laboratory
DMARD	disease-modifying anti-rheumatic drug	PAN	polyarteritis nodosa	WBC	white blood cell
DMM	dermatomyositis	PIP	proximal interphalangeal joint		

Anatomy of Joint Pathology

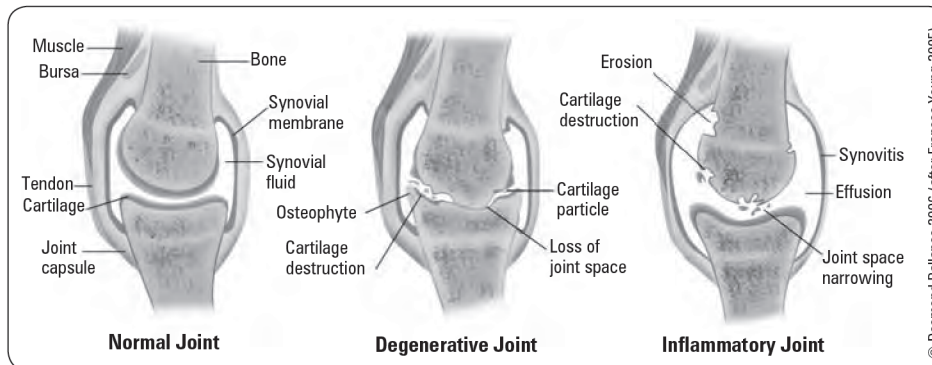


Figure 1. Structure of normal, degenerative, and inflammatory joint

Basics of Immunology

Immune Mechanisms of Disease

Table 1. Mechanisms of Immunologically Mediated Disorders

Type	Pathophysiology	Examples
Immediate Hypersensitivity (Type I)	Formation of IgE → release of immunologic mediators from basophils/mast cells → diffuse inflammation	Asthma Allergic rhinitis Anaphylaxis
Cytotoxic (Type II)	Formation of Ab → deposit and bind to Ag on cell surface → phagocytosis or lysis of target cell	Autoimmune hemolytic anemia, Goodpasture's syndrome, Graves' disease, pemphigus vulgaris, rheumatic fever, ITP
Immune Complex (Type III)	Formation and deposition of Ag-Ab complexes → activate complement → leukocyte recruitment and activation → tissue injury	SLE, PAN, post-streptococcal glomerulonephritis, serum sickness, viral hepatitis
Cell-Mediated/Delayed Hypersensitivity (Type IV)	Release of cytokines by sensitized T-cells and T-cell mediated cytotoxicity	Contact dermatitis, insect venom, mycobacterial proteins

Immunogenetics and Disease

- cell surface molecules called HLAs play a role in mediating immune reactions
- MHC are genes on the short arm of chromosome 6 that encode HLA molecules
- certain HLA haplotypes are associated with increased susceptibility to autoimmune diseases

Table 2. Classes of MHCs

MHC Class	Types	Location	Function
I	HLA-A, B, C	All cells	Recognized by CD8+ (cytotoxic) T-lymphocytes
II	HLA-DP, DQ, DR	Ag presenting cells (mononuclear phagocytes, B cells, etc.)	Recognized by CD4+ (helper) T-lymphocytes
III	Some components of the complement cascade	In plasma	Chemotaxis, opsonization, lysis of bacteria and cells

Table 3. HLA-Associated Rheumatic Disease

HLA Type	Associated Conditions	Comments
B27	AS ReA EA	In AS, relative risk = 70-90x In ReA, relative risk = 40x
DR4, DR1	RA	In RA, relative risk = 2-10x; found in 93% of patients
DR3	SS SLE	DR3 associated with many non-rheumatic conditions (celiac disease, type 1 DM, Graves' disease, chronic active hepatitis)



Terminology in Rheumatology

Arthritis

- Joint swelling: effusion/synovial thickening
- Decreased ROM
- Stress pain (pain at the end of ROM)
- Increased warmth

Arthralgia: perception of joint pain without obvious clinical findings

Active Joint: swollen joint, joint line tenderness, or stress pain



Innate Immune Cells

- Neutrophil (PMN):** circulate in blood and respond to inflammatory stimuli, kill invading organisms by phagocytosis, degranulation and neutrophil extracellular traps
- Natural Killer Cell:** innate immunity against intracellular infections (especially viruses), killing function and produce cytokines
- Macrophage:** arrive after PMNs, suppress PMN efflux and phagocytose PMN debris, secrete pro-inflammatory cytokines in response to microbial debris
- Dendritic Cell:** actively phagocytic when immature, activated by signals from toll-like receptor (TLR), release pro-inflammatory cytokines, present antigens to T cells in lymph nodes
- Cosinophil:** respond to inflammatory cytokines and degranulate releasing reactive oxygen species, and cytokines, associated with allergy, asthma and parasitic infection
- Mast Cell:** present in connective tissue and mucosa, allergen cross-linking of IgE bound to mast cell triggers degranulation and release of inflammatory mediators



Adaptive Immune Cells

- B Cell:** produce antibodies after activation by specific antigen and B-cell co-receptor, additional signals provided by CD4 T helper cells
- Cytotoxic T Cell:** CD8, direct cytotoxicity of target cells at sites of infection, kill via lytic granules and FasL-Fas interaction, recognize specific antigen and MHC1
- Helper T Cell:** subset of CD4 cells, activate and help other types of cells carry out immune defense (activate macrophages, help B cells, release cytokines)
- Regulatory T Cell:** Subset of CD4 cells, suppress activation of naive autoreactive T cells



Key Cytokine Targets of Biologic Drugs

TNF

- Source:** T cells, macrophages
- Major Functions:** cachexia, induces other cytokines, T cell stimulation, induces metalloproteinases and prostaglandins, increases expression of adhesion molecules, increases vascular permeability leading to increased entry of IgG, complement and cells into tissues

IL-6

- Source:** Many cells
- Major Functions:** proliferation of B and T cells, acute phase reactant, induces natural protease inhibitor

Differential Diagnoses of Common Presentations

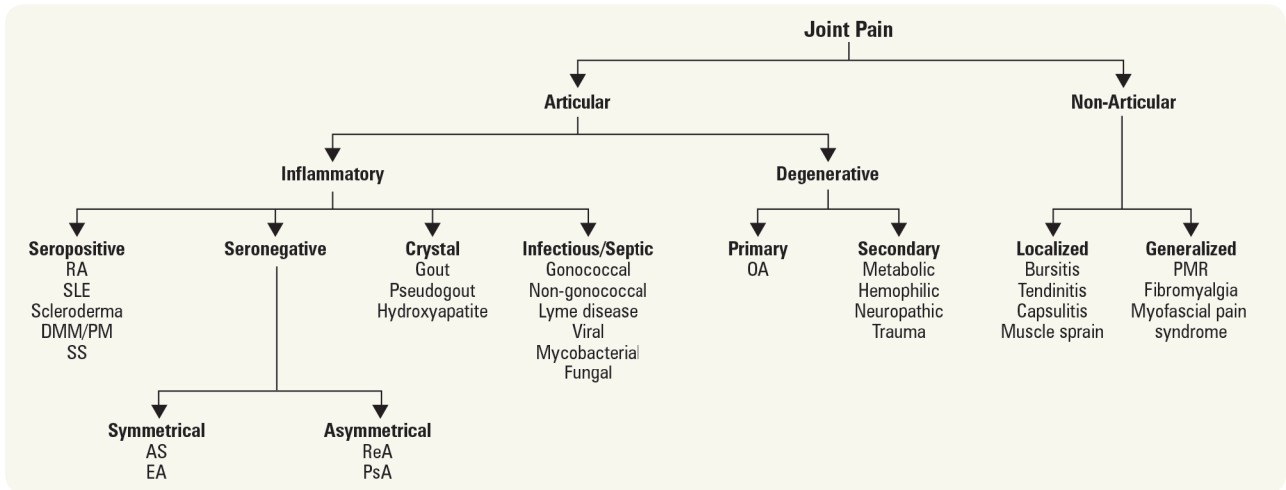


Figure 2. Clinical approach to joint pain

Table 4. Differential Diagnosis of Monoarthritis

Infection	Crystal	Degenerative	Trauma	Neoplastic	Other
Septic arthritis (<i>S. aureus</i> , GC, fungi, TB)	Gout Pseudogout Hydroxyapatite	OA	Hemarthrosis Osteonecrosis	Tumour	Systemic inflammatory disease Polyarthritis presenting with monoarticular symptoms first

Table 5. Differential Diagnosis of Oligoarthritis/Polyarthritis

Acute (<6 wk)	Chronic (>6 wk)		
First presentation or flare of inflammatory arthritis Post-viral (parvovirus B19) Acute rheumatic fever Infectious (GC, non-GC) Gout Sarcoidosis Lyme disease HIV	Seropositive inflammatory arthritis RA SLE Scleroderma DMM/PM	Seronegative inflammatory arthritis AS EA PsA ReA Crystal (polyarticular gout)	Degenerative OA

Table 6. Symptoms of Inflammatory Arthritis vs. Degenerative Arthritis

Inflammatory	Degenerative
Pain at rest, relieved by motion Morning stiffness >1 h Warmth, swelling, erythema Malalignment/deformity Extra-articular manifestations Nighttime awakening	Pain with motion, relieved by rest Morning stiffness <1/2 h Joint instability, buckling, locking Bony enlargement, malalignment/deformity Evening pain

Table 7. Seropositive vs. Seronegative Rheumatic Diseases

	Seropositive	Seronegative
Demographics	F>M	M>F
Peripheral Arthritis	Symmetrical Small (PIP, MCP) and medium joints (wrist, knee, ankle, elbow) common DIP less often involved	Usually asymmetrical Usually larger joints, lower extremities (exception: PsA) DIP in PsA Dactylitis ("sausage digit")
Pelvic/Axial Disease	No (except for C-spine)	Yes
Enthesitis	No	Yes
Extra-Articular	Nodules Vasculitis Sicca Raynaud's phenomenon	Iritis (anterior uveitis) Oral ulcers Gastrointestinal Dermatologic features



Causes of Joint Pain

- SOFTER TISSUE**
Sepsis
OA
Fracture
Tendon/muscle
Epiphyseal
Referred
Tumour
Ischemia
Seropositive arthritides
Seronegative arthritides
Urate (gout)/other crystal
Extra-articular rheumatism (PMR/fibromyalgia)



Patterns of Joint Involvement

- Symmetrical vs. asymmetrical
- Small vs. large
- Mono vs. oligo (2-4 joints) vs. polyarticular (>5 joints)
- Axial vs. peripheral



The presence of synovitis often indicates articular as opposed to non-articular joint pain; synovitis presents with: soft tissue swelling, effusion, warmth, and pain with movement

Common Investigations in Rheumatology

- general: CBC, electrolytes, Cr
- acute phase reactants: ESR, CRP, ferritin, albumin, fibrinogen, platelets
- complement (C3, C4)
- U/A to detect disease complications (proteinuria, active sediment)
- serology: see Table 10
- synovial fluid analysis
- radiology (plain film x-ray, CT, MRI, U/S, bone densitometry, angiography, bone scan)

Synovial Fluid Analysis

- synovial fluid is an ultrafiltrate of plasma plus hyaluronic acid; it lubricates joint surfaces and nourishes articular cartilage

Indications

- diagnostic: mandatory if septic arthritis suspected; advised if crystal arthritis or hemarthrosis suspected; advised if unexplained effusion in accessible joint
- therapeutic: drainage of blood, purulent or tense effusions; corticosteroid injection

Contraindications

- absolute: open lesion or suspected infection of overlying skin or soft tissue
- relative: bleeding diathesis, thrombocytopenia, prosthetic joint

Synovial Fluid Analysis

- ensure synovial fluid is described in terms of colour, clarity, viscosity, and quantity
- culture and gram stain (bacteria, mycobacteria, fungi)
- if only have 1 mL of fluid, prioritize culture and gram stain
- cell count and differential
- crystal examination (microscopy with polarized light)
 - gout (monosodium urate) → needle-shaped, negatively birefringent (bright yellow)
 - pseudogout (CPPD) → rhomboid-shaped, positively birefringent (pale blue)

Table 8. Synovial Fluid Analysis

Parameter	Normal	Non-Inflammatory	Inflammatory	Infectious	Hemorrhagic
Colour	Pale yellow	Pale yellow	Pale yellow	Yellow to white	Red/brown
Clarity	Clear	Clear	Opaque	Opaque	Sanguinous
Viscosity	High (due to hyaluronic acid)	High	Low	Low or paradoxically high if purulent	Variable
WBC/mm³	<200	<2,000	>2,000	Higher cell counts (particularly >50,000) suggestive	Variable
% PMN	<25%	<25%	>25%	>75%	Variable
Culture/ Gram Stain	–	–	–	Usually positive	–
Examples		Trauma OA Neuropathy Hypertrophic – arthropathy	Seropositives Seronegatives Crystal arthropathies	<i>S. aureus</i> Gram negative GC → difficult to culture	Trauma Hemophilia

Septic Arthritis

- for any acute monoarthritis or flare of pre-existing arthritis, one must rule out septic etiology; consider empiric antibiotic treatment until septic arthritis is excluded by history, physical exam, and synovial fluid analysis
- major bacteria are gram positive cocci (75-80%) especially *S. aureus*, and gram-negative bacilli (15-20%)
- poor prognostic factors: older age, immunocompromised, delay in treatment, previously damaged joint, joint prosthesis
- see [Infectious Diseases](#) for *Gonococcal Arthritis*, ID15 and [Orthopedics](#), OR10



ESR

- Advantages**
 Much clinical information
 May reflect overall health status
- Disadvantages**
 Affected by age and gender
 Affected by RBC/morphology/anemia/polycythemia
 Reflects many plasma proteins
 Responds slowly to inflammatory stimulus
 Requires fresh sample



CRP

- Advantages**
 Unaffected by age/gender
 Rapid response to inflammatory stimulus
 Wide range of clinically relevant values
 Can be measured on stored sera
 Quantification precise/reproducible
- Disadvantages**
 More expensive



Most Important Tests of Synovial Fluid (3 Cs)

1. Culture and gram stain
2. Cell count and differential
3. Crystal examination (protein, LDH, glucose less helpful)



Choosing Wisely Canada Recommendations

1. Do not order ANA as a screening test in patients without specific signs or symptoms of SLE or another CTD
2. Do not order an HLA-B27 unless spondyloarthritis is suspected based on specific signs or symptoms
3. Do not repeat DEXA scans more often than every 2 years
4. Do not prescribe bisphosphonates for patients at low risk of fracture
5. Do not perform whole body bone scans (e.g. scintigraphy) for diagnostic screening for peripheral and axial arthritis in the adult population



Septic arthritis is a medical emergency; it leads to rapid joint destruction, and there is a 10-15% risk of mortality



Degenerative Arthritis: Osteoarthritis

Definition

- progressive deterioration of articular cartilage and surrounding joint structures caused by genetic, metabolic, biochemical, and biomechanical factors with secondary components of inflammation

Classification (based on etiology)

- primary (idiopathic)
 - most common, unknown etiology
- secondary
 - post-traumatic or mechanical
 - post-inflammatory (e.g. RA) or post-infectious
 - heritable skeletal disorders (e.g. scoliosis)
 - endocrine disorders (e.g. acromegaly, hyperparathyroidism, hypothyroidism)
 - metabolic disorders (e.g. gout, pseudogout, hemochromatosis, Wilson's disease, ochronosis)
 - neuropathic (e.g. Charcot joints)
 - ♦ atypical joint trauma due to peripheral neuropathy (e.g. DM, syphilis)
 - AVN
 - other (e.g. congenital malformation)

Pathophysiology

- the process appears to be initiated by abnormalities in biomechanical forces and/or, less often, in cartilage
- elevated production of pro-inflammatory cytokines is important in OA progression
- tissue catabolism > repair
- genetic, environmental, mechanical loading, age and gender factors contribute, but mechanism is unknown
- now considered to be a systemic musculoskeletal disorder rather than a focal disorder of synovial joints

Epidemiology

- most common arthropathy (accounts for ~75% of all arthritis)
- increased prevalence with increasing age (35% of 30 yr olds, 85% of 80 yr olds)

Risk Factors

- genetic predisposition, advanced age, obesity (for knee and hand OA), female, trauma

Signs and Symptoms

- localized to affected joints (not a systemic disease)
- pain is often insidious, gradually progressive, with intermittent flares and remissions, neuropathic pain may also be present
- fatigue, poor sleep, impact on mood (depression, anxiety)

Table 9. Signs and Symptoms of OA

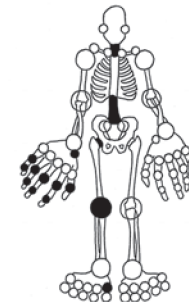
Signs	Symptoms
Joint line tenderness; stress pain ± joint effusion	Joint pain with motion; relieved with rest
Bony enlargement at affected joints	Short duration of stiffness (< 1/2 h) after immobility
Malalignment/deformity (angulation)	Joint instability/buckling
Limited ROM	Joint locking due to "joint mouse" (bone or cartilage fragment)
Crepitus on passive ROM	Loss of function or other internal derangements (e.g. meniscal tear)
Inflammation (mild if present)	
Periarticular muscle atrophy	

Joint Involvement

- asymmetric (knees usually affected bilaterally)
- hand
 - DIP (Heberden's nodes = osteophytes → enlargement of joints)
 - PIP (Bouchard's nodes)
 - CMC (usually thumb squaring)
 - 1st MCP (other MCPs are usually spared)
- hip
 - usually presents as groin pain ± dull or sharp pain in the trochanteric area, internal rotation and abduction are lost first
 - pain can radiate to the anterior thigh, but generally does not go below the knee
- knee
 - initial narrowing of one compartment, medial > lateral; seen on standing x-rays, often patellar-femoral joint involved



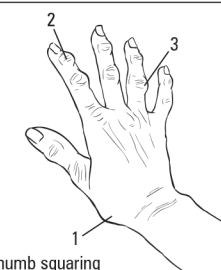
Obesity is linked to OA in the knee as well as CMC, which suggests a systemic inflammatory component to OA



- Hand (DIP, PIP, 1st CMC)
- Hip
- Knee
- 1st MTP
- L-spine (L4-L5, L5-S1)
- C-spine
- Uncommon: ankle, shoulder, elbow, MCP, rest of wrist

© Linda Colati

Figure 3. Common sites of joint involvement in OA



1. Thumb squaring
2. Heberden's nodes
3. Bouchard's nodes

© Tabby Lullham 2011

Figure 4. Hand findings in OA



OA of MCP joints can be seen in hemochromatosis or chondrocalcinosis



Hint: Bouchard's is closer to the Body



The Radiographic Hallmarks of OA

- Joint space narrowing
- Subchondral sclerosis
- Subchondral cysts
- Osteophytes

- foot
 - common in first MTP and midfoot
- lumbar spine
 - very common, especially L4-L5, L5-S1
 - degeneration of intervertebral discs and facet joints
 - reactive bone growth can contribute to neurological impingement (e.g. sciatica, neurogenic claudication) or spondylolisthesis (forward or backward movement of one vertebra over another)
- cervical spine
 - commonly presents with neck pain that radiates to scapula, especially in mid-lower cervical area (C5 and C6)

Investigations

- blood work
 - normal CBC and ESR, CRP
 - negative RF and ANA
- radiology: 4 hallmark findings
- synovial fluid: non-inflammatory (see Table 8)

Treatment

- presently no treatment alters the natural history of OA
- prevention: prevent sports injury, healthy weight management
- **non-pharmacological therapy**
 - weight loss (minimum 5-10 lb loss) if overweight
 - physiotherapy: heat/cold, low impact exercise programs
 - occupational therapy: aids, splints, cane, walker, bracing
- **pharmacological therapy** (see Table 32)
 - oral: acetaminophen/NSAIDs, glucosamine ± chondroitin (nutraceuticals not proven)
 - treat neuropathic pain if present (anti-depressants, anti-epileptics, etc.)
 - joint injections: corticosteroid, hyaluronic acid (questionable benefit)
 - topical: capsaicin, NSAIDs
- **surgical treatment**
 - joint debridement, osteotomy, total and/or partial joint replacement, fusion (see [Orthopedics](#), OR30)



Seropositive Rheumatic Disease

- diagnosis vs. classification in rheumatology
 - diagnostic criteria are often dependent on disease progression and evolution over time, as early objective measures are often unavailable
 - classification criteria are derived from studying patients with long-term diseases and clear diagnoses in order to determine which criteria have good specificity in the early prediction of certain diagnoses
- seropositive arthropathies are characterized by the presence of a serologic marker such as positive RF or ANA
- a small subset of the vasculitides, the small vessel ANCA-associated vasculitides, have a measurable serological component, but even these are often considered a separate entity from seropositive disease by experts



Differential Diagnosis of Elevated ESR

- Systemic inflammatory diseases
- Localized inflammatory diseases
- Malignancy
- Trauma
- Infection
- Tissue injury/ischemia

ESR (and CRP) is insensitive for polymyositis/dermatomyositis, AS, scleroderma, SLE, viral infections

ESR can also be elevated in anemia, end-stage renal disease, females, increased age, obesity



Glucosamine Therapy for Treating Osteoarthritis

Cochrane DB Syst Rev 2009;CD002946

Study: Meta-analysis of 25 RCTs (n=4,963) examining the efficacy of glucosamine on OA.

Results: Collectively the 25 RCTs favored glucosamine over placebo for total reduction in pain with 22% improvement as well as improvement in function using the Lequesne index. However, results were not uniformly positive. Only the glucosamine containing Rotta preparation was found to be significant. Rotta preparation also showed that glucosamine was able to slow radiological evidence of OA over a 3 yr period. Glucosamine had an excellent safety profile.

Conclusion: Rotta preparation of glucosamine was superior to placebo in the treatment of pain and functional impairment resulting from OA.



Intraarticular Corticosteroid for Treatment of Osteoarthritis of the Knee

Cochrane DB Syst Rev 2009;CD005328

Population: Patients with osteoarthritis (OA) of the knee.

Intervention: Intraarticular (IA) corticosteroid injection.

Results: 28 RCTs and quasi-RCTs (n=1,973). IA corticosteroids were more effective than placebo for pain reduction and global assessment at 1 wk post-injection. There was significant pain reduction at 2 and 3 wk, but no benefit for pain and function beyond 4 wk post-injection. There was no benefit for global function beyond 1 wk post-injection. There were higher rates of pain reduction at 4 wk post-injection for triamcinolone hexacetonide vs. betamethasone. There was no difference between IA corticosteroids and joint lavage in outcomes or safety. Hyaluronic acid injections showed better response than IA corticosteroids between 5 and 13 wk post-injection.

Conclusion: IA corticosteroid injection is effective for the short-term treatment of OA of the knee with few side effects. Hyaluronic acid therapy can provide more lasting results.

Table 10. Autoantibodies and their Prevalence in Rheumatic Diseases

Autoantibody	Disease	Healthy Controls	Comments
RF	RA 80% SS 50% SLE 20%	<5% 10-20% >65	Autoantibodies directed against Fc domain of IgG Sensitive in RA (can be negative early in disease course), levels correlate with disease activity Present in most seropositive diseases Non-specific; may be present in IE, TB, hepatitis C, silicosis, sarcoidosis
Anti-CCP	RA 80%		Specific for RA (94-98%) May be useful in early disease and to predict aggressive disease
ANA	SLE 98% MCTD 100% SS 40-70% CREST 60-80%	<5% (seen in other CTDs)	Ab against nuclear components (DNA, RNA, histones, centromere) Sensitive but not specific for SLE Given high false positive rate -only measure when high pre-test probability of CTD
Anti-dsDNA	SLE 50-70%	0%	Specific for SLE (95%) Levels correlate with disease activity
Anti-Sm	SLE <30%	0%	Specific but not sensitive for SLE Does not correlate with SLE disease activity
Anti-Ro (SSA)	SS 40-95% SSc 21% SLE 32% RA 15%	0.5%	Subacute cutaneous SLE (74%) May be only Ab present in ANA negative SLE Increases risk of having child with neonatal lupus syndrome
Anti-La (SSB)	SS 40% SLE 10%	0%	Usually occurs with anti-Ro Specific for SS and SLE when anti-Ro is also positive Increases risk of having child with neonatal lupus syndrome
Antiphospholipid Ab (LAC, ACLA)	APLA 100% SLE 31-40%	<5%	By definition present in APLA Only small subset of SLE patients develop clinical syndrome of APLA If positive, will often get a false positive VDRL test
Anti-Histone	Drug-induced SLE 95% SLE 30-80%	0% 0%	Highly specific for drug-induced SLE
Anti-RNP	MCTD		High titres present in MCTD; present in many other CTD (especially SLE)
Anti-Centromere	CREST >80%	0%	Specific for CREST variant of systemic sclerosis
Anti-Topoisomerase I (formerly Scl-70)	Diffuse SSc 26-76%	0%	Specific for SSc Increased risk pulmonary fibrosis in SSc
c-ANCA	Active GPA >90%	0%	Specific and sensitive
p-ANCA	GPA 10% Other vasculitis	0%	Nonspecific and poor sensitivity (found in ulcerative colitis, PAN, microscopic polyangiitis, Churg-Strauss, rapidly progressive glomerulonephritis)
Anti-Mi-2	DMM 15-20%		Specific but not sensitive (not available in all centres)
Ab Against RBCs, WBCs, or Platelets	SLE		Perform direct Coomb's test Test Hb, reticulocyte, leukocyte and platelet count, antiplatelet Abs

- note: some individuals in the normal population test positive for RF and/or ANA, but do not have the conditions listed in Table 10



OARS Guidelines for the Non-Surgical Management of Knee Osteoarthritis

Osteoarthritis Cartilage 2014;22:363-388

Objective: To develop concise, updated consensus guidelines for the management of knee OA.

Methods: The OA Guidelines Development Group consisted of 13 physicians from relevant medical specialties and a patient representative. Based on previous OA guidelines and a systematic review of the OA literature, 29 treatment modalities were investigated. Treatments were recommended as Appropriate, Uncertain, or Not Appropriate, for each of four clinical sub-phenotypes and accompanied by 1-10 risk and benefit scores.

Results: Appropriate treatment modalities for all individuals with knee OA included biomechanical interventions, IA corticosteroids, exercise, self-management and education, strength training, and weight management. Treatments appropriate for specific clinical sub-phenotypes included acetaminophen, balneotherapy, capsaicin, canes, duloxetine, oral and topical NSAIDs. Treatments of uncertain appropriateness for specific clinical sub-phenotypes included acupuncture, avocado soybean unsaponifiables, chondroitin, crutches, diacerein, glucosamine, IA hyaluronic acid, opioids, roship, transcutaneous electrical nerve stimulation, and U/S. Treatments voted not appropriate included risedronate and neuromuscular electrical stimulation.

Conclusion: Several mainstream treatments are effective for all patients with knee OA, whereas others are only appropriate for certain subtypes. Treatments of uncertain appropriateness can still be considered as treatment and should be based on risk-benefit profile and individual characteristics, as well as comorbidities and preferences of the patient.

Connective Tissue Disorders

Table 11. Features of Seropositive Arthropathies

	RA	SLE	Scleroderma	Dermatomyositis
CLINICAL FEATURES				
History	Symmetrical polyarthritis (small joint involvement) Morning stiffness (> 1 h)	Multisystemic disease: rash, photosensitivity, Raynaud's, alopecia, cardiac and pulmonary serositis, CNS symptoms, glomerulonephritis	Skin tightness, stiffness of fingers, Raynaud's, heartburn, dysphagia, pulmonary HTN, renal crisis with new onset HTN or hypertensive urgency/emergency, dyspnea on exertion	Heliotrope rash (periocular), Gottron's papules (violaceous papules over knuckles and IP joints) ± poikiloderma Shawl sign: macular erythema over chest and shoulder Proximal muscle weakness ± pain Dyspnea on exertion
Physical Examination	Effused joints Tenosynovitis Subcutaneous nodules Joint deformities Bone-on-bone crepitus in advanced disease	Confirm historical findings (rash, serositis, renal, CVS, etc.) ± effused (typically small) joints (can be minimal, look for soft tissue swelling)	Skin tightness on dorsum of hand, facial skin tightening, telangiectasia, calcinosis, non-effused joint, inspiratory crackles	Rash, proximal muscle weakness, inspiratory crackles
LABORATORY				
Non-Specific	↑ ESR in 50-60% ↑ platelets ↓ Hb	↑ ESR ↓ platelets (autoimmune) ↓ Hb (autoimmune) ↓ WBC (leukopenia, lymphopenia)	↑ ESR ↓ Hb Normal WBC	Possible increased ESR ↓ Hb Normal WBC
Specific	RF +ve in ~80% Anti-CCP +ve in ~80%	ANA +ve in 98% Anti-dsDNA +ve in 50-70% Anti-SM +ve in 30% ↓ C3, C4, total hemolytic complement False positive VDRL (in SLE subtypes) ↑ PTT (in SLE subtypes, e.g. APLA)	ANA +ve in >90% Anti-topoisomerase 1 (diffuse) Anti-centromere (usually in CREST, see RH13)	CK elevated in 80% ANA +ve in 33% anti-Jo-1, anti-Mi-2 Muscle biopsy EMG MRI
Radiographs	Periarticular osteopenia Joint space narrowing Erosions Absence of bone repair Symmetric/concentric	Non-erosive ± osteopenia ± soft tissue swelling	± pulmonary fibrosis ± esophageal dysmotility ± calcinosis ± ILD	± esophageal dysmotility ± ILD ± calcifications

Rheumatoid Arthritis

Definition

- chronic, symmetric, erosive synovitis of peripheral joints (e.g. wrists, MCPs, MTPs)
- characterized by a number of extra-articular features

Table 12. 2010 ACR/EULAR Classification Criteria for RA

Criteria	Score	Comments
1. Joint involvement (swollen or tender)		
1 large joint (shoulders, elbows, hips, knees, and ankles)	0	
2-10 large joints	1	
1-3 small joints (MCPs, PIPs, wrists, 2nd-5th MTPs)	2	
4-10 small joints	3	
> 10 joints (at least 1 small joint)	5	
2. Serology		Total score of ≥6: definite RA Must have ≥1 joint with definite clinical swelling, not better explained by other disease
Negative RF and negative Anti-CCP	0	
Low-positive RF or low-positive Anti-CCP (<3x ULN)	2	
High-positive RF or high-positive Anti-CCP (>3x ULN)	3	
3. Acute phase reactants		
Normal CRP and normal ESR	0	
Abnormal CRP and abnormal ESR	1	
4. Duration of symptoms		
<6 wk	0	
≥6 wk	1	

Arthritis Rheum 2010;62:2569-2581



RA is an independent risk factor for atherosclerosis and CV disease. RA is associated with increased overall mortality/morbidity from all causes: CV disease, neoplasm (especially lymphoma), infection



Common Presentation

- Morning stiffness > 1 h, improves with use
- Symmetric joint involvement
- Initially involves small joints of hands and feet
- Constitutional symptoms

Pathophysiology

- autoimmune disorder, unknown etiology
- complex interaction of genes and environment leading to breakdown of immune tolerance: many pathways result in autoreactivity leading to a final common pathway to synovial inflammation
 - genetic predisposition: HLA-DR4/DR1 association (93% of patients have either HLA type), cytokine promoters, T cell signaling
 - epigenetic: DNA hypomethylation, dysregulated histones, microRNA expression
 - environment: repeated activation of innate immunity, cigarette smoking increases susceptibility 20-40 fold
 - ♦ induction of enzymes that convert arginine to citrulline caused by environmental stress (cigarette smoking)
 - ♦ RA: propensity for immune reactivity to neoepitopes created by protein citrullination and production of anti-citrullinated protein antibodies
 - ♦ second-hit required for autoantibody-mediated synovial inflammation: increase in vascular permeability provides access to joint and permits complement fixation, recruitment of immune cells, and inflammation
- once inflammatory process is established, synovium organizes itself into an invasive tissue that degrades cartilage and bone
 - direct invasion of proliferating synovial fibroblast cells into cartilage at the pannus-cartilage junction; inflammatory mediators lead to release of collagenases resulting in destruction of articular cartilage and subchondral bone
 - fibroblast-like synoviocytes in the rheumatoid synovium can migrate from joint to joint (may explain symmetric polyarticular presentation)
- progressive bone destruction with absence of bone repair in response to inflammation
 - TNF increases osteoclasts and decreases osteoblasts at the site of inflammation
 - RANK ligand regulates osteoclast-mediated destruction

Epidemiology

- most common inflammatory arthritis: prevalence 1% of population
- F:M = 3:1
- age of onset 20-40 yr

Signs and Symptoms

- variable course of exacerbations and remissions
- morning stiffness >1 h, improves with use, increases with rest
- polyarthritis: symmetric joint involvement (tender, swollen), small joints affected, most commonly MCP, PIP, MTP
- extra-articular (systemic) symptoms: profound fatigue, depression, myalgia, weight loss
- limitation of function and decrease in global functional status
- complications of chronic synovitis
 - signs of mechanical joint damage: loss of motion, instability, deformity, crepitus, joint deformities
 - ♦ swan neck deformity, boutonniere deformity
 - ♦ ulnar deviation of MCP, radial deviation of wrist joint
 - ♦ hammer toe, mallet toe, claw toe
 - ♦ flexion contractures
 - atlanto-axial and subaxial subluxation
 - ♦ C-spine instability
 - ♦ neurological impingement (long tract signs)
 - ♦ difficult/dangerous intubation: risk of worsening subluxation and damage to spinal cord
 - limited shoulder mobility, spontaneous tears of the rotator cuff leading to chronic spasm
 - tenosynovitis → may cause rupture of tendons
 - carpal tunnel syndrome
 - ruptured Baker's cyst (outpouching of synovium behind the knee); presentation similar to acute DVT

Table 13. Extra-Articular Features of RA Classified by Underlying Pathophysiology

System	Vasculitic	Lymphocytic Infiltrate
Skin	Periungual infarction, cutaneous ulcers, palpable purpura	Rheumatoid nodules (may have vasculitic component)
Ocular	Episcleritis, scleritis	Keratoconjunctivitis sicca
Head and Neck		Xerostomia, Hashimoto's thyroiditis (see Endocrinology , E27)
Cardiac		Peri-/myocarditis, valvular disease, conduction defects
Pulmonary		Pulmonary fibrosis, pleural effusion, pleuritis, pulmonary nodules
Neurologic	Peripheral neuropathy: sensory stocking-glove, mononeuritis multiplex	
Hematologic		Splenomegaly, neutropenia (Felty's syndrome)
Renal		Amyloidosis – caused by accumulation of abnormal proteins

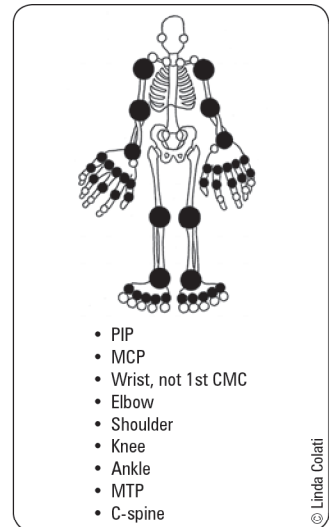


Figure 5. Common sites of joint involvement in RA

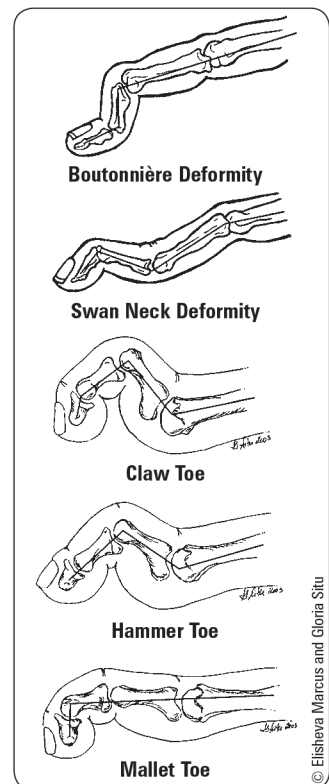


Figure 6. Joint deformities



Syndromes in RA

- SS (common): keratoconjunctivitis sicca and xerostomia (dry eyes and mouth)
- Caplan's syndrome (rare): multiple pulmonary nodules and pneumoconiosis
- Felty's syndrome (rare): arthritis, splenomegaly, neutropenia

Classification of Global Functional Status in RA

- **Class I:** able to perform usual ADLs (self-care, vocational, avocational)
- **Class II:** able to perform self-care and vocational activities, restriction of avocational activities
- **Class III:** able to perform self-care, restriction of vocational and avocational activities
- **Class IV:** limited ability to perform self-care, vocational, and avocational activities

Investigations

- blood work
 - RF: sensitivity 80% but non-specific; may not be present at onset of symptoms; levels correlate with disease activity
 - ♦ can be associated with more erosions, more extra-articular manifestations, and worse function
 - anti-CCP: sensitivity 80% but more specific (94-98%); may precede onset of symptoms
 - increased disease activity is associated with decreased Hb (anemia of chronic disease), increased platelets, ESR, CRP, and RF
- imaging
 - x-rays may be normal at onset
 - first change is periarticular osteopenia, followed by erosions
 - U/S, MRI may be used to image hands to detect early synovitis and erosions

Treatment

- goals of therapy: remission or lowest possible disease activity
 - control disease activity
 - relieve pain and stiffness
 - maintain function and lifestyle
 - prevent or control joint damage
 - key is early diagnosis and early intervention with DMARDs
 - “window of opportunity” = early treatment within first 3 mo of disease may allow better control/remission
- behavioural
 - exercise program (isometrics and active, gentle ROM exercise during flares, aquatic/aerobic/strengthening exercise between flares), assistive devices as needed
 - job modification may be necessary
- pharmacologic: alter disease progression
 - DMARDs
 - ♦ Standard of care and should be started as soon as possible
 - ♦ MTX is the gold standard and is first-line unless contraindicated
 - delayed onset of action (may take 8-12 wks)
 - potential toxicities: GI, hematologic, hepatic, pulmonary, teratogenic
 - if inadequate response (3-6 mo) → combine or switch
 - add-ons include: hydroxychloroquine, sulfasalazine, leflunomide
 - biologics
 - ♦ indicated if inadequate response to DMARDs
 - ♦ can be combined with DMARD therapy
 - ♦ options: infliximab, etanercept, adalimumab, abatacept, rituximab, tocilizumab
 - ♦ reassess every 3-6 mo and monitor disease severity
- pharmacologic: reduce inflammation and pain
 - NSAIDs
 - ♦ individualize according to efficacy and tolerability
 - ♦ contraindicated/cautioned in some patients (e.g. PUD, ischemic cardiac disease, pregnancy)
 - ♦ add acetaminophen ± opioid prn for synergistic pain control
 - corticosteroids
 - ♦ local: injections to control symptoms in a specific joint
 - ♦ systemic (prednisone)
 - low dose (5-10 mg/d) useful for short-term to improve symptoms if NSAIDs ineffective, to bridge gap until DMARDs take effect
 - severe RA: add low dose prednisone to DMARDs
 - do baseline DEXA bone density scan and consider bone supportive pharmacologic therapy if using corticosteroids >3 mo at 7.5mg/d
 - cautions/contraindications: active infection, TB, osteoporosis, HTN, gastric ulcer, DM

Follow-Up Management and Clinical Outcomes

- follow-up every 3-6 mo, then 6-12 mo after inflammation has been suppressed
- examine joints for active inflammation – if active, consider adjusting medications, PT/OT
- if assessment reveals joint damage – consider analgesia, referral to PT/OT, surgical options
- outcome depends on disease activity, joint damage, physical functional status, psychological health, and comorbidities



Poor prognostic features of RA include: young age of onset, high RF titer, elevated ESR, activity of >20 joints, and presence of extra-articular features



Side Effects of Steroids

- Weight gain
- Osteoporosis
- AVN
- Cataracts, glaucoma
- PUD
- Susceptibility to infection
- Easy bruising
- Acne
- HTN
- Hyperlipidemia
- Hypokalemia, hyperglycemia
- Mood swings



Only DMARDs and biologics (not analgesics or NSAIDs) alter the course of RA



Comparison of Treatment Strategies in Early Rheumatoid Arthritis

Ann Intern Med 2007;146:406-415

Study: RCT of 508 patients comparing 4 different treatment strategies for early RA (known as the BEST trial).

Intervention

- Group 1: Sequential Monotherapy with traditional DMARDs
- Group 2: Step-Up Combination Therapy
- Group 3: Initial Combination Therapy with prednisone (high dose)
- Group 4: Initial Combination Therapy with infliximab

Results: Patients in groups 3 and 4 responded faster and had significantly greater overall change in physical function scores after the first year of treatment. By end of the second year, groups 1 and 2 had achieved a similar response to groups 3 and 4. Groups 3 and 4 also showed significantly less radiologic progression of their disease over two years than groups 1 and 2. There were no significant differences in toxicity levels between the 4 groups.

Conclusions: Initial combination therapy with prednisone or infliximab results in faster response rates. Whether faster initial response rates leads to better long-term disease outcomes has not yet been studied.

- functional capacity is a useful tool for determining therapeutic effectiveness: many tools for evaluation have been validated
- patients with RA have an increased prevalence of other serious illnesses: infection (e.g. pulmonary, skin, joint), renal impairment, lymphoproliferative disorders, cardiovascular disease (correlates with disease activity and duration)
- increased risk of premature mortality, decreased life expectancy (most mortality not directly caused by RA)

Surgical Therapy

- indicated for structural joint damage
- surgical options include: synovectomy, joint replacement, joint fusion, reconstruction/tendon repair

Systemic Lupus Erythematosus

- see [Nephrology](#), NP22 and [Dermatology](#), D41

Definition

- chronic inflammatory multi-system disease of unknown etiology
- characterized by production of autoantibodies and diverse clinical manifestations

Table 14. Diagnostic Criteria of SLE*

Criteria	Description
CLINICAL	
Malar rash	Classic "butterfly rash", sparing of nasolabial folds, no scarring
Discoid rash	May cause scarring due to invasion of basement membrane
Photosensitivity	Skin rash in reaction to sunlight
Oral/nasal ulcers	Usually painless
Arthritis	Symmetric, involving ≥ 2 small or large peripheral joints, non-erosive
Serositis	Pleuritis or pericarditis
Neurologic disorder	Seizures or psychosis
LABORATORY	
Renal disorder	Proteinuria (>0.5 g/d or 3+) Cellular casts (RBC, Hb, granular, tubular, mixed)
Hematologic disorder	Hemolytic anemia, leukopenia, lymphopenia, thrombocytopenia
Immunologic disorder	Anti-dsDNA or anti-Sm or antiphospholipid Ab (anticardiolipin Ab, SLE anticoagulant) or false positive VDRL with 6 mo confirmatory negative
ANA	Most sensitive test (98%), not specific

*Note: "4, 7, 11" rule \rightarrow 4 (or more) out of 11 criteria (4 lab, 7 clinical) must be present, serially or simultaneously, for diagnosis American College of Rheumatology, 1997 update

Etiology and Pathophysiology

- production of autoantibodies causing multi-organ inflammation
- multi-factorial etiology
- **genetics**
 - common association with HLA-B8/DR3; $\sim 10\%$ have positive family history
 - strong association with defects in apoptotic clearance \rightarrow fragments of nuclear particles captured by antigen-presenting cells \rightarrow develop anti-nuclear antibodies
 - cytokines involved in inflammatory process and tissue injury: B-lymphocyte stimulator (BlyS), IL-6, IL-17, IL-18, TNF- α
- **environment**
 - UV radiation, cigarette smoking, infection, vitamin D deficiency
- **estrogen**
 - increased incidence after puberty, decreased incidence after menopause
 - men with SLE have higher concentration of estrogenic metabolites
- **infection**
 - viral (non-specific stimulant of immune response)
- **drug-induced**
 - anti-hypertensives (hydralazine), anti-convulsants (phenytoin), anti-arrhythmics (procainamide), isoniazid, biologics, oral contraceptive pills
 - anti-histone Ab are commonly seen in drug-induced SLE
 - symptoms resolve with discontinuation of offending drug



CRA Guidelines for Pharmacological Management of RA with Traditional and Biologic DMARDs
J Rheumatol 2011;39:1559-1582

CRA Recommendations of RA Pharmacologic Management

1. General Management: Remission is the goal of management and if not possible, minimal disease activity and quality of life improvement are desired. Poor prognostic factors should be assessed at baseline (RF, functional limitation, extra-articular features). Active RA patients should be monitored every 1-3 mo. A change in management should be considered where erosions are seen on x-ray despite clinical response.
2. Glucocorticoids: Should be used at the lowest possible dose and tapered as soon as possible. Can be added to initial DMARD therapy or used for managing flares, or symptom control if all other options have been exhausted.
3. Treatment with MTX or DMARD: MTX is the preferred DMARD and should be used unless contraindicated. DMARDs should be used rapidly in patients with persistent synovitis. CBC, LFT, renal function, and CXR should be assessed prior to MTX therapy. MTX requires individualized dosing. In patients with poor prognostic features or high disease activity, DMARD combinations where MTX is the anchor medication should be considered.

Biologics are indicated for therapy in patients who continue to have moderate-high disease activity despite being treated with at least two DMARDs in therapeutic doses for 3 mo. Anti-TNFs are the first line recommended treatment after DMARDs. Addition of MTX to biologics improves efficacy.



Diagnostic Criteria of SLE

MD SOAP BRAIN

Malar rash	Blood
Discoid rash	Renal
Serositis	Arthritis
Oral ulcers	Immune
ANA	Neurologic
Photosensitivity	

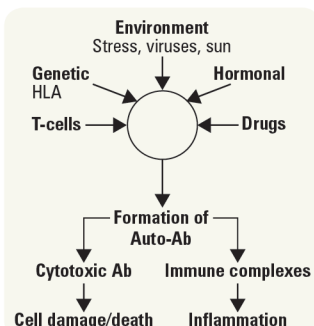


Figure 7. Multi-factorial etiology of SLE

Epidemiology

- prevalence: 0.05% overall
- F:M = 10:1
- age of onset in reproductive yr (13-40)
- more common and severe in African-Americans and Asians
- bimodal mortality pattern
 - early (within 2 yr)
 - ♦ active SLE, active nephritis, infection secondary to steroid use
 - late (>10 yr)
 - ♦ inactive SLE, inactive nephritis, atherosclerosis likely due to chronic inflammation

Signs and Symptoms

- characterized by periods of exacerbation and remission

Table 15. Symptoms of SLE

System	Symptoms
Systemic	Fatigue, malaise, weight loss, fever, lymphadenopathy
Renal	HTN, peripheral edema, glomerulonephritis, renal failure
Dermatologic	Photosensitivity, malar rash, discoid rash, oral ulcers, alopecia (hair loss), purpura, panniculitis (inflammation of subcutaneous fat and muscle tissue), urticaria
Musculoskeletal	Polyarthralgias, polyarthritis, myalgias, AVN; reducible deformities of hand = Jaccoud's arthritis
Ophthalmic	Keratoconjunctivitis sicca, episcleritis, scleritis, cytooid bodies (cotton wool exudates on fundoscopy = infarction of nerve cell layer of retina)
Cardiac	Pericarditis, CAD, non-bacterial endocarditis (Libman-Sachs), myocarditis Note: SLE is an independent risk factor for atherosclerosis and CAD
Vascular	Raynaud's phenomenon, livedo reticularis (mottled discoloration of skin due to narrowing of blood vessels, characteristic lacy or net-like appearance), thrombosis, vasculitis
Respiratory	Pleuritis, ILD, pulmonary HTN, PE, alveolar hemorrhage
Gastrointestinal	Pancreatitis, SLE enteropathy, hepatitis, hepatomegaly, splenomegaly
Neurologic	H/A, depression, psychosis, seizures, cerebritis, transverse myelitis, peripheral neuropathy, stroke
Life/Organ-Threatening	Cardiac: coronary vasculitis, malignant HTN, tamponade Hematologic: hemolytic anemia, neutropenia, thrombocytopenia, TTP, thrombosis Neurologic: seizures, CVA, stroke Respiratory: pulmonary hypertension, pulmonary hemorrhage, emboli

Investigations

- ANA (sensitivity 98%, but poor specificity → used as a screening test, ANA titres are not useful to follow disease course)
- anti-dsDNA and anti-Sm are specific (95-99%)
- anti-dsDNA titer and serum complement (C3, C4) are useful to monitor treatment response in patients who are clinically and serologically concordant
 - anti-dsDNA increases and C3 and C4 decrease with disease activity
- antiphospholipid Ab (anti-cardiolipin Ab and SLE anticoagulant), may cause increased risk of clotting and increased aPTT

Treatment

- **goals of therapy**
 - treat early and avoid long-term steroid use, if unavoidable see [Endocrinology](#), E42 for osteoporosis management
 - if high doses of steroids necessary for long-term control, add steroid-sparing agents and taper when possible
 - treatment is tailored to organ system involved and severity of disease
 - all medications used to treat SLE require periodic monitoring for potential toxicity
- **dermatologic**
 - sunscreen, avoid UV light and estrogens
 - topical steroids, hydroxychloroquine
- **musculoskeletal**
 - NSAIDs ± gastroprotective agent for arthritis (also beneficial for pleuritis and pericarditis)
 - hydroxychloroquine improves long-term control and prevents flares
 - bisphosphonates, calcium, vitamin D to combat osteoporosis
- **organ-threatening disease**
 - high-dose oral prednisone or IV methylprednisolone in severe disease
 - steroid-sparing agents: azathioprine, MTX, mycophenolate mofetil
 - IV cyclophosphamide for serious organ involvement (e.g. cerebritis or lupus nephritis) see [Nephrology](#), NP22 for clinical features of lupus nephritis



Radiographically, the arthritis of SLE is non-erosive (unlike RA)



Consider SLE in a patient who has involvement of 2 or more organ systems



Drug-Induced SLE
Often presents atypically with systemic features and serositis; usually associated with anti-histone Ab



Raynaud's Phenomenon
Vasospastic disorder characteristically causing discoloration of fingers and toes (white → blue → red).
Classic triggers: cold and emotional stress



Antiphospholipid Antibody Syndrome



Definition

- multi-system vasculopathy manifested by recurrent thromboembolic events, spontaneous abortions, and thrombocytopenia
- often presents with migraine-type H/As
- circulating antiphospholipid autoantibodies interfere with coagulation cascade
- **primary APLA**: occurs in the absence of other disease
- **secondary APLA**: occurs in the setting of a connective tissue disease (including SLE), malignancy, drugs (hydralazine, procainamide, phenytoin, interferon, quinidine), and infections (HIV, TB, hepatitis C, infectious mononucleosis)
- **catastrophic APLA**: development within 1 wk of small vessel thrombotic occlusion in ≥ 3 organ systems with positive antiphospholipid Ab (high mortality)

Table 16. Classification Criteria of APLA*

Criteria	Description
CLINICAL	
Vascular thrombosis	Arterial: stroke/TIA, multi-infarct dementia, MI, valvular incompetence, limb ischemia Venous: DVT, PE, renal and retinal vein thrombosis Must be confirmed by imaging or histopathology
Pregnancy morbidity	Fetal death (> 10 wk GA), recurrent spontaneous abortions (< 10 wk GA) or premature birth (< 34 wk GA)
LABORATORY	
Labs must be positive on 2 occasions, at least 12 wk apart	
SLE anticoagulant	
Anti-cardiolipin Ab	IgG and/or IgM
Anti- β_2 glycoprotein-I Ab	IgG and/or IgM

* 1 clinical and 1 laboratory criteria must be present
J Thromb Haemost 2006;4:295-306



Manifestations of APLA

- Thromboembolic events
- Spontaneous abortions
- Thrombocytopenia
- Associated with livedo reticularis, migraine headaches

Signs and Symptoms

- see clinical criteria in Table 16
- hematologic
 - thrombocytopenia, hemolytic anemia, neutropenia
- dermatologic
 - livedo reticularis, Raynaud's phenomenon, purpura, leg ulcers, and gangrene



Arterial and venous thrombosis are usually mutually exclusive

Treatment

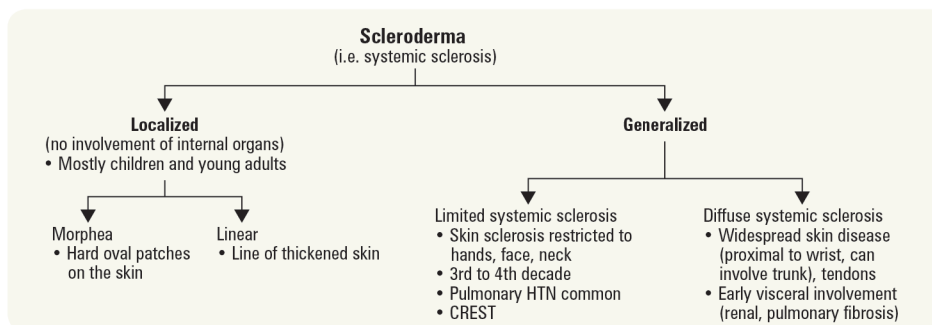
- thrombosis
 - lifelong anti-coagulation with warfarin
 - target INR 2.0-3.0 for first venous event, > 3.0 for recurrent and/or arterial event
- recurrent fetal loss
 - heparin/low molecular weight heparin \pm ASA during pregnancy
- catastrophic APLA
 - high-dose steroids, anti-coagulation, cyclophosphamide, plasmapheresis

Scleroderma (i.e. Systemic Sclerosis)



Definition

- a non-inflammatory autoimmune disorder characterized by widespread small vessel vasculopathy, production of autoantibodies, and fibroblast dysfunction causing fibrosis



CREST Syndrome

Calcinosis
Raynaud's phenomenon
Esophageal dysmotility
Sclerodactyly
Telangiectasia

Figure 8. Forms of scleroderma

Table 17. The American College of Rheumatology (ACR)/European League Against Rheumatism (EULAR) Criteria for Scleroderma*

Item	Sub-item	Score
1. Skin thickening of fingers of both hands extending proximal to the MTPs (sufficient criterion)		9
2. Skin thickening of the fingers	Puffy fingers	2
	Sclerodactyly	4
3. Fingertip lesions	Digital tip ulcers	2
	Fingertip pitting scars	3
4. Telangiectasia		2
5. Abnormal nailfold capillaries		2
6. Pulmonary arterial HTN ± ILD (max score 2)	Pulmonary arterial HTN	2
	ILD	2
7. Raynaud's phenomenon		3
8. Scleroderma related Ab	Anticentromere	3
	Anti-topoisomerase I	
	Anti-RNA polymerase III	

* Score of ≥9 is sufficient to classify a patient as having definite scleroderma (sensitivity 0.95, specificity 0.93)
Arthritis & Rheum 2013;65(11):2737-2747

Etiology and Pathophysiology

- idiopathic vasculopathy (not vasculitis) leading to atrophy and fibrosis of tissues
 - intimal proliferation and media mucinous degeneration → progressive obliteration of vessel lumen → fibrotic tissue
 - resembles malignant HTN

Epidemiology

- F:M = 3-4:1, peaking in 5th and 6th decades
- associated with HLA-DR1
- associated with environmental exposure (silica, epoxy resins, toxic oil, aromatic hydrocarbons, polyvinyl chloride)
- limited systemic sclerosis has a higher survival prognosis (>70% at 10 yr) than diffuse systemic sclerosis (40-60% at 10 yr)

Signs and Symptoms

Table 18. Clinical Manifestations of Scleroderma

System	Features
Dermatologic	Painless non-pitting edema → skin tightening Ulcerations, calcinosis, periungual erythema, hypo/hyperpigmentation, pruritus, telangiectasias Characteristic face: mask-like facies with tight lips, beak nose, radial perioral furrows
Vascular	Raynaud's phenomenon → digital pits, gangrene
Gastrointestinal (~90%)	Distal esophageal hypomotility → dysphagia Loss of lower esophageal sphincter function → GERD, ulcerations, strictures Small bowel hypomotility → bacterial overgrowth, diarrhea, bloating, cramps, malabsorption, weight loss Large bowel hypomotility → wide mouth diverticuli are pathognomonic radiographic finding on barium study
Renal	Mild proteinuria, Cr elevation, HTN "Scleroderma renal crisis" (10-15%) may lead to malignant arterial HTN, oliguria, and microangiopathic hemolytic anemia
Pulmonary	Interstitial fibrosis, pulmonary HTN, pleurisy, pleural effusions
Cardiac	Left ventricular dysfunction, pericarditis, pericardial effusion, arrhythmias
Musculoskeletal	Polyarthralgias "Resorption of distal tufts" (radiological finding) Proximal weakness 2° to disuse, atrophy, low grade myopathy
Endocrine	Hypothyroidism

Investigations

- blood work
 - CBC, Cr, ANA
 - anti-topoisomerase I/anti-Scl-70: specific but not sensitive for diffuse systemic sclerosis
 - anti-centromere: favours diagnosis of CREST (limited systemic sclerosis)
- PFT
 - assess for interstitial lung disease
- imaging
 - CXR for fibrosis, echo for pulmonary HTN



Scleroderma is the most common cause of secondary Raynaud's phenomenon



Lung disease is the most common cause of morbidity and mortality



Raynaud's Phenomenon Ddx

COLD HAND

Cryoglobulins/Cryofibrinogens
Obstruction/Occupational
Lupus erythematosus, other connective tissue disease
Diabetes mellitus/Drugs
Hematologic problems (polycythemia, leukemia, etc.)
Arterial problems (atherosclerosis)/
Anorexia nervosa
Neurologic problems (vascular tone)
Disease of unknown origin (idiopathic)



Features of Pathologic Raynaud's Syndrome

- New onset
- Asymmetric
- Precipitated by stimuli other than cold or emotion
- Associated with distal pulp pitting or tissue reabsorption
- Digit ischemia
- Capillary dilatation by capillaroscopy

Treatment

- dermatologic
 - good skin hygiene
 - low-dose prednisone (>20 mg may provoke renal crisis if susceptible), MTX (limited evidence)
- vascular
 - patient education on cold avoidance
 - vasodilators (CCBs, local nitroglycerine cream, systemic PGE₂ inhibitors, PDE5 inhibitors)
- gastrointestinal
 - GERD: PPIs are first line, then H₂-receptor agonists
 - small bowel bacterial overgrowth: broad spectrum antibiotics (tetracycline, metronidazole)
- renal disease
 - ACEI for hypertensive crisis
 - see [Nephrology](#), NP31 for scleroderma renal crisis
- pulmonary
 - early interstitial disease: cyclophosphamide
 - pulmonary HTN: vasodilators e.g. bosentan (Tracleer®), epoprostenol (Flolan®), PDE5 inhibitors
- cardiac
 - pericarditis: systemic steroids
- musculoskeletal
 - arthritis: NSAIDs
 - myositis: systemic steroids



Idiopathic Inflammatory Myopathy

**Definition**

- autoimmune diseases characterized by proximal muscle weakness ± pain
- muscle becomes damaged by a non-suppurative lymphocytic inflammatory process

Classification

- PM/DMM
- adult and juvenile form
- associated with malignancy
 - increased risk of malignancy: age >50, DMM>PM, normal CK, refractory disease
 - 2.4-6.5 fold increased risk of underlying malignancy usually in internal organs
- associated with other connective tissue disease, Raynaud's phenomenon, autoimmune disorders

Inclusion Body Myositis

- age >50, M>F, slowly progressive, vacuoles in cells on biopsy
- suspect when patient unresponsive to treatment
- distal as well as proximal muscle weakness
- muscle biopsy positive for inclusion bodies

**POLYMYOSITIS/DERMATOMYOSITIS****Table 19. Classification Criteria for PM/DMM***

Criteria	Description
1. Symmetric proximal muscle weakness	Typical involvement of shoulder girdle and hip girdle
2. Elevated muscle enzymes	↑ CK, aldolase, LDH, AST, ALT
3. EMG changes	Short polyphasic motor units, high frequency repetitive discharge, insertional irritability
4. Muscle biopsy	Segmental fibre necrosis, basophilic regeneration, perivascular inflammation (DMM), endomyosial inflammation (PM) and atrophy
5. Typical rash of dermatomyositis	Required for diagnosis of DMM (see below)

*Definite if 4 present, probable if 3 present *NEJM* 1975;292:403-407

**Malignancies Associated with DMM**

- Breast
- Lung
- Colon
- Ovarian

Etiology and Pathophysiology

- PM is CD8 cell-mediated muscle necrosis, found in adults
- DMM is B-cell and CD4 immune complex-mediated peri-fascicular vascular abnormalities

Signs and Symptoms

- progressive symmetrical proximal muscle weakness (shoulder and hip) developing over weeks to months
 - difficulty lifting head off pillow, arising from chair, climbing stairs
- dermatological
 - DMM has characteristic dermatological features (F>M, children and adults)
 - ◆ Gottron's papules
 - pink-violaceous, flat-topped papules overlying the dorsal surface of the interphalangeal joints

**Signs of DMM**

Gottron's papules and Gottron's sign are pathognomonic of DMM (occur in 70% of patients)

- ♦ Gottron's sign
 - erythematous, smooth or scaly patches over the dorsal IPs, MCPs, elbows, knees, or medial malleoli
- ♦ heliotrope rash: violaceous rash over the eyelids; usually with edema
- ♦ shawl sign: poikilodermatous erythematous rash over neck, upper chest, and shoulders
- ♦ mechanic's hands: dark, dry, thick scale on palmar and lateral surface of digits
- ♦ periungual erythema
- cardiac
 - arrhythmias, CHF, conduction defect, ventricular hypertrophy, pericarditis
- gastrointestinal
 - oropharyngeal and lower esophageal dysphagia, reflux
- pulmonary
 - weakness of respiratory muscles, ILD, aspiration pneumonia

Investigations

- blood work: CK, ANA, anti-Jo-1 (DMM), anti-Mi-2, anti-SRP
- imaging: MRI may be used to localize biopsy site
- EMG, muscle biopsy

Treatment

- non-pharmacological treatment
 - physical therapy and occupational therapy
- pharmacological treatment
 - high-dose corticosteroid (1-2 mg/kg/d) and slow taper
 - add immunosuppressive agents (azathioprine, MTX, cyclosporine)
 - IVIg if severe or refractory
 - hydroxychloroquine for DMM rash
- malignancy surveillance
 - detailed history and physical (breast, pelvic, and rectal exam)
 - CXR, abdominal and pelvic U/S, fecal occult blood, Pap test, mammogram ± CT scan (thoracic, abdominal, pelvic)

Sjögren's Syndrome

Definition

- autoimmune condition characterized by dry eyes (keratoconjunctivitis sicca/xerophthalmia) and dry mouth (xerostomia), caused by lymphocytic infiltration of salivary and lacrimal glands
- may evolve into systemic disorder with diminished exocrine gland activity in respiratory tract and skin
- primary and secondary form (associated with RA, SLE, DMM, and HIV)
- incidence estimated at 4/100,000 people
- 90% of cases are among females
- mean age of diagnosis is 40-60 yr



Patients with Sjögren's syndrome are at higher risk of non-Hodgkin's lymphoma

Table 20. American College of Rheumatology Classification for Sjögren's*

Criteria	Comments
1. Positive serum anti-SSA/Ro and/or anti-SSB/La or positive RF and ANA titer > 1:320	
2. Labial salivary gland biopsy with focal lymphocytic sialadenitis with focus score ≥ 1 focus $4/\text{mm}^2$	Focus scores are histopathologic grading systems Strongly associated with phenotypic ocular and serological component's of Sjögren's
3. Keratoconjunctivitis sicca with ocular staining score > 3	Ocular staining score based on fluorescein dye examination of conjunctiva and cornea to determine clinical changes

*Classification criteria is met in patients with signs/symptoms of Sjögren's, who have at least 2 of the above features

1. *Arthritis Care & Research* 2012;64(4):475-487; 2. *Arthritis Rheum* 2011;63(7):2021-2030; 3. *Am J Ophthalmol* 2010;149(3):405-441

Signs and Symptoms

- "sicca complex": dry eyes (keratoconjunctivitis sicca/xerophthalmia), dry mouth (xerostomia)
- staphylococcal blepharitis
- dental caries, oral candidiasis, angular cheilitis (inflammation and fissuring at the labial commissures of the mouth)
- systemic complications
 - sinusitis
 - autoimmune thyroid dysfunction
 - arthralgias, arthritis
 - subclinical diffuse ILD, xerotrachea leading to chronic dry cough
 - renal disease, glomerulonephritis
 - palpable purpura, vasculitis
 - peripheral neuropathy
 - lymphoma risk greatly increased

Treatment

- ocular
 - artificial tears or surgical punctal occlusion for dry eyes



Classic Triad (identifies 93% of Sjögren's patients)

- Dry eyes
- Dry mouth (xerostomia) → dysphagia
- Arthritis (small joint, asymmetrical, non-erosive) but may be associated with rheumatoid arthritis, in which case, the arthritis is erosive and symmetric

- oral
 - good dental hygiene, hydration
 - parasympathomimetic agents that stimulate salivary flow (e.g. pilocarpine)
 - topical nystatin or clotrimazole x 4-6 wk for oral candidiasis
- systemic
 - e.g. hydroxychloroquine, corticosteroids

Mixed Connective Tissue Disease

- syndrome with features of 3 different connective tissue diseases (e.g. SLE, scleroderma, PM)
- common symptoms: Raynaud's phenomenon, swollen fingers
- blood work: anti-RNP (see Table 10)
- treatment is generally guided by the severity of symptoms and organ system involvement
- prognosis
 - 50-60% will evolve into SLE
 - 40% will evolve into scleroderma
 - only 10% will remain as MCTD for the rest of their lives
 - cardiac involvement (arrhythmia) common, renal or lung involvement rare

Overlap Syndrome

- syndrome with sufficient diagnostic features of 2+ different connective tissue diseases



Vasculitides

- inflammation and subsequent necrosis of blood vessels leading to tissue ischemia or infarction
- any organ system can be involved
- keys to diagnosis
 - clinical suspicion: suspect in cases of unexplained multiple organ ischemia or systemic illness with no evidence of malignancy or infection
 - labs non-specific: anemia, increased WBC and ESR, abnormal U/A
 - biopsy if tissue accessible
 - angiography if tissue inaccessible
- treatment generally involves corticosteroids and/or immunosuppressive agents

Table 21. Classification of Vasculitis and Characteristic Features

Classification	Characteristic Features
SMALL VESSEL	
<ul style="list-style-type: none"> • Non-ANCA-associated 	Immune complex-mediated (most common mechanism)
Predominantly cutaneous vasculitis	Also known as hypersensitivity/leukocytoclastic vasculitis
Henoch-Schönlein purpura (see Pediatrics , P94)	Vascular deposition of IgA causing systemic vasculitis (skin, GI, renal), usually self-limiting; most common in childhood
Essential cryoglobulinemic vasculitis	Systemic vasculitis caused by circulating cryoproteins forming immune complexes; may be associated with underlying infection (e.g. hepatitis C) or connective tissue disease
<ul style="list-style-type: none"> • ANCA-associated 	
Granulomatosis with polyangiitis (GPA, formerly Wegener's) pR3 (c-ANCA) > MPO (p-ANCA)	Granulomatous inflammation of vessels of respiratory tract and kidneys, initially have URTI symptoms; most common in middle age
Eosinophilic granulomatosis with polyangiitis (Churg-Strauss syndrome) (50% ANCA positive)	Granulomatous inflammation of vessels with hypereosinophilia and eosinophilic tissue infiltration, frequent lung involvement (asthma, allergic rhinitis), can be associated with MPO or pR3, other manifestations include coronary arteritis, myocarditis and neuropathy, average age 40s
Microangiopathic polyangiitis (70% ANCA positive, usually MPO)	Pauci-immune necrotizing vasculitis, affecting kidneys (necrotizing glomerulonephritis), lungs (capillaritis and alveolar hemorrhage), skin, most common in middle age
MEDIUM VESSEL	
Polyarteritis nodosa	Segmental, non-granulomatous necrotizing inflammation Unknown etiology in most cases, any age (average 40-50s), M>F
Kawasaki disease (see Pediatrics , P94)	Arteritis and mucocutaneous lymph node syndrome



Features of Small Vessel Vasculitis

- Palpable purpura
- Vesicles
- Chronic urticaria
- Superficial ulcers



c-ANCA: circulating anti-neutrophil cytoplasmic Ab associated with anti-pR3

p-ANCA: perinuclear anti-neutrophil cytoplasmic Ab associated with multiple antigens, e.g. lactoferrin (IBD), myeloperoxidase (microscopic polyangiitis)



Features of Medium Vessel Vasculitis

- Livedo reticularis
- Erythema nodosum
- Raynaud's phenomenon
- Nodules
- Digital infarcts
- Ulcers

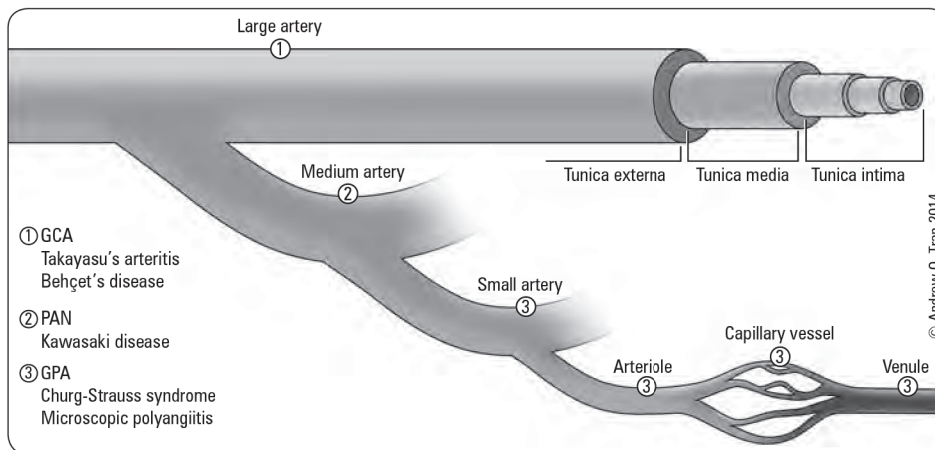


Table 21. Classification of Vasculitis and Characteristic Features (continued)

Classification	Characteristic Features
LARGE VESSEL	
GCA/Temporal arteritis	Inflammation predominantly of the aorta and its branches >50 yr of age, F>M
Takayasu's arteritis	"Pulseless disease", unequal peripheral pulses, chronic inflammation, most often the aorta and its branches Usually young adults of Asian descent, F>M; risk of aortic aneurysm
OTHER VASCULITIDES	
Buerger's disease ("Thromboangiitis Obliterans")	Inflammation secondary to pathological clotting, affects small and medium-sized vessels of distal extremities, may lead to distal claudication and gangrene, most important etiologic factor is cigarette smoking Most common in young Asian males
Behçet's disease	Leukocytoclastic vasculitis, multi-system disorder presenting with ocular involvement (uveitis), recurrent oral and genital ulceration, venous thrombosis, skin and joint involvement, more common in Mediterranean and Asia, average age 30 yr old, M>F
Vasculitis mimicry (i.e. pseudovasculitis)	Cholesterol emboli, atrial myxoma

**Churg-Strauss Triad**

- Allergic rhinitis and asthma (often quiescent at time of vasculitis)
- Eosinophilic infiltrative disease resembling pneumonia
- Systemic vasculitis often mononeuritis multiplex/peripheral neuropathy and peripheral eosinophilia

**Figure 9. Classification of vasculitides by vessel size**

Small Vessel Non-ANCA Associated Vasculitis

CUTANEOUS VASCULITIS

- subdivided into
 - drug-induced vasculitis
 - serum sickness reaction
 - vasculitis associated with other underlying primary diseases

Etiology and Pathophysiology

- cutaneous vasculitis following
 - drug exposure (allopurinol, gold, sulfonamides, penicillin, phenytoin)
 - viral or bacterial infection
 - idiopathic causes
- small vessels involved (post-capillary venules most frequently)
- usually causes a leukocytoclastic vasculitis: debris from neutrophils around vessels
- sometimes due to cryoglobulins which precipitate in cold temperatures

Signs and Symptoms

- palpable purpura ± vesicles and ulceration, urticaria, macules, papules, bullae, subcutaneous nodules
 - renal or joint involvement may occur, especially in children

Investigations

- vascular involvement (both arteriole and venule) established by skin biopsy

Treatment

- stop possible offending drug
- corticosteroids ± immunosuppressive agents
- usually self-limiting

Small Vessel ANCA-Associated Vasculitis

GRANULOMATOSIS WITH POLYANGIITIS (GPA, formerly known as Wegener's Granulomatosis)

Definition

- granulomatous inflammation of vessels that may affect the upper airways (rhinitis, sinusitis), lungs (pulmonary nodules, infiltrates), and kidneys (glomerulonephritis, renal failure)
- highly associated with c-ANCA
- incidence 5 per 100,000; more common in Northern latitudes

Table 22. Classification Criteria for GPA*

Criteria	Description
1. Nasal or oral involvement	Inflammation, ulcers, epistaxis
2. Abnormal findings on CXR	Nodules, cavitations, etc.
3. Urinary sediment	Microscopic hematuria ± RBC casts
4. Biopsy of involved tissue	Lungs show granulomas, kidneys show necrotizing segmental glomerulonephritis

*Diagnosed if 2 or more of the above 4 criteria present American College of Rheumatology, 1990

Etiology

- pathogenesis depends on genetic susceptibility and environmental triggers (e.g. infection)
 - dysregulated immune response due to loss of B and T-cell tolerance
 - acute vascular injury mediated by neutrophils and monocytes

Signs and Symptoms

- systemic
 - malaise, fever, weakness, weight loss
- HEENT
 - sinusitis or rhinitis, nasal crusting and bloody nasal discharge, nasoseptal perforation, saddle nose deformity
 - proptosis due to: inflammation/vasculitis involving extra-ocular muscles, granulomatous retrobulbar space occupying lesions or direct extension of masses from the upper respiratory tract
 - hearing loss due to involvement of CN VIII
- pulmonary
 - cough, hemoptysis, granulomatous upper respiratory tract masses
- renal
 - hematuria
- other
 - joint, skin, eye complaints, vasculitic neuropathy

Investigations

- blood work: anemia (normal MCV), increased WBC, increased Cr, increased ESR, elevated platelet count, ANCA (PR3 > MPO)
- urinalysis: proteinuria, hematuria, RBC casts
- CXR: pneumonitis, lung nodules, infiltrations, cavitory lesions
- biopsy: renal (segmental necrotizing glomerulonephritis), lung (granulomas, tracheobronchial erosion)
- c-ANCA and ESR often correlate with disease activity and used to monitor response to treatment in some patients

Treatment

- prednisone 1 mg/kg/d PO ± cyclophosphamide 2 mg/kg/d PO for 3-6 mo followed by high dose MTX (20-25 mg PO/SC weekly) or azathioprine (2 mg/kg/d PO OD)
- consider biologic agents (rituximab, IVIg) and plasmapheresis (PEXIVAS trial)



Classic Features of GPA

- Necrotizing granulomatous vasculitis of lower and upper respiratory tract
- Focal segmental glomerulonephritis



RAVE Trial

NEJM 2010;363:221-232
Rituximab equivalent or superior to cyclophosphamide in severe or relapsing disease

Medium Vessel Vasculitis

POLYARTERITIS NODOSA

Definition

- systemic, necrotizing vasculitis of medium sized vessels
- ANCA negative
- 30% associated with hepatitis B positivity
- incidence 0.7 per 100,000; affects individuals between 40-60 yr; M:F = 2:1



There is an association between hepatitis B surface antigen (HBsAg) positivity and PAN

Table 23. Classification Criteria for PAN*

Criteria	Description
1. Weight loss	>4 kg, not due to dieting or other factors
2. Myalgias, weakness, or leg tenderness	Diffuse myalgias or weakness
3. Livedo reticularis	Mottled, reticular pattern over skin
4. Neuropathy	Mononeuropathy, mononeuropathy multiplex, or polyneuropathy
5. Testicular pain or tenderness	Not due to infection, trauma, or other causes
6. dBP >90 mmHg	Development of HTN with dBP >90 mmHg
7. Elevated Cr or BUN	Cr > 130 µmol/L (1.5 mg/dL), BUN > 14.3 mmol/L (40 mg/dL)
8. Hepatitis B positive	Presence of hepatitis B surface antigen or Ab
9. Arteriographic abnormality	Commonly aneurysms
10. Biopsy of artery	Presence of granulocytes and/or mononuclear leukocytes in the artery wall

*Diagnosed if 3 or more of the above 10 criteria present American College of Rheumatology, 1990

Etiology and Pathophysiology

- focal panmural necrotizing inflammatory lesions in small and medium-sized arteries
- thrombosis, aneurysm, or dilatation at lesion site may occur
- healed lesions show proliferation of fibrous tissue and endothelial cells that may lead to luminal occlusion

Investigations

- blood work: CBC, ESR, Cr, BUN, p-ANCA, hepatitis B serology
- imaging: angiography
- arterial biopsy

Treatment

- prednisone 1 mg/kg/d PO and cyclophosphamide 2 mg/kg/d PO
- ± anti-viral therapy to enhance clearance of hepatitis B virus

Large Vessel Vasculitis

- see [Ophthalmology](#), OP38

GCA/TEMPORAL ARTERITIS

Table 24. Classification Criteria for GCA*

Criteria	Description
1. Age at onset ≥50	
2. New H/A	Often temporal
3. Temporal artery abnormality	Temporal artery tenderness or decreased pulsations, not due to arteriosclerosis
4. Elevated ESR	ESR ≥50 mm/h
5. Abnormal artery biopsy	Mononuclear cell infiltration or granulomatous inflammation, usually with multinucleated giant cells

*Diagnosed if 3 or more of the above 5 criteria present American College of Rheumatology, 1990

Epidemiology

- most frequent vasculitis in North America
- patients >50 yr
- F:M = 2:1
- North-South gradient (predominance in Northern Europe/US)
- affects extracranial arteries

Signs and Symptoms

- new onset temporal H/A ± scalp tenderness due to inflammation of involved portion of the temporal or occipital arteries
- sudden, painless loss of vision and/or diplopia due to narrowing of the ophthalmic or posterior ciliary arteries (PCA more common); can affect both eyes
- tongue and jaw claudication (pain in muscles of mastication on prolonged chewing)
- PMR (proximal myalgia, constitutional symptoms, elevated ESR) occurs in 30% of patients
- aortic arch syndrome (involvement of subclavian and brachial branches of aorta resulting in pulseless disease), aortic aneurysm ± rupture are late complications



Consider PAN in a non-diabetic patient with mononeuritis multiplex



GCA Criteria
Presence of 3 or more criteria yields sensitivity of 94%, specificity of 91%



Medical Emergency
Untreated, GCA can lead to permanent blindness in 20-25% of patients
Treat on clinical suspicion

Investigations

- diagnosis made by clinical suspicion, increased ESR, increased CRP, temporal artery biopsy within 14 d of starting steroids, possible U/S

Treatment

- if suspect GCA, immediately start high dose prednisone 1 mg/kg in divided doses for approximately 4 wk, and then tapering prednisone as symptoms resolve; highly effective in treatment and in prevention of blindness and other vascular complications
- consider low dose ASA

Prognosis

- increased risk of thoracic aortic aneurysm and aortic dissection
- yearly CXR ± abdominal U/S as screening

Seronegative Rheumatic Disease

Table 25. A Comparison of the Spondyloarthropathies*

Feature	AS	PsA	ReA	EA
M:F	3:1	1:1	8:1	1:1
Age of Onset	20s	35-45	20s	Any
Peripheral Arthritis	25%	96%	90%	Common
Distribution	Axial, LE	Any	LE	LE
Sacroiliitis	100%	40%	80%	20%
Dactylitis	Uncommon	Common	Occasional	Uncommon
Enthesitis	Common	Common	Common	Less Common
Skin Lesions	Rare	100% Psoriasis eventually 70% at onset of arthritis	Common Keratoderma	Occasional Pyoderma, erythema nodosum
Uveitis	Common	Occasional	20%	Rare
Urethritis	Rare	Uncommon	Common	Rare
HLA-B27	90-95%	40%	80%	30%

LE = lower extremities

*Spondyloarthropathy: inflammatory joint disease of the vertebral column

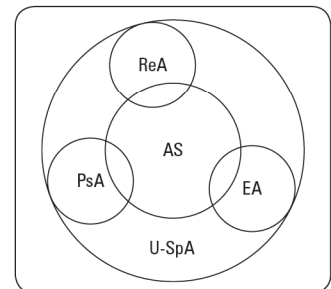


Figure 10. Spondyloarthropathy subsets



Enthesitis: inflammation of tendon or ligament at site of attachment to bone



Consider AS in the differential for causes of aortic regurgitation

Ankylosing Spondylitis

Definition

- chronic inflammatory arthritis involving the sacroiliac joints and vertebrae
- enthesitis is a major feature
- prototypical spondyloarthropathy

Table 26. ASAS Classification Criteria for Axial Spondyloarthritis*

Sacroiliitis on Imaging plus ≥1 AS Feature or HLA-B27 Positive plus ≥2 AS Features	
AS Features <ul style="list-style-type: none"> • HLA-B27 positive • Inflammatory back pain • Arthritis • Enthesitis (heel) • Uveitis • Dactylitis • Psoriasis • Crohn's disease/colitis • Good response to NSAIDs • Family history of AS • Elevated CRP 	Sacroiliitis on Imaging <ul style="list-style-type: none"> • Active (acute) inflammation on MRI highly suggestive of sacroiliitis associated with AS • Definite radiographic sacroiliitis ≥ grade 2 bilaterally or grade 3-4 unilaterally

*For patients with ≥3 mo back pain and age at onset <45 yr

Etiology and Pathophysiology

- inflammation → osteopenia → erosion → ossification → osteoproliferation (syndesmophytes)



Rule of 2s
AS occurs in
 0.2% of the general population
 2% of HLA-B27 positive individuals
 20% of HLA-B27 positive individuals with affected family member

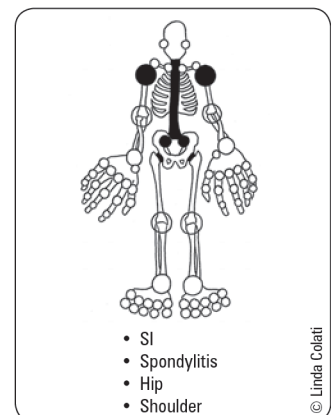


Figure 11. Common sites of involvement of AS

© Linda Colati

Epidemiology

- M:F = 3:1; females have milder disease which may be under-recognized and more peripheral arthritis and upper spine spondylitis
- 90-95% of patients have HLA-B27 (9% HLA-B27 positive in general population)

Table 27. Types of Back Pain

Parameter	Mechanical	Inflammatory
Past History	±	++
Family History	-	+
Onset	Acute	Insidious
Age	15-90 yr	<40 yr
Sleep Disturbance	±	++ (worse during 2nd half of night)
Morning Stiffness	<30 min	>1 h
Involvement of Other Systems	-	+
Exercise	Worse	Better
Rest	Better	Worse
Radiation of Pain	Anatomic (L5-S1)	Diffuse (thoracic, buttock)
Sensory Symptoms	+	-
Motor Symptoms	+	-

Signs and Symptoms

- axial
 - mid and lower back stiffness, prolonged morning stiffness, night pain, persistent buttock pain, painful sacroiliac joint (+ FABER test)
 - spinal restriction (decreased ROM): lumbar (decreased Schöber), thoracic (decreased chest wall expansion, normal >5 cm at T4), cervical (global decrease, often extension first)
 - postural changes: decreased lumbar lordosis + increased thoracic kyphosis + increased cervical flexion = increased occiput to wall distance (>5 cm)
- peripheral
 - asymmetrical large joint arthritis, most often involving lower limb
 - enthesitis: tenderness over tibial tuberosity, or Achilles tendon and plantar fascia insertions into the calcaneus
- extra-articular manifestations
 - ophthalmic: acute anterior uveitis is common (25-30% patients)
 - renal: amyloidosis (late and rare), IgA nephropathy
 - gastrointestinal: IBD
 - cardiac: aortitis, aortic regurgitation, pericarditis, conduction disturbances, heart failure (rare)
 - respiratory: apical fibrosis (rare)
 - neurologic: cauda equina syndrome (rare)
 - skin: psoriasis

Investigations

- x-ray of SI joint: "pseudowidening" of joint due to erosion with joint sclerosis → bony fusion (late), symmetric sacroiliitis
- x-ray of spine: "squaring of edges" from erosion and sclerosis on corners of vertebral bodies (shiny corner sign) leading to ossification of outer fibres of annulus fibrosus (bridging syndesmophytes) → "bamboo spine" radiographically
- MRI of spine: assess activity in early disease; detection of cartilage changes, bone marrow edema, bone erosions, and subchondral bone changes. Best seen on T2 STIR (short tau inversion recovery) images (suppress fat and see bone edema)

Treatment

- non-pharmacological therapy
 - prevent fusion from poor posture and disability through: exercise (e.g. swimming), postural and deep breathing exercises, outpatient PT, smoking cessation
- pharmacological therapy
 - NSAIDs (first line of treatment)
 - glucocorticoids (topical eye drops, local injections)
 - DMARDs for peripheral arthritis (sulfasalazine, MTX)
 - biologics for axial and peripheral involvement
 - manage extra-articular manifestations
- surgical therapy
 - hip replacement, vertebral osteotomy for marked deformity

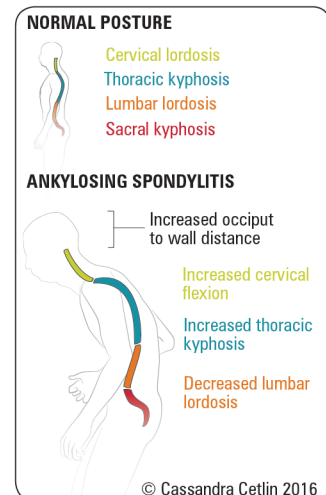


Figure 12. AS Postural Changes



The **Bath Ankylosing Spondylitis Disease Activity Index (BASDAI)** is a self-reported scoring system that focuses on fatigue, axial pain, peripheral pain, enthesitis, and morning stiffness



FABER (Flexion, Abduction, and External Rotation) Test
Passively flex, abduct, then gently externally rotate the leg. If pain is elicited during this movement, the location of the pain may help determine the location of the patient's pathology (e.g. hip joint, sacroiliac joint)



Schöber Test
Have patient stand erect with normal posture and locate the middle of the two posterior superior iliac spines
Mark 5 cm below this point and 10 cm above (total distance of 15 cm)
Re-measure the distance between the two marks with the patient flexed forward at the spine
This distance should increase by at least 5 cm in normal patients



Extra-Articular Manifestations of AS
6 As
Atlanto-axial subluxation
Anterior uveitis
Apical lung fibrosis
Aortic incompetence
Amyloidosis (kidneys)
Autoimmune bowel disease (ulcerative colitis)

Prognosis

- spontaneous remissions and relapses are common and can occur at any age
- function may be excellent despite spinal deformity
- favourable prognosis if female and age of onset >40 yr
- early onset with hip disease may lead to severe disability; may require arthroplasty

Enteropathic Arthritis

- see [Gastroenterology](#), *Inflammatory Bowel Disease*, G19
- MSK manifestations in the setting of either ulcerative colitis or Crohn's disease include peripheral arthritis (large joint, asymmetrical), spondylitis, and hypertrophic osteoarthropathy
- non-arthritic MSK manifestations can occur 2° to steroid treatment of bowel inflammation (arthralgia, myalgia, osteoporosis, AVN)
- NSAIDs should be used cautiously as they may exacerbate bowel disease

Table 28. Comparing Features of Spondylitis vs. Peripheral Arthritis in EA

Parameter	Spondylitis	Peripheral Arthritis
HLA-B27 Association	Yes	No
Gender	M>F	M=F
Onset Before IBD	Yes	No
Parallels IBD Course	No	Yes
Type of IBD	UC=CD	CD

Psoriatic Arthritis**Definition**

- arthritic inflammation associated with psoriasis

Etiology and Pathophysiology

- unclear but many genetic, immunologic, and some environmental factors involved (e.g. bacterial, viral, and trauma)

Epidemiology

- psoriasis affects 1% of population
- arthropathy in 15% of patients with psoriasis
- 15-20% of patients will develop joint disease before skin lesions appear

Signs and Symptoms

- **dermatologic**
 - well-demarcated erythematous plaques with silvery scale
 - nail involvement: pitting, transverse or longitudinal ridging, discolouration, subungual hyperkeratosis, onycholysis, and oil drops
- **musculoskeletal**
 - 5 general patterns
 - ◆ asymmetric oligoarthritis (most common – 70%)
 - ◆ arthritis of DIP joints with nail changes
 - ◆ destructive (mutilans) arthritis (5%)
 - ◆ symmetric polyarthritis (similar to RA)
 - ◆ sacroiliitis and spondylitis (usually older, male patients)
 - other findings: dactylitis, enthesopathy
- **ophthalmic**
 - conjunctivitis, iritis (anterior uveitis)
- **cardiac and respiratory** (late findings)
 - aortic insufficiency
 - apical lung fibrosis
- **neurologic**
 - cauda equina syndrome
- **radiologic**
 - floating syndesmophytes
 - pencil-in-cup appearance at IP joints
 - osteolysis, periostitis

Treatment

- treat skin lesions (e.g. steroid cream, salicylic and/or retinoic acid, tar, UV light)
- NSAIDs or IA steroids
- DMARDs, biologic therapies to minimize erosive disease (use early if peripheral joint involvement)



Both AS and EA feature symmetric sacroiliitis



Check "hidden" areas for psoriatic lesions (ears, hair line, umbilicus, gluteal cleft, nails)



Risks and Benefits of Tumour Necrosis Factor-alpha (TNF- α) Inhibitors in the Management of Psoriatic Arthritis (PsA): Systematic Review and Meta-analysis of Randomized Controlled Trials
J Rheumatol 2008;35:883-890
Study: Review of RCTs of adalimumab, etanercept, and infliximab used in patients with PsA.
Results: Six RCTs were included (n=982). All 3 TNF- α inhibitors were significantly more effective than placebo on the basis of Psoriatic Arthritis Response Criteria (PsARC) and American College of Rheumatology response criteria ACR20, ACR50, and ACR70 ratings. There were no significant differences between TNF- α inhibitors and placebo in the proportions of patients who withdrew for any reason (RR 0.48, 95% CI 0.20-1.18), or withdrawal due to adverse events (RR 2.14, 95% CI 0.73-6.27), serious adverse events (RR 0.98, 95% CI 0.55-1.77), or upper respiratory tract infections (RR 0.91, 95% CI 0.65-1.28). Pooled rates for injection site reactions were significantly higher for adalimumab and etanercept than for placebo (RR 2.48, 95% CI 1.16-5.29), but there was no significant difference in the proportion of patients experiencing infusion reactions with infliximab (RR 1.03, 95% CI 0.48-2.20) compared to placebo. Indirect analysis did not demonstrate any significant differences between the TNF- α inhibitors.
Conclusions: TNF- α inhibitors are effective treatments for PsA with no important added risks associated with their short-term use. There is still a need for long-term risk-benefit assessment of use of these drugs for the management of PsA.

Table 29. CASPAR Criteria for PsA*

Criterion	Description
1. Evidence of psoriasis	Current, past, or family history
2. Psoriatic nail dystrophy	Onycholysis, pitting, hyperkeratosis
3. Negative results for RF	
4. Dactylitis	Current or past history
5. Radiological evidence	Juxta articular bone formation on hand or foot x-rays

* To meet the CASPAR (Classification criteria for Psoriatic ARthritis) criteria, a patient must have inflammatory articular disease (joint, spine, or entheses) with ≥ 3 points from the above 5 categories
Arthritis Rheum 2006 Aug;54(8):2665-73. Classification criteria for PsA: development

Reactive Arthritis

Definition

- two meanings
 - reactive arthritis: a sterile arthritis following an infection (e.g. rheumatic fever, post-viral arthritis, etc.), not used frequently by rheumatologists
 - reactive arthritis (ReA): one of the seronegative spondyloarthropathies in which patients have a peripheral arthritis (>1 mo duration) accompanied by one or more extra-articular manifestations that appears shortly after certain infections of the GI or GU tracts



Clinical Triad of Reactive Arthritis

- Arthritis
- Conjunctivitis/uveitis
- Urethritis/cervicitis

Etiology

- onset following an infectious episode either involving the GI or GU tract
 - GI: *Shigella*, *Salmonella*, *Campylobacter*, *Yersinia* species
 - GU: *Chlamydia* (isolated in 16-44% of ReA cases), *Mycoplasma* species
- acute clinical course
 - 1-4 wk post-infection
 - lasts weeks to years
 - often recurring
 - spinal involvement persists

Epidemiology

- in HLA-B27 patients, axial $>$ peripheral involvement
- M $>$ F

Signs and Symptoms

- musculoskeletal**
 - peripheral arthritis, asymmetric pattern, spondylitis, Achilles tendinitis, plantar fasciitis, dactylitis
- ophthalmic**
 - iritis (anterior uveitis), conjunctivitis
- dermatologic**
 - keratoderma blennorrhagicum (hyperkeratotic skin lesions on palms and soles) and balanitis circinata (small, shallow, painless ulcers of glans penis and urethral meatus) are diagnostic
- gastrointestinal**
 - oral ulcers, diarrhea
- urethritis and cervicitis**
 - sterile pyuria; presence not related to site of initiating infection



"Can't see, can't pee, can't climb a tree"

Triad of conjunctivitis, urethritis, and arthritis is 99% specific (but 51% sensitive) for ReA

Investigations

- diagnosis is clinical plus laboratory
- blood work: normocytic, normochromic anemia, and leukocytosis
- sterile cultures
- serology: HLA-B27 positive

Treatment

- antibiotics for non-articular infections
- NSAIDs, physical therapy, exercise
- local therapy
 - joint protection
 - IA steroid injection
 - topical steroid for ocular involvement
- systemic therapy
 - corticosteroids, sulfasalazine, MTX (for peripheral joint involvement only)
 - TNF- α inhibitors for spinal inflammation

Prognosis

- self-limited, typically 3-5 mo, varies based on pathogen and patient's genetic background
- chronic in 15-20% of cases

Crystal-Induced Arthropathies

Table 30. Gout vs. Pseudogout

Parameter	Gout	Pseudogout
Gender	M>F	M=F
Age	Middle-aged males Post-menopausal females	Age >60 yr
Onset of Disease	Acute	Acute/insidious
Crystal Type	Monosodium urate Negative birefringence (yellow when parallel to compensator filter), needle-shaped	CPPD Positive birefringence (blue when parallel), rhomboid-shaped
Distribution	First MTP classically; also midfoot, ankle, knee, or polyarticular	Knee, wrist; monoarticular, or polyarticular if chronic
Radiology (note findings are non-specific)	Erosions	Chondrocalcinosis OA (knee, wrist, 2 nd and 3 rd MCP)
Treatment	Acute: NSAIDs, corticosteroids, colchicine Chronic: ± allopurinol, febuxostat	NSAIDs, corticosteroids

Gout

Definition

- derangement in purine metabolism resulting in hyperuricemia; monosodium urate crystal deposits in tissues (tophi) and synovium (microtophi)

Etiology and Pathogenesis

- sources of uric acid: diet and endogenous synthesis
 - hypoxanthine → xanthine → uric acid
 - both steps catalyzed by xanthine oxidase

Hyperuricemia

- primary or genetic
 - mostly due to idiopathic renal underexcretion (90%)
 - also idiopathic overproduction or abnormal enzyme production/function
- secondary
 - dietary excess (particularly high consumption of beer, seafood, and meat)
 - underexcretion (>90%): renal failure, drugs, systemic conditions
 - overproduction (<10%): increased nucleic acid turnover states (e.g. malignancy, post-chemotherapy)
- sudden changes (increasing or decreasing) in uric acid concentration are more important than absolute values
 - acute gout can occur with normal serum uric acid
 - changes in pH, temperature, or initiation of antihyperuricemics may precipitate an acute gouty attack
- common precipitants: alcohol, dietary excess, dehydration, drugs (e.g. thiazide and loop diuretics), trauma, illness, surgery, starting xanthine oxidase inhibitor therapy
- other associated conditions: HTN, obesity, DM, starvation

Epidemiology

- most common in males >45 yr
- extremely rare in premenopausal females

Signs and Symptoms

- single episode progressing to recurrent episodes of acute inflammatory arthritis
- acute gouty arthritis
 - severe pain, redness, joint swelling, usually involving lower extremities
 - joint mobility may be limited
 - attack will subside spontaneously within several days to weeks; may recur
- tophi
 - urate deposits on cartilage, tendons, bursae, soft tissues, and synovial membranes
 - common sites: first MTP, ear helix, olecranon bursae, tendon insertions (common in Achilles tendon)
- kidney
 - gouty nephropathy
 - uric acid calculi

Investigations

- joint aspirate: >90% of joint aspirates show crystals of monosodium urate (negatively birefringent, needle-shaped)
- x-rays may show tophi as soft tissue swelling, punched-out lesions, erosion with "over-hanging"

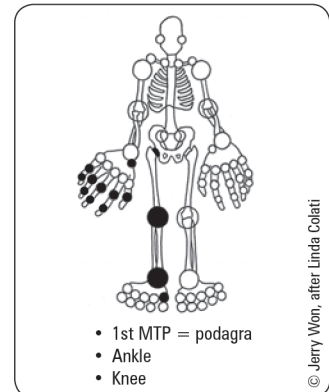


Figure 13. Common sites of involvement in gout (asymmetric joint involvement)



- An acute gout attack may mimic cellulitis; however, joint mobility is preserved in cellulitis
- Gout often affects more than one joint (i.e. ankle, midfoot, and MTPs)



Precipitants of Gout

Drugs are FACT

Furosemide
Aspirin®/Alcohol
Cytotoxic drugs
Thiazide diuretics

Foods are SALT

Seafood
Alcohol (beer and spirits)
Liver and kidney
Turkey (meat)



- The majority of people with hyperuricemia do not have gout
- Normal or low uric acid levels do not rule out gout



10 Recommendations on the Diagnosis and Management of Gout

Ann of Rheum Dis 2013;73:328-335

- Identification of monosodium urate crystals should be performed for a definitive diagnosis of gout.
- Gout/hyperuricemia should prompt investigations of renal function and CV risk factors.
- Acute gout should be treated with colchicine, NSAIDs, and/or glucocorticoids.
- Patients should be counselled about lifestyle.
- Allopurinol is first line for urate lowering therapy, with uricosurics as second line.
- Patients should be informed about the risk of acute gout flare with initiation of urate lowering therapy; colchicine prophylaxis should be considered.
- Allopurinol can be used in patients with mild/moderate renal impairment with slow titration and monitoring.
- Treatment goal is urate <0.36 mM and absence of attacks and resolution of tophi.
- Tophi should be treated medically by lowering serum urate to <0.3 mM. Surgery is only for select cases.
- Prophylactic pharmacological management of asymptomatic hyperuricemia is not recommended.

Treatment

- **acute gout**
 - NSAIDs: high dose, then taper as symptoms improve
 - corticosteroids: IA, oral, or intra-muscular (if renal, cardiovascular, or GI disease and/or if NSAIDs contraindicated or failed)
 - colchicine within first 12 h but effectiveness limited by narrow therapeutic range
 - allopurinol can worsen an acute attack (do not start during acute flare)
- **chronic gout**
 - conservative
 - ♦ avoid foods with high purine content (e.g. visceral meats, sardines, shellfish, beans, peas)
 - ♦ avoid drugs with hyperuricemic effects (e.g. pyrazinamide, ethambutol, thiazide, alcohol)
 - medical
 - ♦ antihyperuricemic drugs (allopurinol and febuxostat): decrease uric acid production by inhibiting xanthine oxidase
 - ♦ uricosuric drugs (probenecid, sulfinpyrazone): use if failure on or intolerant to allopurinol; do not use in renal failure
 - prophylaxis prior to starting antihyperuricemic drugs (colchicine/low-dose NSAID)
 - in renal disease secondary to hyperuricemia, use low-dose allopurinol and monitor Cr
- indications for treatment with antihyperuricemic medications include
 - recurrent attacks, tophi, bone erosions, urate kidney stones
 - perhaps in renal dysfunction with very high urate load (controversial)

Pseudogout (Calcium Pyrophosphate Dihydrate Disease)

Definition

- joint inflammation caused by calcium pyrophosphate crystals

Etiology and Pathophysiology

- acute inflammatory arthritis due to phagocytosis of IgG-coated CPPD crystals by neutrophils and subsequent release of inflammatory mediators within joint space
- more frequently polyarticular
- slower in onset in comparison to gout, lasts up to 3 wk but is self-limited

Risk Factors

- old age, advanced OA, neuropathic joints
- other associated conditions: hyperparathyroidism, hypothyroidism, hypomagnesemia, hypophosphatasia (low ALP), DM, hemochromatosis

Signs and Symptoms

- affects knees, wrists, MCPs, hips, shoulders, elbows, ankles, big toe
- multiple manifestations
 - asymptomatic crystal deposition (seen on radiograph only)
 - acute crystal arthritis (self-limited flares of acute inflammatory arthritis resembling gout)
 - pseudo-OA (progressive joint degeneration, sometimes with episodes of acute inflammatory arthritis)
 - pseudo-RA (symmetrical polyarticular pattern with morning stiffness and constitutional symptoms)
- acute may be triggered by dehydration, acute illness, surgery, trauma

Investigations

- must aspirate joint to rule out septic arthritis, gout
- CPPD crystals: present in 60% of patients, often only a few crystals, positive birefringence (blue) and rhomboid shaped
- x-rays show chondrocalcinosis in 75%: radiodensities in fibrocartilaginous structures (e.g. knee menisci) or linear radiodensities in hyaline articular cartilage

Treatment

- joint aspiration, rest, and protection
- NSAIDs: also used for maintenance therapy
- prophylactic colchicine PO (controversial)
- IA or oral steroids to relieve inflammation

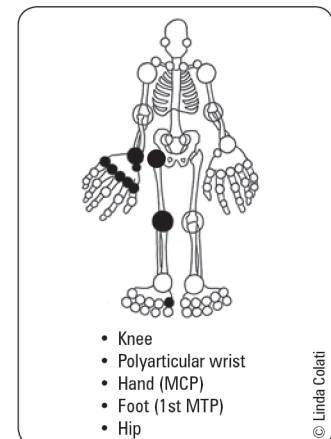


Figure 14. Common sites of involvement in CPPD

Non-Articular Rheumatism

Definition

- disorders that primarily affect soft tissues or periarticular structures
- includes bursitis, tendinitis, tenosynovitis, fibromyalgia, and PMR

Polymyalgia Rheumatica



Definition

- characterized by pain and stiffness of the proximal extremities (girdle area)
- closely related to GCA (15% of patients with PMR develop GCA)
- no muscle weakness

Table 31. PMR Classification Criteria Scoring Algorithm*

	Points without U/S (0-6)	Points with Abnormal U/S** (0-8)
Morning stiffness duration >45 min	2	2
Hip pain or limited ROM	1	1
Absence of RF or ACPA	2	2
Absence of other joint involvement	1	1
At least one shoulder with subdeltoid and/or biceps tenosynovitis and/or glenohumeral synovitis (either posterior or axillary) and at least one hip with synovitis and/or trochanteric bursitis on U/S	N/A	1
Both shoulders with subdeltoid bursitis, biceps tenosynovitis, or glenohumeral synovitis on U/S	N/A	1

*Required criteria: age \geq 50 yr, bilateral shoulder aching, and abnormal ESR/CRP

**A score of 4 or more is categorized as PMR in the algorithm without U/S and a score of 5 or more is categorized as PMR in the algorithm with U/S

**Optional U/S criteria

Ann Rheum Dis 2012;71:484-492

Epidemiology

- incidence 50 per 100,000 per year in those >50 yr
- age of onset typically >50 yr, F:M = 2:1

Signs and Symptoms

- constitutional symptoms prominent (fever, weight loss, malaise)
- pain and stiffness of symmetrical proximal muscles (neck, shoulder and hip girdles, thighs)
- gel phenomenon (stiffness after prolonged inactivity)
- physical exam reveals tender muscles, but no weakness or atrophy

Investigations

- blood work: often shows anemia, elevated platelets, elevated ESR and CRP, and normal CK; up to 5% of PMR reported with normal inflammatory markers

Treatment

- goal of therapy: symptom relief
- start with prednisone dose of 15-20 mg PO OD, reconsider diagnosis if no response within several days
- taper slowly over 2 yr period monitoring ESR and symptoms closely
- relapses should be diagnosed and treated on clinical basis; do not treat a rise in ESR as a relapse
- treat relapses aggressively (50% relapse rate)
- monitor for steroid side effects, glucocorticoid-induced osteoporosis prevention, and follow for symptoms of GCA



Most patients are treated for up to 2 yr

Fibromyalgia

Definition

- chronic (>3 mo), widespread (axial, left- and right-sided, upper and lower segment), non-articular pain with characteristic tender points

Diagnosis

Table 32. 2010 ACR Preliminary Diagnostic Criteria for Fibromyalgia

Criteria	Comments
<p>Widespread Pain Index = number of areas in which the patient had pain over the last week (max score = 19):</p> <p>L and R: shoulder girdle, upper arm, lower arm, hip, upper leg, lower leg, jaw</p> <p>One Area: chest, abdomen, upper back, lower back, neck</p> <p>Symptom Severity Score = sum of:</p> <ol style="list-style-type: none"> severity of fatigue waking unrefreshed cognitive symptoms over the past week extent of somatic symptoms (IBS, H/A, abdominal pain/cramps, dry mouth, fever, hives, ringing in ears, vomiting, heartburn, dry eyes, SOB, loss of appetite, rash, hair loss, easy bruising, etc.) <p>all (a-d) rated on 0-3 scale: 0 = no problem, 1 = mild, 2 = moderate, 3 = severe</p>	<p>A patient satisfies diagnostic criteria for fibromyalgia if the following 3 conditions are met:</p> <ol style="list-style-type: none"> Widespread Pain Index (WPI) ≥ 7 and Symptom Severity (SS) scale score ≥ 5 or WPI 3-6 and SS scale score ≥ 9 Symptoms have been present at a similar level for at least 3 mo The patient does not have a disorder that would otherwise explain the pain

Arthritis Care and Research 2010;62(5):600-610

Epidemiology

- F:M = 3:1
- primarily ages 25-45 yr, some adolescents
- prevalence of 2-5% in general population
- overlaps with chronic fatigue syndrome and myofascial pain syndrome
- strong association with psychiatric illness

Signs and Symptoms

- widespread aching, stiffness
- easy fatigability
- sleep disturbance: non-restorative sleep, difficulty falling asleep, and frequent waking
- symptoms aggravated by physical activity, poor sleep, emotional stress
- patient feels that joints are diffusely swollen although joint examination is normal
- neurologic symptoms of hyperalgesia, paresthesias
- associated with irritable bowel or bladder syndrome, migraines, tension H/As, restless leg syndrome, obesity, depression, and anxiety
- physical exam should reveal only tenderness with palpation of soft tissues, with no specificity for trigger/tender points

Investigations

- blood work: includes TSH and ESR; all typically normal unless unrelated, underlying illness present
- serology: do not order ANA or RF unless there is clinical suspicion for a connective tissue disease
- laboratory sleep assessment

Differential Diagnosis

- diagnosis of exclusion
- rule out other disorders by history and physical exam (RA, SLE, PMR, myositis, hypothyroidism, hyperparathyroidism, neuropathies)

Treatment

- non-pharmacological therapy**
 - education
 - exercise program (walking, aquatic exercises), physical therapy (good posture, stretching, muscle strengthening, massage)
 - stress reduction, CBT
 - no evidence for alternative medicine such as biofeedback, meditation, acupuncture



A 14 Week, RCT of Pregabalin in Patients with Fibromyalgia

J Pain 2008;9:792-880

Study: Multicentre RCT. 750 patients with fibromyalgia with pain score of <40 mm on the visual analog scale (VAS) were assigned to placebo or pregabalin (300 mg, 450 mg, or 600 mg) daily for 12 wk.

Primary Outcome: Change in the mean pain score derived from the subject's daily pain diary as measured at the patient's baseline to the end point of the study.

Results: Patients treated with 300, 450 and 600 mg/d pregabalin showed a statistically significant improvement in the end point mean pain score compared with placebo-treated subjects. Discontinuations due to adverse events were 12%, 16%, 22%, and 26% in placebo, 300 mg/d, 450 mg/d, and 600 mg/d respectively. The 450 and 600 mg/d groups were significantly different from placebo ($p=0.0001$).

Conclusions: Pregabalin at 300 mg/d, 450 mg/d, and 600 mg/d showed statistically significant response rates as compared to placebo although discontinuation rates for the 450 mg/d and 600 mg/d regimens were significantly higher as compared to placebo.



Exercise for Treating Fibromyalgia Syndrome

Cochrane DB Syst Rev 2008;CD003786

Study: Systematic review of exercise training including cardiorespiratory endurance, muscle strengthening, and flexibility for global well-being and physical function in patients with fibromyalgia.

Result: 34 studies were included ($n=2,276$). Aerobic-only exercises improve global well-being, physical function, and possibly pain and tender points. There was insufficient data to evaluate the effect of strength and flexibility on the primary outcomes.

Conclusions: Moderate aerobic cardiorespiratory exercise improves function and well-being in patients with fibromyalgia. Benefits from muscle strengthening and flexibility require additional research to delineate benefits.

- **pharmacological therapy**
 - low dose tricyclic antidepressant (e.g. amitriptyline)
 - ♦ for sleep restoration
 - ♦ select those with lower anticholinergic side effects
 - SNRI: duloxetine, milnacipran
 - anticonvulsant: pregabalin, gabapentin
 - analgesics may be beneficial for pain that interferes with sleep (NSAIDs, not narcotics)

Prognosis

- variable; usually chronic, unless diagnosed and treated early

Adult Onset Still's Disease

Definition

- systemic inflammatory condition (ANA and RF negative) with fevers and characteristic rash, numerous systemic symptoms, and may have severe arthritis

Etiology and Pathophysiology

- idiopathic; infectious triggers likely – various viruses and bacteria have been implicated
- stress increases risk

Epidemiology

- F>M; age of onset typically 16-40, approximately 1 per 100,000

Signs and Symptoms

- classic triad of symptoms
 - high-spiking fevers (95.7% of patients, typically T = 39°C, <4 h duration, quotidian pattern)
 - characteristic “salmon rash” (~72% of patients, on proximal limbs + trunk)
 - arthralgia/arthritis (64-100%)
 - ♦ arthritis is symmetric, typically affects large joints, i.e. wrists, knees and ankles, may involve PIP and DIPs, elbow, MTPs
- sore throat, myalgias and serositis may also occur
- liver abnormalities ± hepatomegaly (50-75% patients)
- splenomegaly (44%)

Classification

- numerous classification systems proposed

Table 33. Yamaguchi's Criteria for Classification of Adult Still's Disease

Major Criteria	Minor Criteria
T > 39°C, intermittent, >1 wk Arthralgias/arthritis ≥2 wks Typical rash WBC > 10,000 (>80% granulocytes)	Sore throat Lymphadenopathy Hepatomegaly or splenomegaly Abnormal transaminases Negative ANA and RF

Need 5 criteria for diagnosis, at least 2 major. Exclusion criteria: infection, malignancy, rheumatic disease

J Rheumatol 1992;19:424-30

Investigations

- ANA and RF negative
- markedly elevated ESR, CRP, ferritin (typically >1000 ng/mL)
 - total ferritin >5x ULN = 80% sensitive, 41% specific
- anemia, thrombocytosis, leukocytosis may occur
- transaminases, LDH may be elevated

Treatment

- biologics (anti-IL-1 and anti-IL-6 agents)
- begin management with low-dose glucocorticoids ± MTX



Triad of Still's Disease

FAR
Fever
Arthralgias/Arthritis
Rash

Common Medications

Table 34. Common Medications for Osteoarthritis

Class	Generic Drug Name	Trade Name	Dosing (PO)	Indications	Contraindications	Adverse Effects
Analgesic	acetaminophen	Tylenol®	500 mg tid q4h (4 g daily max)	1 st line		Hepatotoxicity Overdose Potentiates warfarin
NSAIDs	ECASA ibuprofen diclofenac diclofenac/misoprostol naproxen meloxicam	Entrophen® Advil®, Motrin® Voltaren® Arthrotec® Naprosyn®, Aleve® Mobicox®	325-975 mg qid 200-600 mg tid 25-50 mg tid 50-75/200 mg tid 125-500 mg bid 7.5-15 mg OD	2 nd line	GI bleed Renal impairment Allergy to ASA, NSAIDs Pregnancy (T3)	Nausea, tinnitus, vertigo, rash, dyspepsia, GI bleed, PUD, hepatitis, renal failure, HTN, nephrotic syndrome
COX-2 INHIBITORS						
	celecoxib	Celebrex®	200 mg OD	High risk for GI bleed: age >65 Hx of GI bleed, PUD	Renal impairment Sulfa allergy (celecoxib) Cardiovascular disease	Delayed ulcer healing Renal/hepatic impairment Rash
Other Treatments		Comments				
Combination analgesics (acetaminophen + codeine, acetaminophen + NSAIDs)		Enhanced short-term effect compared to acetaminophen alone More adverse effects: sedation, constipation, nausea, GI upset				
IA corticosteroid injection		Short-term (weeks-months) decrease in pain and improvement in function Used for management of an IA inflammatory process when infection has been ruled out				
IA hyaluronic acid q6mo		Used for mild-moderate OA of the knees, however little supporting evidence, and not considered to be effective Precaution with chicken/egg allergy				
Topical NSAIDs		25% wt/wt topical diclofenac (Pennsaid®) May use for patients who fail acetaminophen treatment and who wish to avoid systemic therapy				
Capsaicin cream		Mild decrease in pain				
Glucosamine sulfate ± chondroitin		Limited clinical studies No regulation by Health Canada				

Table 35. Disease Modifying Anti-Rheumatic Drugs (DMARDs)

Generic Drug Name	Trade Name	Dosing	Contraindications	Adverse Effects
COMMONLY USED				
hydroxychloroquine \$	Plaqueni®	400 mg PO OD initially 200-400 mg PO OD maintenance (6.5 mg/kg ideal body weight per day)	Retinal disease, G6PD deficiency	GI symptoms, skin rash, macular damage, neuromyopathy Requires regular ophthalmological screening to monitor for retinopathy
sulfasalazine \$	Salazopyrim® Azulfidine® (US)	1000 mg PO bid-tid	Sulfa/ASA allergy, kidney disease, G6PD deficiency	GI symptoms, rash, H/A, leukopenia
methotrexate \$	Rheumatrex® Folex/Mexate®	7.5-25 mg PO/IM/SC qweekly	Bone marrow suppression, liver disease, significant lung disease, immunodeficiency, pregnancy, EtOH abuse	Oral ulcers, GI symptoms, cirrhosis, myelosuppression, pneumonitis, tubular necrosis
leflunomide \$\$	Arava®	10-20 mg PO OD	Liver disease	Alopecia, GI symptoms, liver dysfunction, pulmonary infiltrates
NOT COMMONLY USED				
cyclosporine \$\$	Neoral®	2.5-3 mg/kg/d divided and given in 2 doses PO	Kidney/liver disease, infection, HTN	HTN, decreased renal function, hair growth, tremors, bleeding
gold (injectable) \$	Solganal® Myocrysine®	50 mg IM q1wk after gradual introduction	IBD, kidney/liver disease	Rash, mouth soreness/ulcers, proteinuria, marrow suppression
azathioprine \$	Imuran®	2/5 mg/kg/d PO once daily	Kidney/liver disease TPMT deficiency	Rash, pancytopenia (especially ↓ WBC, ↑ AST, ALT), biliary stasis, vomiting, diarrhea
cyclophosphamide \$	Cytosan®	1 g/m ² /mo IV as per protocol	Kidney/liver disease	Cardiotoxicity, GI symptoms, hemorrhagic cystitis, nephrotoxicity, bone marrow suppression, sterility

Table 35. Disease Modifying Anti-Rheumatic Drugs (DMARDs) (continued)

Generic Drug Name	Trade Name	Dosing	Mechanism of Action
NEWER DMARDs (Biologics)			
etanercept \$\$\$	Enbrel®	25 mg biweekly or 50 mg weekly SC	Fusion protein of TNF receptor and Fc portion of IgG
infliximab \$\$\$	Remicade®	3-5 mg/kg IV q8wk	Chimeric mouse/human monoclonal anti-TNF
adalimumab \$\$\$	Humira®	40 mg SC q2wk	Monoclonal anti-TNF
abatacept \$\$\$	Orencia®	IV infusion	Costimulation modulator of T-cell activation
rituximab \$\$\$	Rituxan®	2 IV infusions, 2 wk apart	Causes B-cell depletion, binds to CD20
certolizumab \$\$\$	Cimzia®	400 mg SC q2wk x3 then 200 mg SC q4wk	PEGylated monoclonal anti-TNF
golimumab \$\$\$	Simponi®	50 mg SC q mo	Monoclonal anti-TNF
tocilizumab \$\$\$	Actemra®	4-8 mg/kg IV q4wk	Interleukin-6 receptor antagonist

**Risks of Biologics**

- Reactivation of TB or hepatitis B. Patients require negative TB skin test, chest x-ray and negative hepatitis B virus serology prior to starting any of these medications
- Increased risk of serious infections
- Worsening heart failure

Landmark Rheumatology Trials

Trial	Reference	Results
RHEUMATOID ARTHRITIS		
ATTEST	<i>Ann Rheum Dis</i> 2008; 67:1096-103	Abatacept and infliximab have similar efficacy in RA patients who have failed MTX
ATTRACT	<i>Lancet</i> 1999; 354:1932-9	Infliximab and MTX combined are more effective than MTX alone for patients with active RA
CIMESTRA	<i>Arthritis Rheum</i> 2006; 54:1401-9	Combination of MTX and sulfasalazine is superior to either alone
COMET	<i>Lancet</i> 2008; 372:375-82	Etanercept add-on therapy increases rates of remission in early RA
ERA	<i>NEJM</i> 2000; 343:1586-93	Etanercept more rapidly decreases symptoms in early RA compared to MTX
European Leflunomide Study Group	<i>Lancet</i> 1999; 353:259-66	Leflunomide is equal in efficacy to sulphasalazine
FIN-RACo	<i>Lancet</i> 1999; 353:1568-73	Combination therapy with DMARDs improves remission rates in early RA
Infliximab and MTX	<i>NEJM</i> 2000; 343:1594-602	Infliximab combined with MTX reduces joint damage in RA
Leflunomide Rheumatoid Arthritis Investigators Group	<i>Arch Intern Med</i> 1999; 159:2542-50	Leflunomide is equivalent to MTX therapy and superior to placebo
PREMIER	<i>Arthritis Rheum</i> 2006; 54:26-37	Combination therapy with adalimumab and MTX is superior to either alone in patients with early RA
Swefot	<i>Lancet</i> 2009; 374:459-66	Anti-TNF agents are more effective second-line therapy than DMARDs in patients who fail MTX
OSTEOARTHRITIS		
GAIT	<i>NEJM</i> 2006; 354:795-808	Glucosamine, chondroitin, and the combination of both are no more effective than placebo in treatment of knee OA
Hyaluronan	<i>Ann Rheum Dis</i> 2010; 69:1097-102	Hyaluronan injections do not improve disease activity in patients with moderate-severe knee OA
SLE		
Belimumab	<i>Lancet</i> 2011; 377:721-31	Treatment with belimumab reduces the incidence of BILAG A and B flares in patients with SLE compared to placebo
BILAG open-RCT	<i>Rheumatology</i> 2010; 49:723-32	Low dose cyclosporine and azathioprine are equivalent in efficacy as maintenance therapy for SLE
Mycophenylate mofetil or intravenous cyclophosphamide	<i>NEJM</i> 2005; 353:2219-28	Mycophenylate mofetil is more efficacious than cyclophosphamide in inducing remission of SLE nephritis
CONNECTIVE TISSUE DISEASES		
Azathioprine or MTX maintenance for ANCA-associated vasculitis	<i>NEJM</i> 2008; 359:2790-803	MTX and azathioprine are equally safe and effective as maintenance agents in ANCA vasculitis

Trial	Reference	Results
Cyclophosphamide in scleroderma lung disease	<i>NEJM</i> 2006; 354:2655-66	Cyclophosphamide therapy leads to transient improvements in lung function, skin scores, and overall health in patients with scleroderma
Etanercept plus standard therapy for granulomatosis with polyangiitis	<i>NEJM</i> 2005; 352:351-61	Etanercept is not effective in inducing remission in patients with ANCA vasculitis
Mycophenylate mofetil vs. azathioprine for maintenance in ANCA-associated vasculitis	<i>JAMA</i> 2010; 304:2381-8	Mycophenylate mofetil is less effective than azathioprine for maintaining disease in ANCA-associated vasculitis
Rituximab versus cyclophosphamide for ANCA-associated vasculitis	<i>NEJM</i> 2010; 363:221-32	Rituximab is not inferior to cyclophosphamide for induction of remission in ANCA vasculitis
GOUT		
Febuxostat vs. allopurinol	<i>NEJM</i> 2005; 353:2450-61	Febuxostat is more effective than allopurinol at lowering serum urate, and has similar effectiveness on flare reduction
ANKYLOSING SPONDYLITIS		
Adalimumab	<i>Arthritis Rheum</i> 2006; 54:2136-46	Adalimumab induced partial remission in 22% of AS patients
ASSERT (rituximab)	<i>Arthritis Rheum</i> 2005; 52:582-91	Sixty percent of patients treated with rituximab had a clinical response to the medication
ATLAS (adalimumab)	<i>J Rheumatol</i> 2008; 35:1346-53	Compared to placebo, adalimumab significantly reduces pain and fatigue in AS patients
Infliximab in AS	<i>Lancet</i> 2002; 359:1187-93	Infliximab induces regression of symptoms in 50% of patients and is superior to placebo
SPINE (etanercept)	<i>Ann Rheum Dis</i> 2011; 70:799-804	Etanercept has short-term efficacy for patients with advanced AS and reduces disease severity
Sulfasalazine	<i>Arthritis Rheum</i> 1995; 38:618-27	Sulfasalazine is superior to placebo in treatment of patients with seronegative spondyloarthropathy

References

- ACR. Guidelines for the medical management of osteoarthritis of the hip. November 1995.
- ACR. Guidelines for the medical management of osteoarthritis of the knee. November 1995.
- ACR. Guidelines for referral and management of systemic lupus erythematosus in adults. September 1999.
- ACR Subcommittee on Rheumatoid Arthritis Guidelines, 2002. Guidelines for the management of rheumatoid arthritis, 2002 Update.
- Aletaha D, Neogi T, Silman AJ, et al. 2010 rheumatoid arthritis classification criteria. *Arthritis Rheum* 2010;62:2569-2581.
- Arnett FC, Edworthy SM, Bloch DA, et al. The American Rheumatism Association 1987 revised criteria for the classification of rheumatoid arthritis. *Arthritis Rheum* 1988;31:315-324.
- American College of Rheumatology Subcommittee on Rheumatoid Arthritis Guidelines. Guidelines for the management of rheumatoid arthritis: 2002 Update. *Arthritis Rheum* 2002;46:328-346.
- Bathon JM, Martin RW, Fleischmann RM, et al. A comparison of etanercept and methotrexate in patients with early rheumatoid arthritis. *NEJM* 2000;343:1586-1593.
- Bohan A, Peter JB. Polyomyositis and dermatomyositis (second of two parts). *NEJM* 1975;292:403-407.
- Bombardier C, Laine L, Reicin A, et al. Comparison of upper gastrointestinal toxicity of rofecoxib and naproxen in patients with rheumatoid arthritis. The VIGOR Study Group. *NEJM* 2000;343:1520-1528.
- Brady OH, Masri BA, Garbuz DS, et al. Joint replacement of the hip and knee – when to refer and what to expect. *CMAJ* 2000;163:1285-1291.
- Brater DC, Harris C, Redfern JS, et al. Renal effects of COX-2-selective inhibitors. *Amer J Nephrol* 2001;21:1-15.
- Bykrek VP, Akhavan P, Hazlewood GS. Canadian rheumatology association recommendations for pharmacological management of rheumatoid arthritis with traditional and biologic disease-modifying antirheumatic drugs. *J Rheumatol* 2011;39:1559-1582.
- Cibere J. Acute monoarthritis. *CMAJ* 2000;162:1577-1583.
- Clark BM. Physical and occupational therapy in the management of arthritis. *CMAJ* 2000;163:999-1005.
- Ensworth S. Is it arthritis? *CMAJ* 2000;162:1011-1016.
- Healey LA. Long-term follow-up of polymyalgia rheumatica: evidence for synovitis. *Semin Arthritis Rheum* 1984;13:322-328.
- Hochberg MC. Updating the American College of Rheumatology revised criteria for the classification of systemic lupus erythematosus [letter]. *Arthritis Rheum* 1997;40:1725.
- Hunder GG, Bloch DA, Michel BA, et al. The American College of Rheumatology 1990 criteria for the classification of giant cell arteritis. *Arthritis Rheum* 1990;33:1122-1128.
- Huang SHK. Basics of therapy. *CMAJ* 2000;163:417-423.
- Klippel JH, Weyand CM, Wortmann RL. *Primer on Rheumatic Diseases*, 11th ed. Arthritis Foundation, 1997.
- Klinkhoff A. Diagnosis and management of inflammatory polyarthritis. *CMAJ* 2000;162:1833-1838.
- Kremer JM. Rational use of new and existing disease-modifying agents in rheumatoid arthritis. *Ann Intern Med* 2001;134:695-706.
- Lacaille D. Advanced therapy. *CMAJ* 2000;163:721-728.
- Leavitt RY, Fauci AS, Bloch DA, et al. The American College of Rheumatology 1990 criteria for the classification of Wegener's granulomatosis. *Arthritis Rheum* 1990;33:1101-1017.
- Lightfoot RW Jr, Michel BA, Bloch DA, et al. The American College of Rheumatology 1990 criteria for the classification of polyarteritis nodosa. *Arthritis Rheum* 1990;33:1088-1093.
- McAlindon TE, Bannuru RR, Sullivan MC, et al. OARSI guidelines for the non-surgical management of knee osteoarthritis. *Osteoarthr Cartilage* 2014;22:363-388.
- Miyakis S, Lockshin MD, Atsumi T, et al. International consensus statement on an update of the classification criteria for definite antiphospholipid syndrome (APS). *J Thromb Haemost* 2006;4:295-306.
- Purtick MPE. Evaluation of the patient with pain all over. *CMAJ* 2001;164:223-227.
- Reid G, Esdaile JM. Getting the most out of radiology. *CMAJ* 2000;162:1318-1325.
- Shojania K. What laboratory tests are needed? *CMAJ* 2000;162:1157-1163.
- Sivera F, Andres M, Carmona L, et al. Recommendation: Multinational evidence-based recommendations for the diagnosis and management of gout: integrating systematic literature review and expert opinion of a broad panel of rheumatologists in the 3e initiative. *Ann of Rheum Dis* 2013;73:328-335.
- Smetana GW, Shmerling RH. Does this patient have temporal arteritis? *JAMA* 2002;287:92-101.
- Subcommittee for Scleroderma Criteria of the American Rheumatism Association Diagnostic and Therapeutic Criteria Committee. Preliminary criteria for the classification of systemic sclerosis (scleroderma). *Arthritis Rheum* 1980;23:581-590.
- Taunton JE, Wilkinson M. Diagnosis and management of anterior knee pain. *CMAJ* 2001;164:1595-1601.
- Tsang I. Pain in the neck. *CMAJ* 2001;164:1182-1187.
- van der Linden S, Valkenburg HA, Cats A. Evaluation of diagnostic criteria for ankylosing spondylitis. A proposal for modification of the New York criteria. *Arthritis Rheum* 1984;27:361.
- Vitali C, Bombardieri S, Jonsson R, et al. Classification criteria for Sjögren's syndrome: a revised version of the European criteria proposed by the American-European Consensus Group. *Ann Rheum Dis* 2002;61:554-558.
- Wade JP. Osteoporosis. *CMAJ* 2001;165:45-50.
- Wing PC. Minimizing disability in patients with low-back pain. *CMAJ* 2001;164:1459-1468.
- Wolfe F, Smythe HA, Yunus MB, et al. The American College of Rheumatology 1990 criteria for the classification of fibromyalgia: report of the multicenter criteria committee. *Arthritis Rheum* 1990;33:160-172.
- Wolfe F, Clauw DJ, Fitzcharles MA, et al. The American College of Rheumatology preliminary diagnostic criteria for fibromyalgia and measurement of symptom severity. *Arthritis Care and Research* 2010;62:600-610.